

BLOCK DIAGRAM

DEVICE CONNECTIONS *

COUNT (\bar{A}) - CMOS, Schmidt Trigger; used as count or count control input, depending on the mode of operation selected. It's generally used as a count input. See Modes of Operation for more details.

COUNT (\bar{B}) - CMOS, Schmidt Trigger; used as count or count control input, depending on the mode of operation selected. It's generally used as a count control input. See Modes of Operation for more details.

RESET (\bar{R}) - CMOS, Schmidt Trigger; counter is reset and held to zero when this pin is at a low level.

Note: Counter should always be RESET to zero whenever power is first applied to the unit.

INHIBIT (\bar{I}) - CMOS, Schmidt Trigger; all counting for all modes is inhibited when this input is at a low level. This input is asynchronous with inputs "A" and "B".

LATCH (\bar{L}) - CMOS, Schmidt Trigger; data on the display is latched when this input is at a high level. This input has no effect on the counting operations of the unit and is asynchronous with inputs "A" and "B".

LZB1, LZB2, LZB3 - CMOS, level sensitive; these inputs are used for leading zero blanking selection. See Decimal Point and Leading Zero Blanking Selection for more details.

MS1, MS2, MS3, MS4 - CMOS, level sensitive; these inputs are used for Mode Selection. These modes are: Bi-Directional Counting and Quadrature Counting. See Modes of Operation for more details.

DP1, DP2, DP3 - LCD inputs which must be connected to either BP or \bar{BP} to Turn Decimal Points "OFF" or "ON". See Decimal Point and Leading Zero Blanking Selection for more details.

BP, \bar{BP} - CMOS outputs for LCD. Used to turn decimal points "OFF" or "ON". See Decimal Point and Leading Zero Blanking Selection for more details.

V_{DD} - 2.5 to 6VDC Supply.

V_{SS} - Common for DC Supply and Inputs.

* All unused inputs must be tied to V_{SS} or V_{DD}, whichever is appropriate.

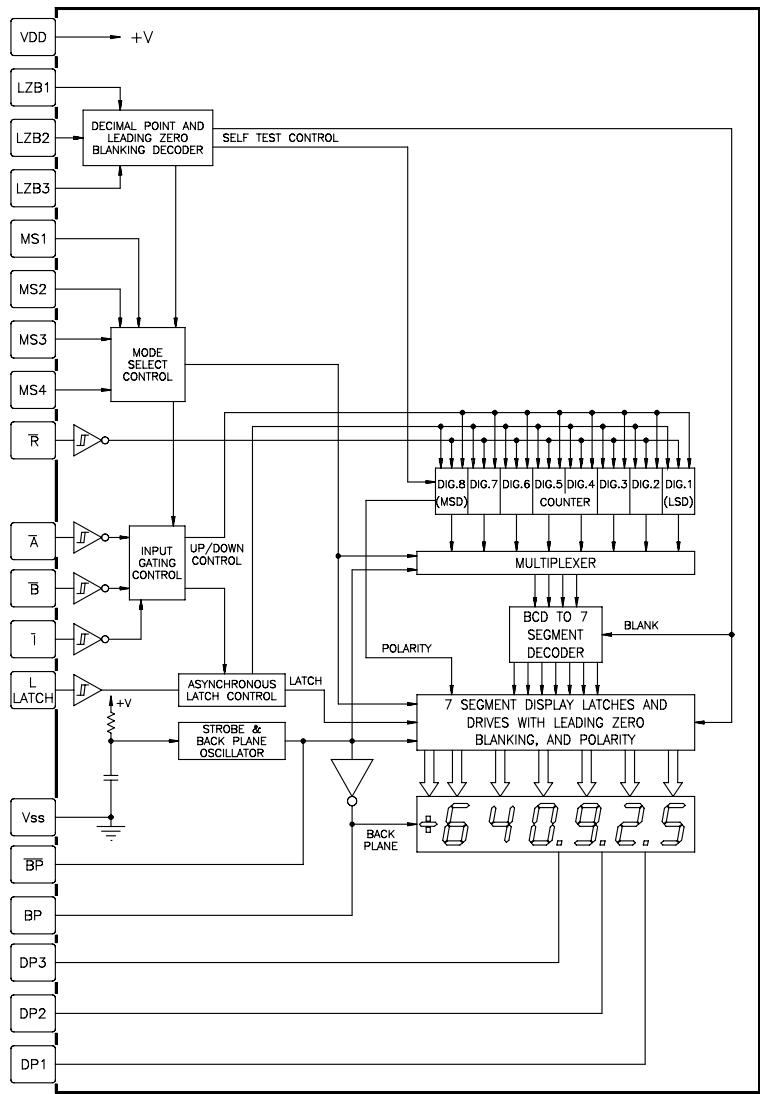

CAUTION

This device contains CMOS circuitry which requires special anti-static handling to the same degree required by standard CMOS integrated circuits. Units should be stored in the conductive packaging used to ship the devices. Containers should be opened and units handled only on a conductive table top by personnel wearing wrist-strap grounding equipment. These devices have the same protection circuits as standard CMOS devices to prevent damage to inputs due to nominal over-voltage.

MAXIMUM RATINGS (VOLTAGE REF. TO V_{SS})

RATING	SYMBOL	VALUE	UNIT
DC Supply Voltage	V _{DD}	-0.5 to +6.5	VDC
Input Voltage, All Inputs	V _I	-0.5 to (V _{DD} +0.5)	VDC
Operating Temperature	T _A	-35 to +85	°C
Storage Temperature	T _{STG}	-35 to +85	°C

ELECTRICAL CHARACTERISTICS V_{DD} = 5 V ±10% UNLESS OTHERWISE SPECIFIED

SYMBOL	PARAMETER	MIN.	TYP.	MAX.	UNIT	TEST CONDITION
V _{DD}	Supply Voltage	2.5		6.0	VDC	All Modes
I _{DD}	Supply Current		15	22	µA	f _c = 10 KHz
I _{DDQ}	Quiescent Current		6	12	µA	Not Counting
V _{IH}	Input High Voltage	3.9	3.0		VDC	
V _{IL}	Input Low Voltage		0.9	0.5	VDC	
I _{IL}	Input Leakage Current		0.01	0.1	µA	V _{SS} ≤ V _{IN} ≤ V _{DD}
f _c	Count Frequency (50% Duty Cycle)	500 250 200 100			KHz KHz KHz KHz	X1, ÷ 10 & 100 Bi-directional Modes X2, ÷ 5 & 50 Bi-directional Modes X1, X2, ÷ 10, 100, 5, & 50 Quadrature Mode X4, ÷ 2.5 & 25 Quadrature Mode
T _{RST}	Reset Pulse Width	10			µS	

MODES OF OPERATION

BI-DIRECTIONAL COUNTING MODES

For Bi-Directional counting, input “ \overline{A} ” serves as the count input, while input “ \overline{B} ” serves as the direction control input. In the Times 1 Mode when “ \overline{B} ” is at a low level, a negative going transition at “ \overline{A} ” will cause the counter to count in the positive direction. When “ \overline{B} ” is at a high level, a negative going transition at “ \overline{A} ” will cause the counter to count in the negative direction. Table 1 illustrates the level settings of the Mode Select Inputs for the various modes of Bi-Directional counting. The Times 2 Mode works like Times 1 Mode except the counter increments on both the positive and negative going transitions at “ \overline{A} ”. There are also two Divide-By Modes which prescale the display by 10 or by 100. This results in the capability of displaying the 7th and 8th digit of the internal counter. (Along with Times 2, this gives an equivalent $\div 5$ and $\div 50$ display.)

TABLE 1

MODE	MS4	MS3	MS2	MS1
Times 1	0	0	0	0
Times 2	0	1	1	0
(x2, $\div 10$) Divide by 5*	0	0	1	0
(x1, $\div 10$) Divide by 10	0	1	0	1
(x2, $\div 100$) Divide by 50*	0	0	1	1
(x1, $\div 100$) Divide by 100	0	1	0	0
* These factors include both a resolution multiplier and a decade prescaler.				
1 = V_{DD} = High Level 0 = V_{SS} = Low Level				

QUADRATURE COUNTING MODES

For Quadrature Times 1 counting, input “ A ” serves as the count input while input “ \overline{B} ” serves as the quadrature input. (Input “ \overline{B} ” is a pulse train shifted 90° away from “ A ”.) The counter will count in a positive going direction when “ A ” is a negative going signal and “ \overline{B} ” is low. The counter will count in a negative going direction when “ A ” is a positive going signal and “ \overline{B} ” is low. All transitions on “ A ” are ignored when “ \overline{B} ” is high. These logic rules provide the basis for anti-jitter operation which will prevent false counts from occurring, due to back-lash, vibration, chatter, etc.

Table 2 illustrates the level settings of the Mode Select Inputs for the various modes of Quadrature counting. The Times 2 Quadrature Mode works the same as Times 1 when “ \overline{B} ” is low. But when “ \overline{B} ” is high, counts are no longer ignored at “ A ”. Instead, the logic rules for “ A ” are complemented, allowing both edges of “ A ” to be counted. This gives an effective doubling of display count but more importantly, doubles the resolution of the input. The Times 4 Mode extends this even further. Both “ A ” and “ \overline{B} ” serve as count or quadrature input. In one instance, “ A ” will be the count input and “ \overline{B} ” will be the quadrature input. In another instance, “ \overline{B} ” will be the count input and “ A ” will be the quadrature input. This will result in counts and resolution four (4) times greater than in the Times 1 Mode. For counting rates on these modes, refer to the specification sheet (X2, X4, $\div 10$, $\div 100$ give an equivalent divide-by 2.5, 5, 25, and 50).

TABLE 2

MODE	MS4	MS3	MS2	MS1
Times 1	0	1	1	1
Times 2	1	0	0	0
Times 4	1	0	0	1
(x4, $\div 10$) Divide by 2.5*	1	1	0	1
(x2, $\div 10$) Divide by 5*	1	0	1	0
(x1, $\div 10$) Divide by 10	1	1	1	0
(x4, $\div 100$) Divide by 25*	1	1	0	0
(x2, $\div 100$) Divide by 50*	1	0	1	1
(x1, $\div 100$) Divide by 100	1	1	1	1
* These factors include both a resolution multiplier and a decade prescaler.				
1 = V_{DD} = High Level 0 = V_{SS} = Low Level				

DECIMAL POINT AND LEADING ZERO BLANKING SELECTION

The SUB CUB D has three decimal point inputs to the LCD (DP1, DP2, and DP3), and two signal outputs from the counter chip. A decimal point is turned OFF when the LCD input is connected to the BP signal output; or turned ON when it is connected to the \overline{BP} output. Refer to Table 3.

The number of leading zeros present on the SUB CUB D display is determined by the settings of the LZB inputs. Table 4 illustrates the level settings required for a display of a single 0, to one with no leading zero blanking. Note that the decimal point position is set independently of the selection of leading zeros.

TABLE 3

	D.P.3	D.P.2	D.P.1
No DP	BP	BP	BP
1st DP	BP	BP	\overline{BP}
2nd DP	BP	\overline{BP}	BP
3rd DP	\overline{BP}	BP	BP

TABLE 4

MODES	LZB3	LZB2	LZB1
Test Mode*	0	0	0
0	0	0	1
00	0	1	0
000	0	1	1
0000	1	0	0
00000	1	0	1
000000	1	1	0

* Test Mode is intended for factory use only.

TYPICAL APPLICATIONS

QUADRATURE TIMES FOUR

In this application, it is necessary to keep track of the exact position of a work table. The work table can be moved left or right and is driven by a lead screw. Because the two requirements of critical positioning and direction reversal must be satisfied, the Quadrature Mode of the SUB CUB D is selected. An RRGB with 10 PPR, quadrature, current sinking output is coupled to the screw shaft. The screw shaft moves the table one inch for every 25 revolutions which yields 250 pulses/inch of travel. But in this application, a higher degree of resolution is needed without using a higher resolution sensor. Therefore, the Times Four Quadrature Mode is selected which results in a reading of 1000 counts per inch of travel or 0.001" increments of resolution.

The drawing illustrates connections for the inputs and mode select lines, including buffering of the two inputs. (*The diodes are used to block the 12 VDC signal of the RRGB from the SUB CUB D inputs.*) The decimal point is placed in the third position so the reading is in one-thousandth of an inch.

With the set-up shown, the operator can place the table at any reference point desired, reset the SUB CUB D and make all measurements with regard to this reference. Movement to the left of this reference will provide a negative reading, while movement to the right of the reference will provide a positive numerical reading. Switching the count and quadrature inputs will cause movement left to be positive (+) while movement to the right will be negative (-). As shown in the drawing, the work table is 53.475" to the left of the reference point.

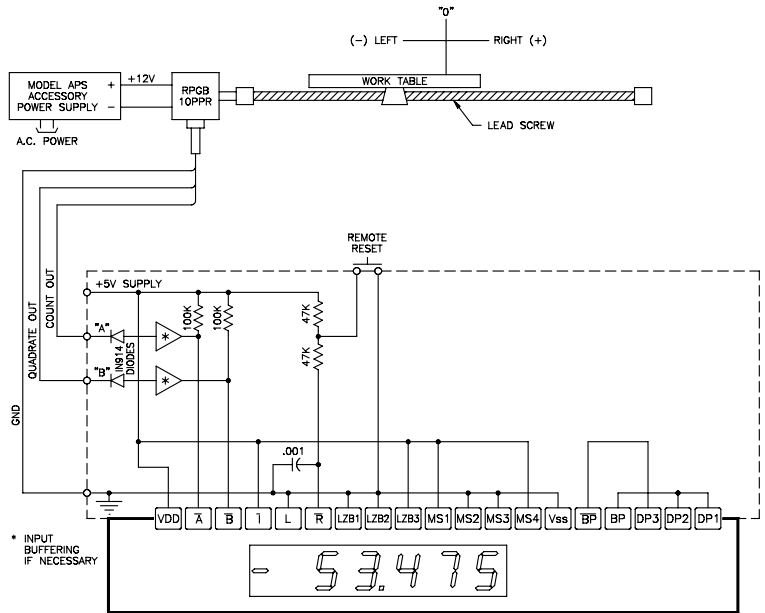

BI-DIRECTION UP/DOWN COUNTING

In this application, a continuous coating of adhesive is applied to a flexible material, which is then taken up on a large roll. Whenever a flaw is detected, the entire process is stopped. Since inertia exists in the system, a certain amount of over-run will occur. This, in turn, will require reversing the system in order to bring the flaw back to the adhesive applicator. The SUB CUB D can be used to correct over-run problem by causing the count to decrease when the process is reversed.

The SUB CUB D is set for Bi-Directional UP/ DOWN counting. The Latch pin is used to "freeze" the display when a defect occurs. Input "A" serves as the count input which is connected to an open collector output LSC Length Sensor. This sensor generates 100 pulses/foot of material travel. (*With 100 pulses/foot going into the counter, the decimal point is selected so that the display will indicate hundredths of feet.*) Input "B" serves as the UP/DOWN direction control pin. This pin is connected to a contact which opens when the system reverses direction, causing the counter to count "down". Since the unit is measuring in hundredths of a foot and very large rolls are used, it is possible that the count could exceed the display capability of six (6) digits. To avoid this problem, a button is connected which, when pressed, causes the unit to display the six (6) most significant digits of the internal 8-digit counter. In addition, the decimal point is removed when the button is held down.

The operation of the system is described as follows. Whenever a flaw is detected, the Latch pin will be pulled high, "freezing" the display at the reading where the flaw occurred. At the same time, the machine is stopped and the applicator is turned off. Due to inertia within the system, internal counts increase until the system comes to a complete stop. The operator then notes the reading on the counter display, releases the latch pin (*the display then reveals the total length*), and reverses the machine until the displayed value matches the noted value. When this match occurs, the flawed area is beneath the applicator area where it can be corrected.

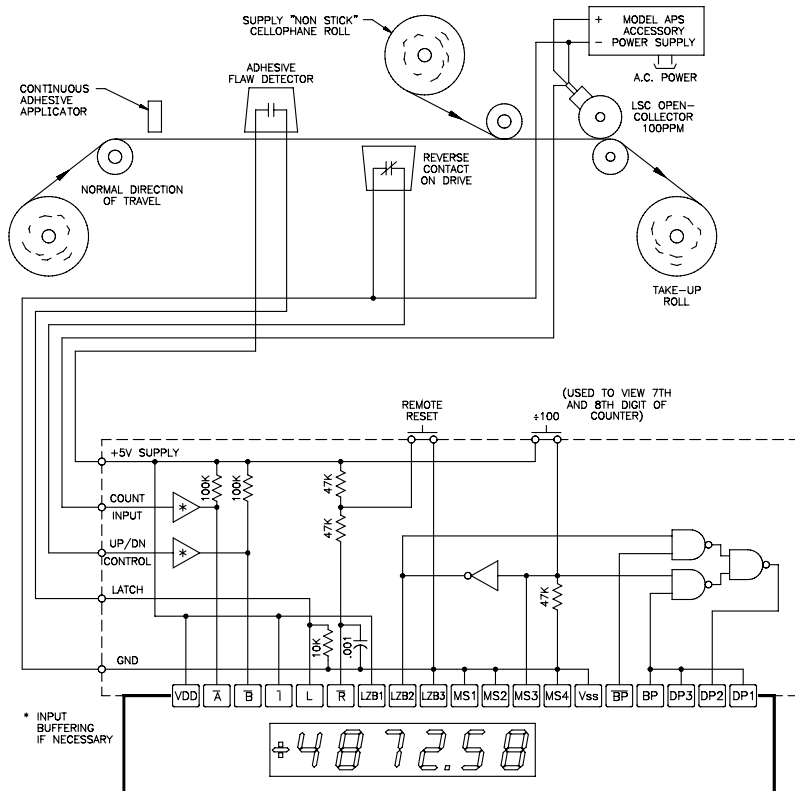

PANEL BEZEL KIT FOR THE SUB CUB D (P/N HWK60000)

This kit provides a convenient way to adapt the SUB CUB D for panel mounting. The kit includes the black plastic bezel, the panel and internal window gaskets, P.C. Board, 12" ribbon cable and mounting screws.



ASSEMBLY

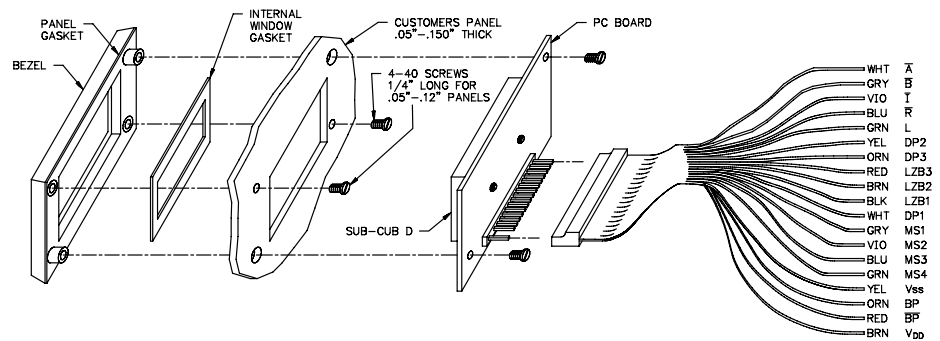

DIMENSIONS & PANEL CUT-OUT In inches (mm)

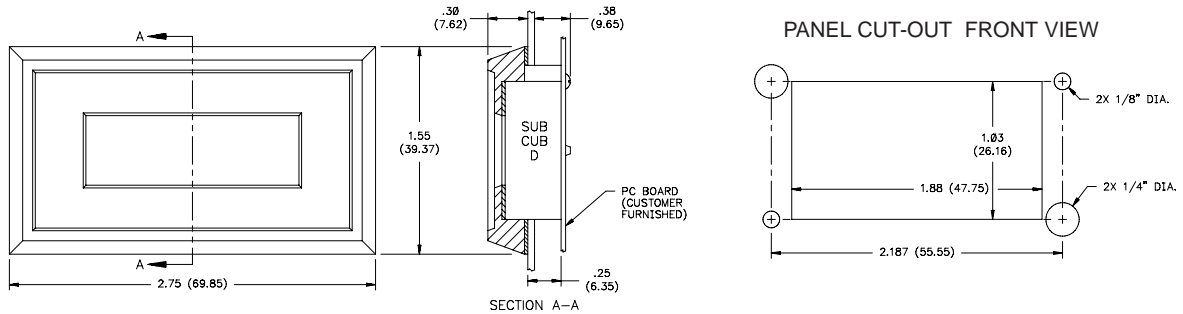

SUB CUB D PROTOTYPING BOARD (P/N DMOSCB04)

This board is a handy way of doing experimental and prototyping work with the SUB CUB D. It easily plugs onto standard 0.1" spacing bread boards. This in turn, greatly simplifies bread board work.

SUB CUB D
PROTOTYPING
BOARD
P/N DMOSCB04

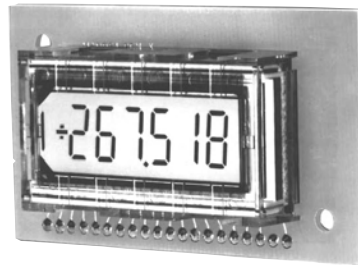

ORDERING INFORMATION

MODEL NO.	DESCRIPTION	PART NUMBER
SCUBD	SUB CUB Display/Counter Module	SCUBD200
HWK 3	*Panel Bezel Kit w/o P.C. Board & Cable	HWK30000
HWK 6	*Panel Bezel Kit w/ P.C. Board & Cable	HWK60000
	Prototype P.C. Board	DMOSCB04
* Does not include SUBCUBD Display/Counter Module. Order SUBCUBD separately.		