

CA SERIES

High-functional Digital Panel Controller



Best partner
for analog sensors

Versatile control with analog sensors

Besides our own analog sensors, it can serve as a controller performing variegated control functions for any type of analog device by any maker.

Applicable SUNX's analog sensors

- Ultra high-speed laser displacement sensor

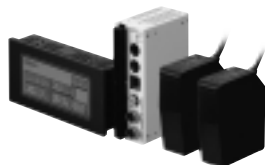

HL-C1 series (p.892~)

- Micro laser displacement sensor



LM10 (p.918~)

- Ultra-compact laser collimated beam sensor

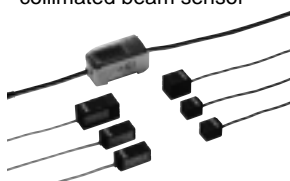

HL-T1 series (p.932~)

- LED collimated beam sensor

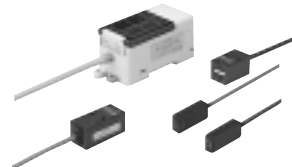

LA-300 series (p.944~)

- Laser collimated beam sensor

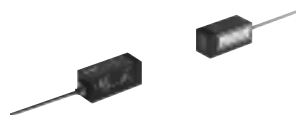

LA series (p.954~)

- High accuracy eddy current type displacement sensor

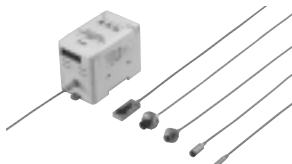

GP-X series (p.972~)
GP-A series (p.986~)

- Slim body analog fiber sensor

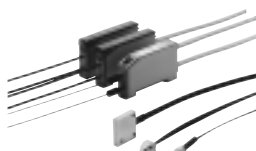

FX-11A (p.172~)

- High-performance digital pressure sensor



DP2 series (p.792~)

- Micro-differential pressure high-precision digital pressure sensor



DP-M2A (p.822~)

High-speed sampling: 1 ms

With a fast sampling rate of 1,000 times/sec., it detects even momentary changes.

Two input channels with various calculations

The CA controller accepts two analog inputs and incorporates five arithmetic functions. Thickness or width measurement is possible using one controller.

- ① A + B
 - ② A - B
 - ③ L - (A + B)
 - ④ $\{(A/B) - 1\} \times 100$
 - ⑤ $(A/B) \times 100$
- A: Input 1
B: Input 2
L: Constant (arbitrary)

Flexible scaling

The conversion of input values to a different scale can be simply done by key operation.

Since the need to convert the displayed value is eliminated, the required information can be confirmed immediately. In addition, convenient unit labels (V, A, J, kPa...) are also provided.

APPLICATIONS

Measuring steel pole eccentricity

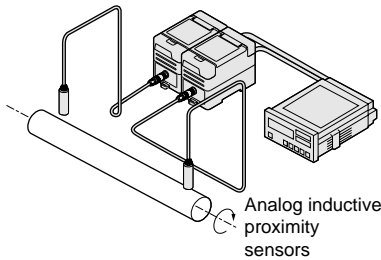

Measuring turbidity in water tank

The turbidity in the water tank can be measured in an analog manner.

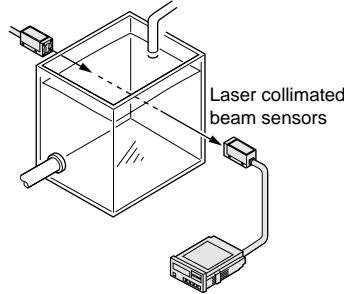

Evaluating height of traveling objects

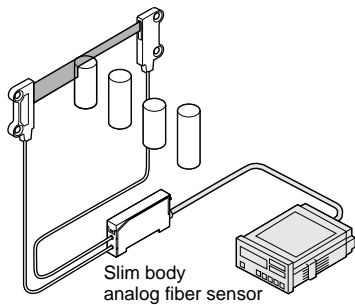

Measuring steel sheet width

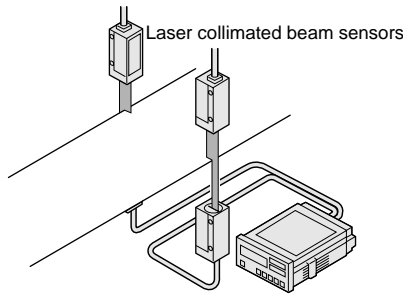

Five separate outputs

Four threshold levels can be set to obtain five separate comparative outputs. This is convenient for a multi-level classification, such as, height judgment.

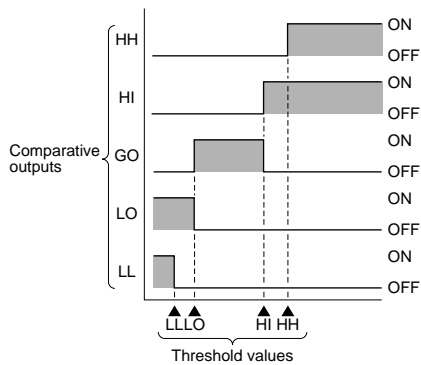

Versatile input / output

There are five types of input ranges and three types of output modes to choose from; total fifteen models are available.

- | | |
|--|--|
| <p>Input range</p> <ul style="list-style-type: none"> ① 4 to 20 mA ② 1 to 5 V ③ ± 1 V ④ ± 5 V ⑤ ± 10 V | <p>Output mode</p> <ul style="list-style-type: none"> ① Relay output ② Transistor output ③ Transistor output with BCD output |
|--|--|

Power supply for sensors

An additional power supply is not necessary for sensors because the CA controller incorporates a 12 V DC 150 mA power supply.

Three types of hold functions

Peak hold, bottom hold and peak-to-peak hold functions are available. Eccentricity or amplitude is easily measured.

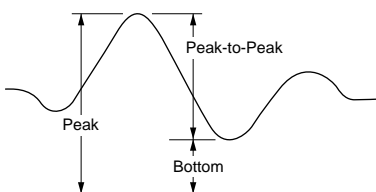



Storage of eight preset values

The CA series stores eight patterns of threshold values, scaling values, etc. Further, since they can be selected by an external input, a change in manufacturing plan can be implemented smoothly.

Various functions

Various functions, such as, power supply ON-delay function, measurement start delay function, hysteresis setting function, etc., which allow versatile control have been incorporated.

ORDER GUIDE

Type	Appearance	Input range	Model No.	Output	
Relay output		4 to 20 mA	CA-R1	Relay contact 1a (HH, HI, LO and LL) Relay contact 1c (GO)	
		1 to 5 V	CA-R2		
		± 1 V	CA-R3		
		± 5 V	CA-R4		
		± 10 V	CA-R5		
Transistor output		4 to 20 mA	CA-T1	NPN open-collector transistor (HH, HI, GO, LO and LL)	
		1 to 5 V	CA-T2		
		± 1 V	CA-T3		
		± 5 V	CA-T4		
		± 10 V	CA-T5		
	With BCD output		4 to 20 mA	CA-B1	NPN open-collector transistor (HH, HI, GO, LO, LL and BCD output)
			1 to 5 V	CA-B2	
			± 1 V	CA-B3	
			± 5 V	CA-B4	
			± 10 V	CA-B5	

NPS
ON / OFF Input

CA
Analog Input

CA2

PS-18V-U
Power Supply

SPECIFICATIONS

Item	Type Basic model No.	Transistor output	
		Relay output CA-R□	With BCD output CA-B□
Supply voltage		100 to 240 V AC ± 10 %	
Power consumption		17 VA or less	
Power supply for sensor		12 V DC + 10%, 150 mA	
Analog input	Input range	CA-□1: 4 to 20 mA, CA-□2: 1 to 5 V, CA-□3: ± 1 V, CA-□4: ± 5 V, CA-□5: ± 10 V	
	Input impedance	Current input: 20 Ω, Voltage input: 1 MΩ (CA-□3: 100 kΩ)	
	No. of inputs	2 Nos.	
	Input method	Single end	Floating
	A/D conversion method	Successive approximation method	
Sampling period	1 ms or more (1,000 times/sec. max.)		
Switching inputs (Process number selection External synchronization Zero-adjustment Reset Auto-reference Hold)	Operation: Negative logic Signal condition: 5 V-CMOS · LSTTL compatible		
Comparative outputs (HH, HI, GO, LO and LL)	Relay contact 1a (HH, HI, LO and LL) Relay contact 1c (GO) • Switching capacity: 250 V 1 A AC (resistive load) 30 V 1 A DC (resistive load) • Electrical life: 100,000 switching operations or more (switching frequency 1,800 operations/hour) • Mechanical life: 50 million switching operations or more (Switching frequency 18,000 operations/hour)	NPN open-collector transistor • Maximum sink current: 100 mA • Applied voltage: 35 V DC or less (between comparative output and COM.) • Residual voltage: 1 V or less (at 100 mA sink current) 0.4 V or less (at 16 mA sink current)	
	Response time	10 ms or less	1ms or less
Data outputs (A0 to D3, POL) (DTV, OR)			BCD 4 digits negative logic NPN open-collector transistor • Maximum sink current: 70mA • Applied voltage: 35 V DC or less (between data output and GND) • Residual voltage: 1 V or less (at 70 mA sink current) 0.4 V or less (at 16 mA sink current)
Measurement value display	3½ digit LED display (letter height: 14.2 mm 0.559 in)		
Display refresh rate	Selectable from 0.2, 0.5, 1, 2.5, 10 or 20 times/sec.		
Display range	- 5999 to + 5999 (' + ' is not displayed)		
Display accuracy	± (0.1 % rdg + 2 digits) at + 23 ± 5 °C + 73.4 ± 41 °F		
Temperature characteristics	± 100 ppm F.S./°C		
Threshold value display	3½ digit LED display (letter height: 8 mm 0.315 in)		
Display range	- 5999 to + 5999 (' + ' is not displayed)		
Process number display	1 digit LED display (letter height: 8 mm 0.315 in)		
Display range	0 to 7		
Function display	HLD (threshold value hold), AG (previous average comparison), 0-ADJ. (zero-adjustment) AR (auto-reference), PH (peak hold), BH (bottom hold) Each abbreviation lights up when the respective function is effective.		
Indicators	Comparative output	HH, HI: Red LEDs (light up when the HH / HI output is ON) GO: Green LED (lights up when the GO output is ON) LO, LL: Orange LEDs (light up when the LO / LL output is ON)	
	External synchronization input	Orange LED (lights up when the external synchronization input is ON)	
	LL-HH value display	Orange LED (lights up when LL and HH values are shown on the lower and upper threshold value displays)	
Main functions	Process number selection, arithmetic, hold, scaling, auto-reference, power supply ON-delay, start delay, hysteresis setting, etc.		
Environmental resistance	Ambient temperature	0 to + 50 °C + 32 to + 122 °F (No dew condensation), Storage: - 20 to + 70 °C - 4 to + 158 °F	
	Ambient humidity	20 to 85 % RH, Storage: 20 to 95 % RH	
	Noise immunity	Power line: 1,500 Vp, 10 ms cycle, 0.5 μs pulse width; Radiation: 300 Vp, 10 ms cycle, 0.5 μs pulse width (with noise simulator)	
	Voltage withstandability	2,000 V AC for one min. between the input, the power and F.G., and between all terminals connected together and enclosure	
	Insulation resistance	100 MΩ, or more, with 500 V DC megger between the input, the power and F.G., and between all terminals connected together and enclosure	
	Vibration resistance	10 to 55 Hz frequency, 1.5 mm 0.059 in amplitude in X, Y and Z directions for two hours each	
Shock resistance	981 m/s ² acceleration (100 G approx.) in X, Y and Z directions for three times each		
Memory protection	Non-volatile memory (EEPROM)		
Material	Enclosure: ABS		
Connecting method	Screw-on terminal block [BCD output type: Screw-on terminal block and connector (Note)]		
Weight	500 g approx.		
Accessory	Unit seal: 1 set		

Note: Purchase the mating connector for the BCD output type separately.

Recommended mating connector: HIF3BA-34D-2.54R (Manufactured by Hirose Electric CO., LTD.)

AXM134415A (Manufactured by Matsushita Electric Works, Ltd.)

I/O CIRCUIT AND WIRING DIAGRAMS

Terminal arrangement

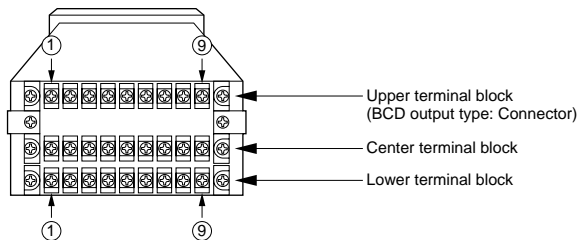

• Upper terminal block

Relay output type

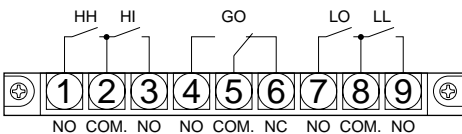

Transistor output type

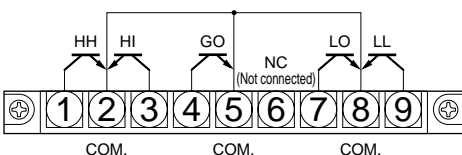

Transistor output with BCD output

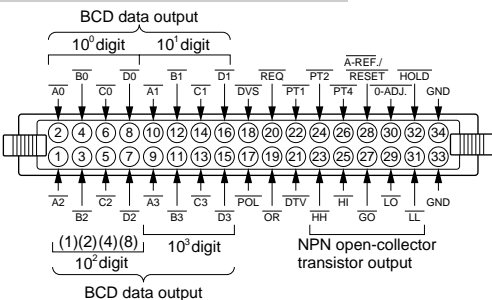

<Signal designation>

- A0 to D3: BCD data output
- POL: Polarity signal output
+ ' when Low, - ' when High
- DVS: Device select input
Input signal to enable BCD data output
BCD output is enabled when it is Low.
- OR: Over-range output
Low signal is output when input value exceeds input range
- REQ: Request input
Data request input in PLC (programmable logic controller) mode
- DTV: Data valid output
Low signal is output when BCD data is established
- PT1 to PT4: Process number selection inputs
- A-REF / RESET: Auto-reference / Reset input
- 0-ADJ.: Zero-adjustment input
- HOLD: Hold input
- HH, HI, GO, LO, LL: Comparative outputs
- GND: Ground

• Center terminal block and lower terminal block

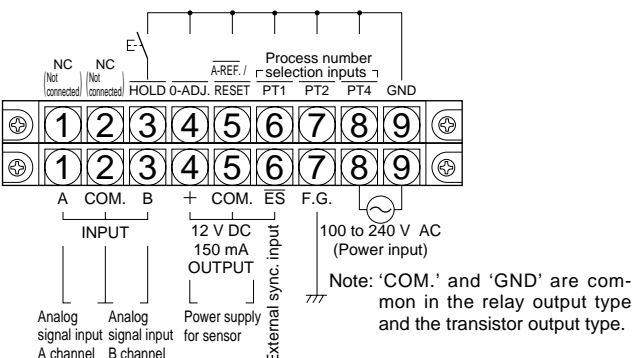

BCD output time chart

• PC (personal computer) mode

External synchronization input operation

① Without function

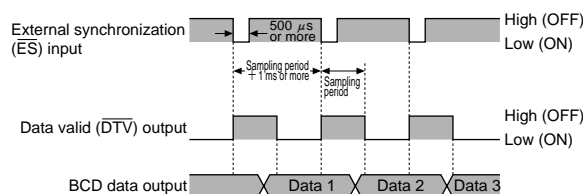

Measurement is done when \overline{ES} input falls and measured data is established when \overline{DTV} output becomes low.

② With function

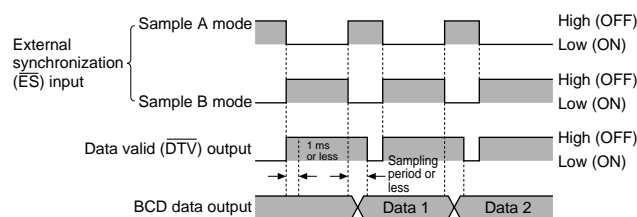

In the Sample A mode, continuous measurement starts at the fall of the \overline{ES} signal and ends when the \overline{ES} signal is detected as High.

In the Sample B mode, continuous measurement starts on detecting the \overline{ES} signal as High (within 1 ms after its rise) and ends on detecting it as Low (within one sampling period after its fall).

The DTV output becomes Low within one sampling period after the end of measurement, and the measurement data is established.

run mode

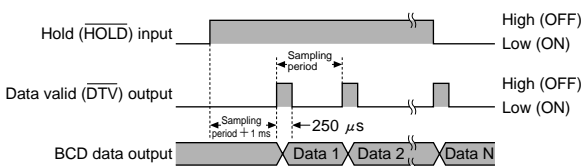

If the \overline{HOLD} input is held High, the measurement data is output every sampling cycle.

• PLC (programmable logic controller) mode

Single sampling

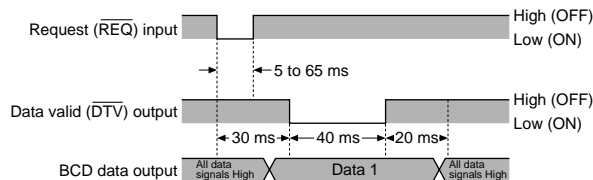

The \overline{DTV} output becomes Low 30 ms approx. after the fall of the \overline{REQ} input, and the measurement data is established. Read the measurement data at the time the \overline{DTV} output becomes Low. The \overline{DTV} output becomes High after remaining Low for 40 ms, and after another 20 ms, all data becomes High.

Continuous sampling

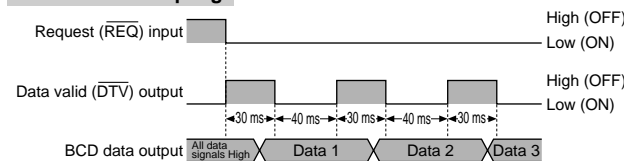

If the \overline{REQ} input is held Low, the measurement data is updated every 70 ms.

I/O CIRCUIT AND WIRING DIAGRAMS

Input circuit diagram

ES, REQ, DVS

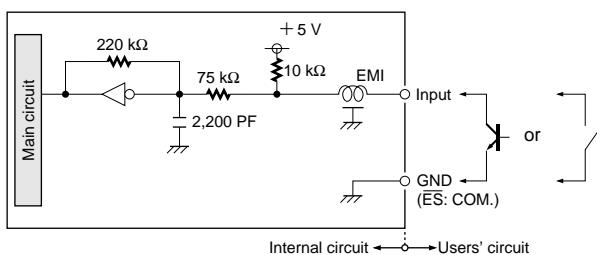

Output circuit diagram

Relay output

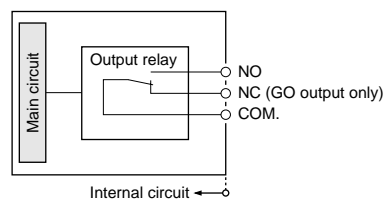

A-REF., RESET, 0-ADJ., PT1 to PT4, HOLD

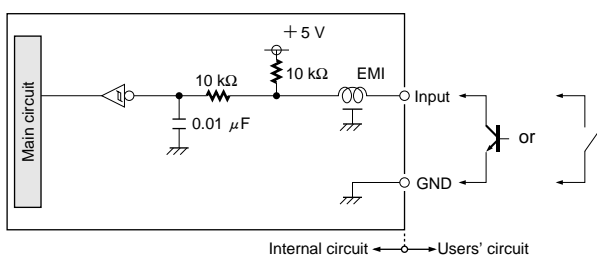

Transistor output

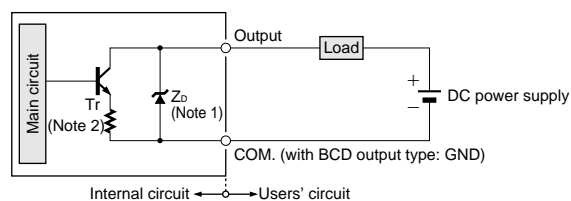

Notes: 1) The zener diode is incorporated only for the comparative output.
2) The resistance is incorporated only in the transistor output type CA-T□.

Symbols ... Zd: Surge absorption zener diode
Tr: NPN output transistor

ON / OFF Input
NPS

Analog Input
CA

CA2

Power Supply
PS-18V-U

PRECAUTIONS FOR PROPER USE



This product is not a safety controller. It does not possess control functions needed for accident prevention or safety maintenance.

Functional description

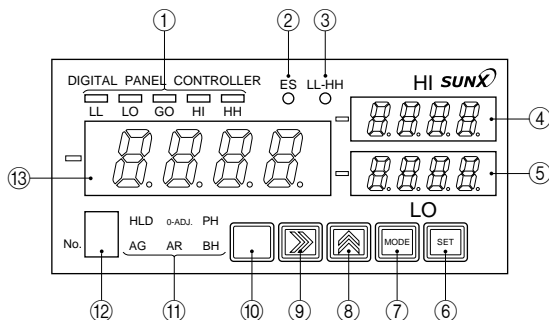

	Description	Function
①	Comparative output indicators	Light up, respectively, when LL, LO, GO, HI and HH comparative outputs are ON.
②	External synchronization input indicator	Lights up when the external synchronization input is ON.
③	LL-HH value display indicator	Lights up when LL-HH value display is selected with key in the RUN mode. The upper threshold value display shows the 'HH' value and the lower threshold value display shows the 'LL' value.
④	Upper threshold value display	'HI' or 'HH' value is displayed in the RUN mode. In the SET mode, the set values and contents are displayed.
⑤	Lower threshold value display	'LO' or 'LL' value is displayed in the RUN mode. In the SET mode, the set values and contents are displayed.
⑥	SET key	Each set value is entered.
⑦	MODE key	Pressing the key changes the mode.
⑧	Increment key	At each press, it increments each digit of the set value by one.
⑨	Shift key	It shifts the settable digit.

	Description	Function
⑩	SECRET key	It is an auxiliary key to move from the RUN mode to the SET mode. Pressing the MODE key while pressing the SECRET key changes the mode to the SET mode.
⑪	Function display	HLD (Threshold value hold) AG (Previous average comparison) 0-ADJ. (Zero-adjustment) AR (Auto-reference) PH (Peak hold) BH (Bottom hold) Each abbreviation lights up when the respective function is effective.
⑫	Process number display	The process number which is selected from eight patterns of storage is displayed.
⑬	Measurement value display	The measurement value is displayed in the RUN mode. (Except when different functions are used.) The menu or the error message is displayed in the SET mode.

Functions

Function	Details
Arithmetic operations	This function computes data from Channel A and Channel B inputs. CH-A: Channel A data. CH-B: Channel B data. A + B: Addition of Channel A data and Channel B data. A - B: Subtraction of Channel B data from Channel A data. L - (A + B): Subtraction of A + B from constant L. (A/B - 1) × 100: Computes the difference between Channel A data and Channel B data as a percentage of Channel B data. A/B × 100: Computes the ratio (%) of Channel A data to Channel B data.
Hysteresis setting	This function determines the hysteresis (difference between ON and OFF points) of the comparative outputs.
LSD (least significant digit) fixed '0' display	This function fixes the least significant digit display at '0'. It does not affect the comparison operation.

Function	Details
Auto-reference	This function automatically corrects the threshold values according to a change in the reference value. When the auto-reference (A-REF.) input is made Low, the measured value at that instant is added to each threshold value (HH, HI, LO and LL). Auto-reference (A-REF.) input: High (OFF) / Low (ON) t: 1 ms or more

PRECAUTIONS FOR PROPER USE

Functions

Function	Details
Sampling period selection	This function selects the sampling period from 1 to 5,000 ms.
Decimal point position setting	This function sets the place of the decimal point on the display.
Scaling	This function converts the input value range to an arbitrary output value range.
Threshold value display alternation	This function changes the threshold values displayed on the upper and lower value displays during operation. LO, HI Alternation LL, HH
Zero-adjustment (0-ADJ.)	By making the zero-adjust (0-ADJ.) input Low, the measured pressure is forcibly set to '0' and measurement is done by taking this input value as the reference ('0').
Zero-adjustment (0-ADJ.) clear	The input value which was forcibly set to '0' by the zero-adjust (0-ADJ.) function is restored to the original value.
Zero suppression	This function removes unnecessary zeros in upper digits. (e.g.) 0460 → 460
Previous average comparison	This function neglects slow changes, such as drift, and captures only sudden changes.
Operation delay	This function sets the delay time between the actual start of A/D conversion and the input of the start signal (HOLD or ES).
Timer	<p>ON-delay: Neglects short period signals. OFF-delay: Prolongs output signals by a fixed time interval.</p> <p>Time chart Sensing condition</p> <p>Without timer</p> <p>ON-delay</p> <p>OFF-delay</p> <p>Timer period: T = 0 to 1,000 ms</p>
Trigger mode set	<p>It selects the function (peak hold, bottom hold, peak to peak hold) operation timing.</p> <p>RUN (run) mode: Normal processing</p> <p>Sample A (SPLR) mode: Operation when external synchronization signal (ES) input is Low (when function is used)</p> <p>Sample B (SPLB) mode: Operation when external synchronization (ES) input is High (when function is used)</p>
Power supply ON-delay	This function starts measurement after the set delay time after switching on the power supply.
Comparison value selection	<p>This function sets the operation of the comparative outputs when a function (peak hold, bottom hold, peak-to-peak hold) is used.</p> <p>Comp: The comparative output is obtained by comparison between the input value and the threshold value.</p> <p>Disp: The comparative output is obtained by comparison between the display value and the threshold value.</p>
Analog input monitor	This function displays the analog input data directly on the display without scaling.

Function	Details
Process number selection	<ol style="list-style-type: none"> Threshold values (HH, HI, LO and LL) Scaling values (Zero point, Span point) Hysteresis 0-ADJ.(Zero-adjustment) clear Decimal point position Comparison method (High-GO-Low comparison, Independent comparison) <p>A total of eight combinations of the above set values are stored in the memory and can be selected by key operation or by external inputs.</p>
Process number selection control	This function determines whether the selection of the process number is by key operation at the front panel or by the logic combination of the external inputs at the rear.
Threshold value hold	The measurement is stopped and the display value is held at the instant the display value exceeds the threshold value.
Comparison method setting	<p>This function determines how to activate the comparative outputs by comparison of the display value with the threshold values.</p> <p>• High-GO-Low comparison (HGL)</p> <p>The threshold values must fulfill the following conditions. ① LL<LO ② LO<HI - Hysteresis ③ HI<HH</p> <p>• Independent High-ON comparison (Hion)</p> <p>Each comparative output is independent. GO output is turned ON only when all other comparative outputs are OFF.</p> <p>• Independent High-Low-ON comparison (Hl-on)</p> <p>Each comparative output is independent. GO output is turned ON only when all other comparative outputs are OFF.</p>

PRECAUTIONS FOR PROPER USE

Functions

Function	Details
Comparison method setting (Continued from the previous page)	<p>• Independent Low-ON comparison (LOWON)</p> <p>Each comparative output is independent. GO output is turned ON only when all other comparative outputs are OFF.</p>
Peak hold	<p>• Run (RUN) mode In normal condition, the maximum measured value is displayed and the display is reset when reset (RESET) input falls Low.</p> <p>• Sample A (SPLR) mode • Sample B (SPLB) mode The maximum value measured in the period the external synchronization (ES) input is Low (High in case of Sample B mode) is held and displayed.</p>
Peak-to-Peak hold	<p>• Run (RUN) mode In normal condition, the difference in the maximum and the minimum measured values is displayed, and the display is reset when reset (RESET) input falls Low.</p> <p>• Sample A (SPLR) mode • Sample B (SPLB) mode The difference in the maximum and the minimum values measured in the period the external synchronization (ES) input is Low (High in case of Sample B mode) is held and displayed.</p>

Function	Details
Bottom hold	<p>• Run (RUN) mode In normal condition, the minimum measured value is displayed, and the display is reset when reset (RESET) input falls Low.</p> <p>• Sample A (SPLR) mode • Sample B (SPLB) mode The minimum value measured while the external synchronization (ES) input is Low (High in case of Sample B mode) is held and displayed.</p>
Hold	<p>• Run (RUN) mode The display is held at the value at which the hold (HOLD) input falls Low and normal operation is restored when it rises to High.</p> <p>• Sample A (SPLR) mode • Sample B (SPLB) mode The display is held at the value in which the external synchronization (ES) input falls Low for the first time after power-up and does not change till its next falling down.</p>
Display OFF	This function turns off the measured value display.
Display refresh rate selection	This function selects the refresh rate of the measured value display from 0.2, 0.5, 1, 2.5, 10 or 20 times/sec. It does not affect the comparison operation.

DIMENSIONS (Unit: mm in) The CAD data in the dimensions can be downloaded from the SUNX website: <http://www.sunx.co.jp/>

CA-□ Digital panel controller

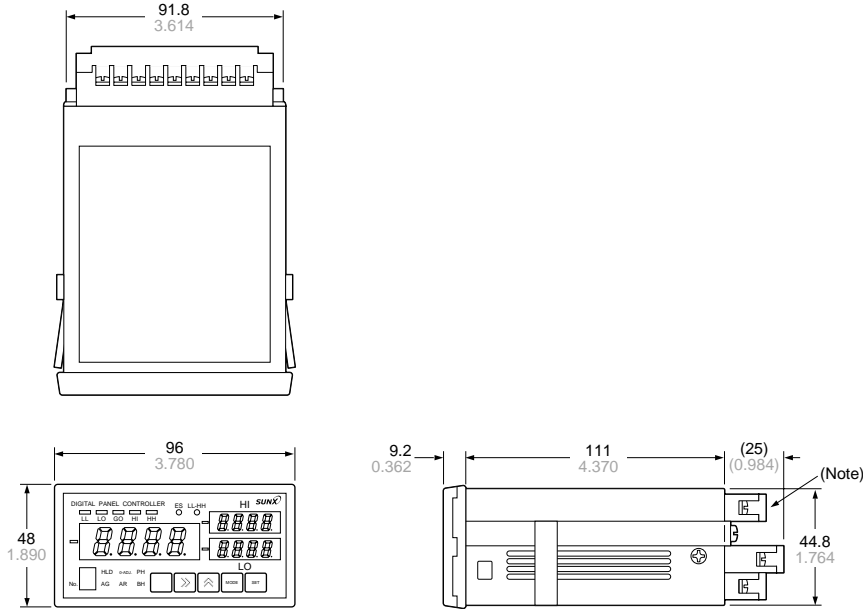

Note: Connector in case of **CA-B□**.
 HIF3BA-34PA-2.54DS (Manufactured by Hirose Electric CO., LTD.)

Recommended mating connector
 HIF3BA-34D-2.54R (Manufactured by Hirose Electric CO., LTD.),
 AXM134415A (Manufactured by Matsushita Electric Works, Ltd.) or
 equivalent

Panel cut-out dimensions

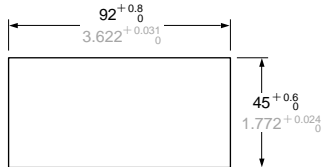

Note: The panel thickness should be 0.5 to 5 mm 0.020 to 0.197 in.