

CA2 SERIES

Ultra-compact Digital Panel Controller



Convenient functions packed in a small body!



Ultra-compact

Ultra-compact size of W 48 × H 24 × D 65.5 mm
W 1.890 × H 0.945 × D 2.579 in.
It can be mounted even in a tight space.



Large display

Though the size is compact, the measurement display uses 4 digit, 8 mm 0.315 in letter height, red 7-segment LEDs.

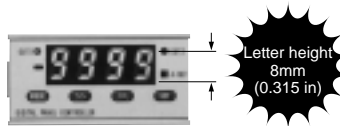

Flexible scaling

The conversion of input values to a different scale can be simply done by key operation. Since the need to convert the displayed value is eliminated, the required information can be confirmed immediately.

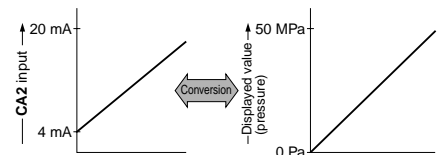

Incorporates useful functions

Changing each threshold level is cumbersome

► Auto-reference function is useful!

Auto-reference function is an original function developed by SUNX by which, for example, if there is a reference pressure change during pressure measurement, the change is automatically added to the threshold level. Hence, you need not change the threshold level every time.

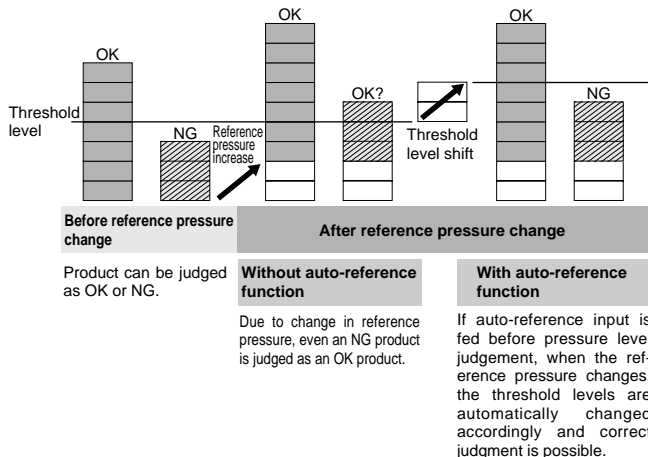

Measurement with master workpiece as standard

► Zero-adjust function is useful!

Zero-adjust function enables setting of the standard measured value to '0'. Hence, it is useful for an error check by taking the measured master workpiece value as standard.

Application

· Judging object height

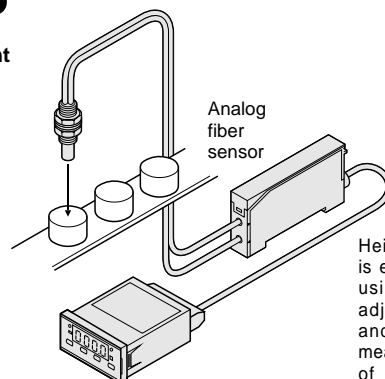

Height judgment is easily done by using the zero-adjust function and setting the measured values of the master workpiece as '0'.

APPLICATIONS

Thickness distinction

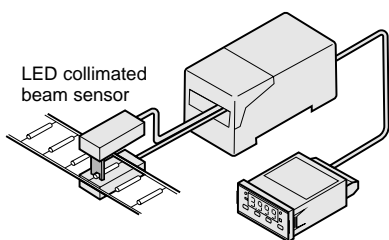

Detecting improper lathe chuck tightening

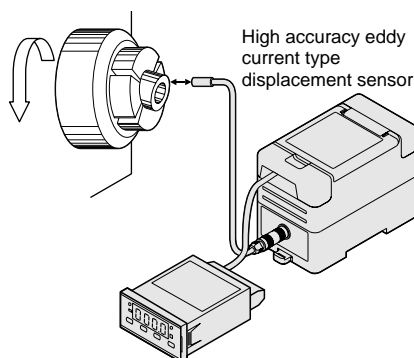

Measuring inner diameter of rings

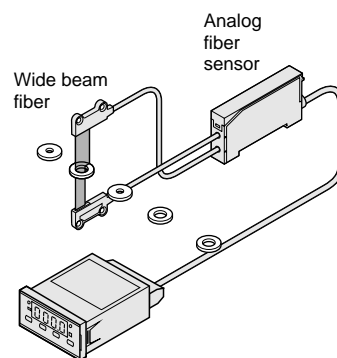

Measuring turbidity in water tank

The turbidity in the water tank can be measured in an analog manner.

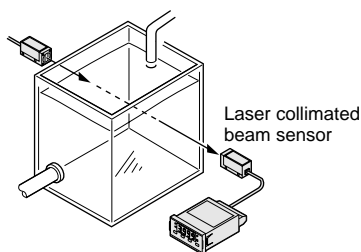

Two independent outputs incorporated

Two independent comparative outputs (OUT 1, OUT 2) have been incorporated. High output comparison operation / low output comparison operation can be set for each output. Further, the hysteresis for each of the outputs can be set arbitrarily.

OUT 1: 'H', OUT 2: 'L'

Independent high and low output comparison operation

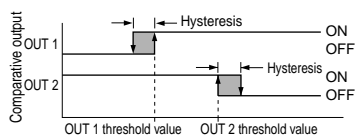

OUT 1: 'H', OUT 2: 'H'

Independent two high output comparison operation

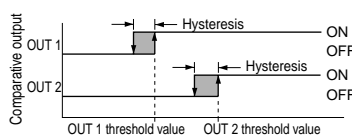

OUT 1: 'L', OUT 2: 'L'

Independent two low output comparison operation

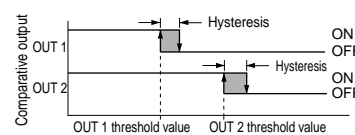

Various input ranges

The CA2 series is provided with 5 types of input ranges: 4 to 20 mA, 1 to 5 V, ± 1 V, ± 5 V and ± 10 V. It can be used with any suitable analog sensor.

- 4 to 20 mA
 - 1 to 5 V
 - ± 1 V
 - ± 5 V
 - ± 10 V
- 5 types of input ranges are available.

Low price

It saves space by incorporating various functions in an extremely small size. Further, it is low priced.

CA2

ORDER GUIDE

Appearance	Input range	Model No.	Output
	4 to 20 mA	CA2-T1	NPN open-collector transistor
	1 to 5 V	CA2-T2	
	± 1 V	CA2-T3	
	± 5 V	CA2-T4	
	± 10 V	CA2-T5	

SPECIFICATIONS

Model No.		CA2-T1	CA2-T2	CA2-T3	CA2-T4	CA2-T5
Item						
Supply voltage		24 V DC $\pm 10\%$ Ripple P-P 10 % or less				
Power consumption		2.8 W or less				
Analog inputs	Input range	4 to 20 mA	1 to 5 V	± 1 V	± 5 V	± 10 V
	Input impedance	20 Ω	1 M Ω			
	No. of inputs	1 No.				
	Input method	Single end input				
	A/D conversion method	Successive approximation method				
	Sampling rate	Selectable from 200 times/sec., 20 times/sec., 10 times/sec. or 5 times/sec.				
Zero-adjust input (0-ADJ.) Auto-reference input (A-REF.)		Input condition: Non-voltage contact or NPN open-collector transistor input Signal condition: Negative logic, Input time duration 10 ms or more Signal level: ON ... 1.5 V or less (output current: 10 mA or less) OFF ... Supply voltage or open Guaranteed No. of zero-adjust input usage: 10 million times or less (for zero-adjust back-up setting)				
Start / hold input		High level (supply voltage, or open): Start, Low level (1.5 V or less): Hold				
Comparative outputs (OUT 1, OUT 2)		NPN open-collector transistor • Maximum sink current: 100 mA • Applied voltage: 35 V DC or less (between comparative output and GND) • Residual voltage: 1.3 V or less (at 100 mA sink current) 0.4 V or less (at 16 mA sink current)				
	Utilization category	DC-12 or DC-13				
	Response time	5 ms or less (when start / hold input is used at a sampling rate of 200 times/sec.)				
	Hysteresis	Variable from 1 to 3,999				
Display		4 digit 7-segment red LED display (letter height: 8 mm 0.315 in)				
Display	Display refresh rate	Selectable from 20 times/sec., 10 times/sec., 5 times/sec., 2.5 times/sec., 1 time/sec. or 0.5 time/sec.				
	Display range	Selectable span of 4,000 Nos. between - 9999 to + 9999 is displayed. ('+' is not displayed)				
	Display accuracy	$\pm (0.1\% \text{ F.S.} + 1 \text{ digit})$ at $23 \pm 5\text{ }^\circ\text{C}$ $73.4 \pm 41\text{ }^\circ\text{F}$, 35 to 85 % RH				
	Temperature characteristics	$\pm 0.5\% \text{ F.S.}$ over 0 to + 50 $^\circ\text{C}$ + 32 to + 122 $^\circ\text{F}$				
Setting resolution		1 digit				
Threshold value setting range		- 9999 to + 9999				
Indicators	Polarity indication	Red LED (lights up when the displayed value or the threshold value is negative)				
	OUT 1 operation	Orange LED (Measurement mode: Lights up when OUT 1 is ON. Blinks when display is changed to OUT 1 threshold value display. Setting mode: Blinks when OUT 1 threshold value and comparison conditions are set or when zero scale of scale setting function is set.)				
	OUT 2 operation	Orange LED (Measurement mode: Lights up when OUT 2 is ON. Blinks when display is changed to OUT 2 threshold value display. Setting mode: Blinks when OUT 2 threshold value and comparison conditions are set or when full scale of scale setting function is set.)				
	Auto-reference operation	Green LED (lights up when auto-reference function is used)				
Functions		Auto-reference function, zero-adjust function, scale setting function, threshold value setting function, hysteresis setting function, comparative output timer function, start / hold function, memory clear function, power supply ON-delay function etc.				
Environmental resistance	Pollution degree	3 (Industrial environment)				
	Ambient temperature	0 to + 55 $^\circ\text{C}$ + 32 to + 131 $^\circ\text{F}$ (No dew condensation), Storage: - 20 to + 70 $^\circ\text{C}$ - 4 to + 158 $^\circ\text{F}$				
	Ambient humidity	35 to 85 % RH, Storage: 35 to 85 % RH				
	EMC	EN 50081-2, EN 50082-2, EN 61000-6-2				
	Voltage withstandability	1,500 V AC for one min. between all supply terminals connected together and enclosure				
	Insulation resistance	100 M Ω , or more, with 500 V DC megger between all supply terminals connected together and enclosure				
	Vibration resistance	10 to 55 Hz frequency, 1.5 mm 0.059 in amplitude in X, Y and Z directions for two hours each				
Shock resistance	294 m/s ² (30 G) acceleration in X, Y and Z directions for three times each					
Back-up memory		Non-volatile memory (EEPROM), Guaranteed write operations: 1,000,000 or less				
Material		Enclosure: Polycarbonate				
Connecting method		Terminal block connection				
Weight		55 g approx.				

ON / OFF Input

NPS

Analog Input

CA

CA2

Power Supply

PS-18V-U

I/O CIRCUIT AND WIRING DIAGRAMS

Input circuit diagram

IN, ST / HOLD, 0-ADJ. / A-REF.

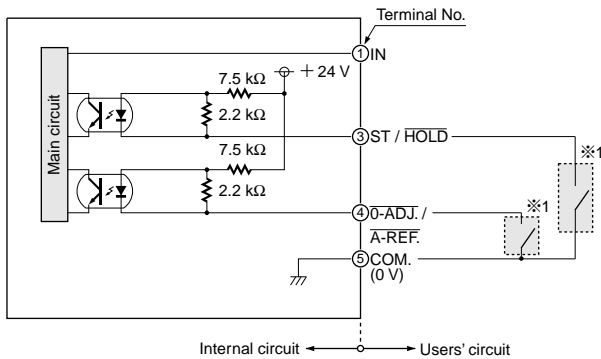

Terminal arrangement

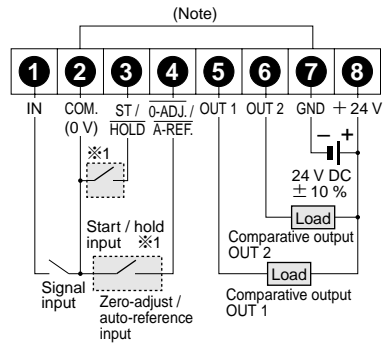

Note: COM. (0 V) is internally connected to GND.

Output circuit diagram

OUT 1, OUT 2

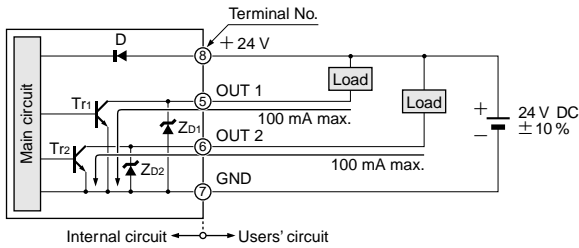

Symbols ... D: Reverse supply polarity protection diode
Zd1, Zd2: Surge absorption zener diode
Tr1, Tr2 : NPN output transistor

※1

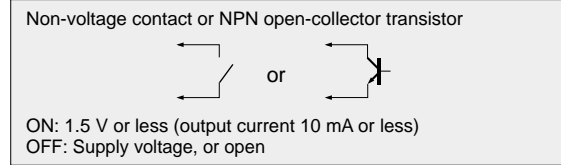

PRECAUTIONS FOR PROPER USE



This product is not a safety controller. It does not possess control functions needed for accident prevention or safety maintenance.

Functional description

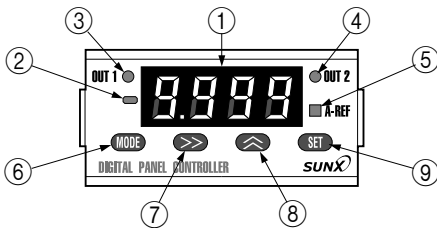

Description	Function
① Display (Red)	<ul style="list-style-type: none"> Measurement mode: Display of scaled measured value, input value, OUT 1 threshold value and OUT 2 threshold value Setting mode: Display of setting menu and setting parameters Error: Display of error code
② Polarity indicator (Red)	<ul style="list-style-type: none"> Lights up when the displayed value or the threshold value is negative.
③ OUT 1 operation indicator (Orange)	<ul style="list-style-type: none"> Measurement mode: Lights up when OUT 1 is ON. Blinks when display is changed to OUT 1 threshold value display. Setting mode: Blinks when OUT 1 threshold value and comparison conditions are set or when zero scale of scale setting function is set.

Description	Function
④ OUT 2 operation indicator (Orange)	<ul style="list-style-type: none"> Measurement mode: Lights up when OUT 2 is ON. Blinks when display is changed to OUT 2 threshold value display. Setting mode: Blinks when OUT 2 threshold value and comparison conditions are set or when full scale of scale setting function is set.
⑤ Auto-reference operation indicator (Green)	<ul style="list-style-type: none"> Lights up when auto-reference function is used.
⑥ Mode key	<ul style="list-style-type: none"> When the set key is pressed while pressing the mode key, the sensor changes from measurement mode to setting mode. Further, it changes the mode in the setting mode.
⑦ Shift key	<ul style="list-style-type: none"> It shifts the settable digit.
⑧ Increment key	<ul style="list-style-type: none"> It changes the setting or the numerical value to be set. The setting is shown on the display. The setting is selected by the increment key and confirmed by the set key. When a numerical value is to be set, the settable digit blinks. The blinking digit is incremented by pressing the increment key. It can also be used to directly display the input value.
⑨ Set key	<ul style="list-style-type: none"> It changes the item to be set in the setting mode. The item to be set and the conditions are confirmed by the set key. It can also be used to change to threshold value display in the measurement mode.

PRECAUTIONS FOR PROPER USE

Functions at a glance

Function	Details
Scale setting function	<ul style="list-style-type: none"> Using this function, the input value range can be converted to an arbitrary display range (span of 4,000 Nos. within - 9,999 to + 9,999). The values which are desired to be displayed by the extreme values of the input value range are input as 'zero scale' and 'full scale'. <p>Example: In case 'beam interrupted width' is to be displayed when using the analog sensor LA-510 having an output of 1 to 5 V.</p> <p>Since the LA-510 outputs an analog voltage of 1 to 5 V, CA2-T2, which has an input range of 1 to 5 V, is used.</p> <p>If Zero scale: 1500 Full scale: 0000</p> <p>[Full beam received condition] [Full beam interrupted condition]</p>
Threshold value setting function	<ul style="list-style-type: none"> Using this function, the threshold value for OUT 1 and OUT 2 can be set from - 9,999 to + 9,999. 'H' and 'L' are displayed in the threshold value setting mode. If 'H' is set, high output comparison operation is obtained, and if 'L' is set, low output comparison operation is obtained. <p>Each comparative output and each threshold value is independent.</p>
Hysteresis setting function	<ul style="list-style-type: none"> This function enables independent setting of the hysteresis (difference between ON and OFF points) of the comparative outputs (OUT 1, OUT 2) in the range 1 to 3,999.
Auto-reference function	<ul style="list-style-type: none"> This function automatically compensates the threshold values according to a change in the reference input value. When the auto-reference (A-REF.) input is made Low, the measured value at that instant is added to each threshold value (OUT 1, OUT 2 set values) to give the new threshold values. <ul style="list-style-type: none"> It can be selected whether auto-reference function is to be used or not. Auto-reference operation indicator (green) lights up when auto-reference function is used. Auto-reference function cannot be used when zero-adjust function is selected.

Function	Details
Zero-adjust function	<ul style="list-style-type: none"> By making the zero-adjust (0-ADJ.) input low for 10 ms, or more, the output value is forcibly made '0' and measurement is then done by taking the input value of this instant as standard '0'. Zero-adjust function cannot be used when auto-reference function is selected. If zero-adjust backup is used, the input value is stored even when the power supply is switched off. To cancel the zero-adjust function, put the zero-adjust setting to OFF. In this case, the standard value will return to the value before zero-adjust input.
Comparative output timer function	<ul style="list-style-type: none"> ON-delay: It makes short duration sensing signal ineffective. OFF-delay: It extends the output signal by a fixed time period (0 to 99.99 sec.). <p>Time chart</p> <p>Timer period T: 0 to 99.99 sec. (settable in units of 0.01 sec.)</p>
Start / Hold function	<ul style="list-style-type: none"> This function maintains the output display and the comparative outputs (OUT 1, OUT 2) based on the input value at start / hold (ST / HOLD) input falling edge and restores normal operation at the start / hold input rising edge. <p>Input signal condition t: 10 ms or more (sampling rate 200 times/sec.) 100 ms or more (sampling rate 20 times/sec.) 200 ms or more (sampling rate 10 times/sec.) 400 ms or more (sampling rate 5 times/sec.)</p>
Memory clear function	<ul style="list-style-type: none"> This function clears all settings and returns the controller to the initial setting condition. This function is activated by pressing the set key while pressing the shift key for 3 sec. or more.
Power supply ON-delay function	<ul style="list-style-type: none"> This function delays the commencement of measurement by the set time period (0 to 9,999 sec.) from the instant the power supply is switched on.
Display refresh rate selection function	<ul style="list-style-type: none"> This function selects the refresh rate of the measurement value display from 20 times/sec., 10 times/sec., 5 times/sec., 2.5 times/sec., 1 time/sec. and, 0.5 time/sec. It does not affect the comparison operation.
Sampling rate selection function	<ul style="list-style-type: none"> This function selects the sampling rate for measurement from 200 times/sec., 20 times/sec., 10 times/sec. and, 5 times/sec.
Decimal point position setting function	<ul style="list-style-type: none"> This function sets the position of the decimal point.
Zero-suppression setting function	<ul style="list-style-type: none"> This function removes an unnecessary '0' in the upper digits. (e.g.): 0460 → 460
LSD (least significant digit) fixed '0' display function	<ul style="list-style-type: none"> This function fixes the least significant digit display to '0'. It merely fixes the least significant digit display and does not affect the comparison operation.
Key-protect function	<ul style="list-style-type: none"> This function makes the increment key ineffective so that the set conditions are not changed by mistake. [When the key-protect function is canceled, the increment key is usable.]

CA2

PRECAUTIONS FOR PROPER USE

Ferrite clamp

- If this product is to be used as a CE (European standard EMC Directive) approved product, make sure to connect ferrite clamps, with one loop, on all the connection cables, as shown in the right figure. Also, make sure not to exceed 10 m 32.808 ft in cable length.

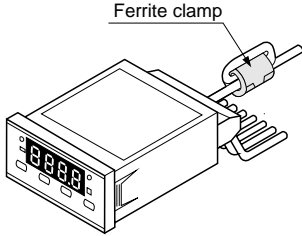

<Recommended ferrite clamp>
 Manufactured by TDK Corporation:
 Noise filter for single line
 ZCAT3035-1330

DIMENSIONS (Unit: mm in) The CAD data in the dimensions can be downloaded from the SUNX website: <http://www.sunx.co.jp/>

CA2-□ Digital panel controller

Panel cut-out dimensions

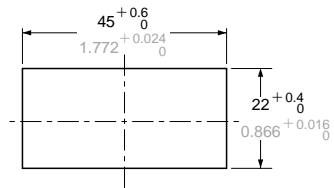
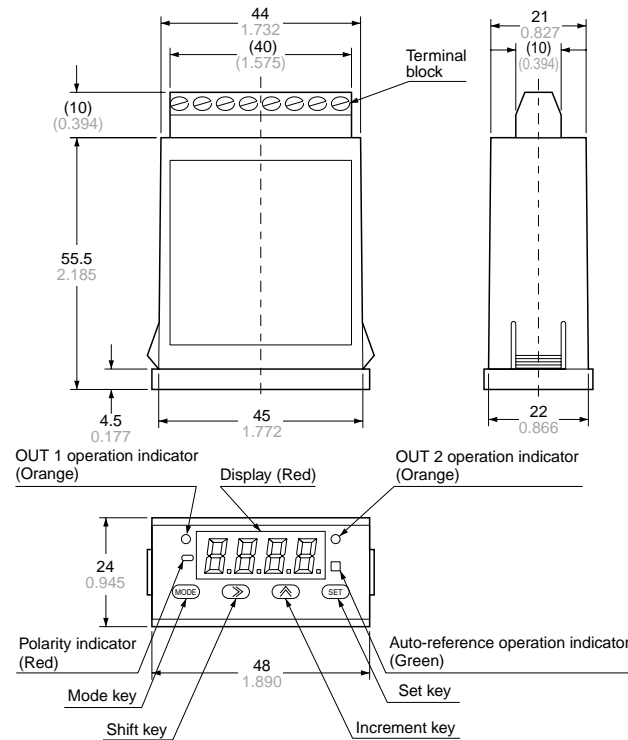

Note: The panel thickness should be 0.5 to 4 mm 0.020 to 0.157 in.