

GD SERIES

Metal-sheet Double-feed Detector



From ultra-thin lead frames to iron sheets...
Double feed detection
of various metal sheets

Double metal sheets reliably detected

The high-end **GD** sensing technology reliably detects double feeds of any metal sheet 0.01 mm 0.0004 in, or more, thick.

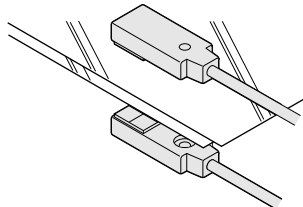

Easy sensitivity setting with actual samples

Optimum sensitivity setting is easy by using the teaching function with actual samples.

① Press the '0-ADJ. key' while no object exists between sensor heads.

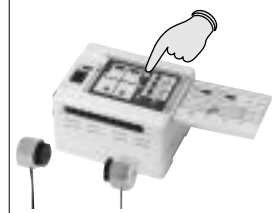

② Place one sheet between the sensor heads and press the 'SET-1 key'.

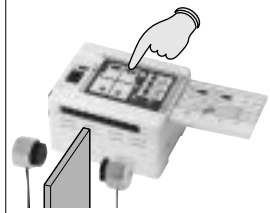

③ Place two sheets between the sensor heads and press the 'SET-2 key'.

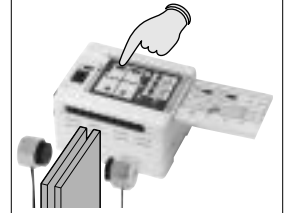

Three types of sensor heads for various objects

Small object detection sensor head / GD-3

This is an extremely small sensor head, only $\phi 3.8 \times 15$ mm $\phi 0.150 \times 0.591$ in, suitable for detecting small components.

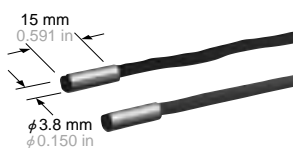

High precision sensor head / GD-10

It is suitable for high precision detection of double feeds of lead frames or thin metal sheets.

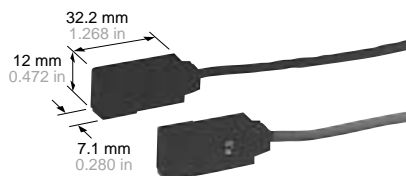

Long sensing range sensor head / GD-20

It achieves a long sensing range of 70 mm 2.756 in. Further, it employs a robust metal case with IP67 protection to withstand harsh environment.

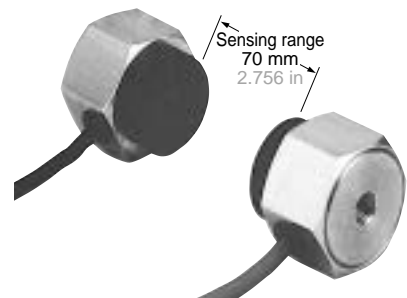

APPLICATIONS

Detecting overlap of washers

GD-3 reliably detects an overlap of small components such as washers.

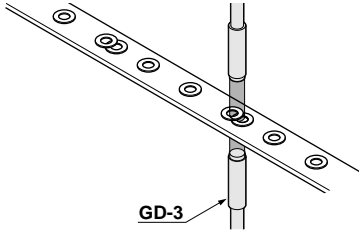

Detecting seam of hoop material

Even a minute difference in thickness can be detected.

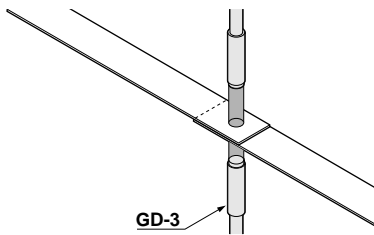

Detecting double feeds of lead frames

The high precision sensor head **GD-10** never misses double feeds of lead frames even if they are very thin and highly perforated.

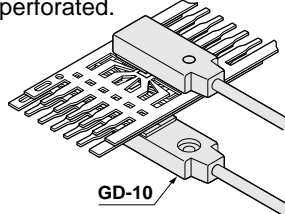

Detecting double feeds of aluminum foils

GD-10 can reliably detect double feeds of thin aluminum foils which are tens of micron thick.

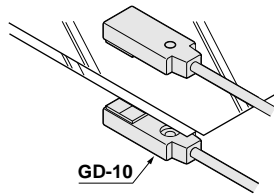

Detecting double feeds of sheet metal

The long sensing range sensor head **GD-20** allows the object thickness to be as much as 10 mm 0.394 in. Hence, various objects can be detected.

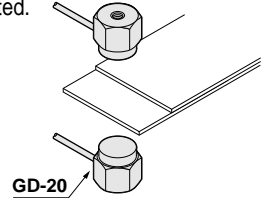

Detecting missing tablet package in box

GD-20 can check if each box contains a given number of aluminum tablet packages.

Since **GD-20** has a sensing range of up to 70 mm 2.756 in, thick boxes can pass through the sensor heads.

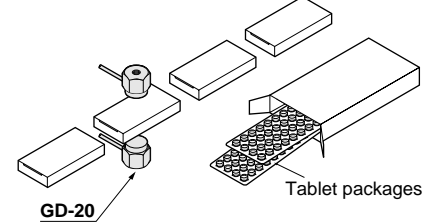

Seven LEDs indicate the sensing level

The optimum sensing point can be confirmed at a glance as seven LEDs indicate the sensing level.

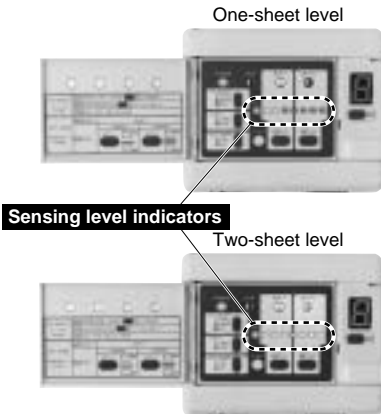

Suitable for flexible manufacturing 8 Channel memory plus RS-232C communication

Since sensitivities of eight channels can be stored, product changeover is smooth and easy.

Select channel number by the 'Channel shift key' on the operation panel or by using external channel select inputs.

Further, since **GD-C2** is equipped with **RS-232C** communication function, the sensitivity values can be stored in a personal computer, etc., and fed into the controller as per requirement.

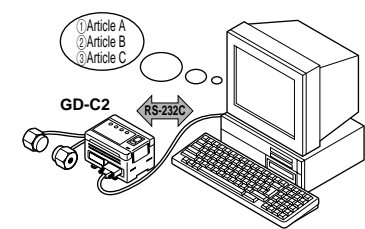
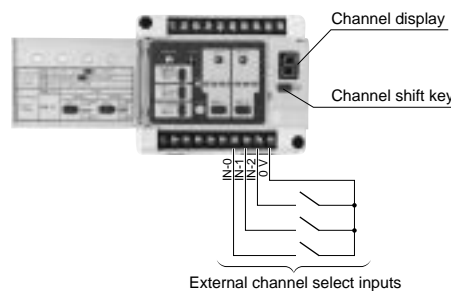

External initialization

Teaching is possible by external devices, such as, PLC, etc. This enhances productivity by machine automation.

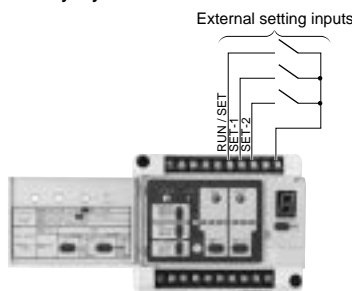

Self-diagnosis (Alarm)

The **GD** series diagnoses itself for seven items, such as, internal circuit failure, cable disconnection, etc. The result is communicated via the self-diagnosis output and displayed by the self-diagnosis indicator. Further, the type of error can be checked from the error code displayed on the channel display.

Two-sheet threshold level shift function

The two-sheet threshold level set by teaching can be shifted in nine steps to suit the detection conditions. This enables very stable detection.

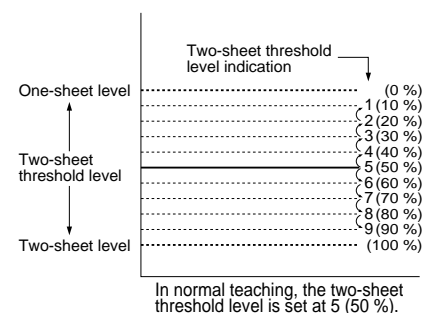

ORDER GUIDE

Sensor heads

Type	Appearance	Sensing range (between sensor heads)	Detectable sheet thickness	Model No.	Applicable controllers																																									
Small object detection		10 mm 0.394 in	Standard sensing object size: 20 X 20 mm 0.787 X 0.787 in <table border="1"> <thead> <tr> <th>Material</th> <th>Setting distance</th> <th>5 mm 0.197 in</th> <th>10 mm 0.394 in</th> </tr> </thead> <tbody> <tr> <td>Iron (SPCC)</td> <td></td> <td>0.01 to 0.1 mm 0.0004 to 0.004 in</td> <td>0.03 to 0.1 mm 0.001 to 0.004 in</td> </tr> <tr> <td>Aluminum</td> <td></td> <td>0.015 to 1 mm 0.001 to 0.039 in</td> <td>0.015 to 1 mm 0.001 to 0.039 in</td> </tr> <tr> <td>Copper</td> <td></td> <td>0.018 to 1 mm 0.001 to 0.039 in</td> <td>0.018 to 0.3 mm 0.001 to 0.012 in</td> </tr> <tr> <td>Brass</td> <td></td> <td>0.03 to 1 mm 0.001 to 0.039 in</td> <td>0.03 to 0.5 mm 0.001 to 0.020 in</td> </tr> <tr> <td>Stainless steel (SUS304)</td> <td></td> <td>0.3 to 1 mm 0.012 to 0.039 in</td> <td>0.3 to 1 mm 0.012 to 0.039 in</td> </tr> </tbody> </table>	Material	Setting distance	5 mm 0.197 in	10 mm 0.394 in	Iron (SPCC)		0.01 to 0.1 mm 0.0004 to 0.004 in	0.03 to 0.1 mm 0.001 to 0.004 in	Aluminum		0.015 to 1 mm 0.001 to 0.039 in	0.015 to 1 mm 0.001 to 0.039 in	Copper		0.018 to 1 mm 0.001 to 0.039 in	0.018 to 0.3 mm 0.001 to 0.012 in	Brass		0.03 to 1 mm 0.001 to 0.039 in	0.03 to 0.5 mm 0.001 to 0.020 in	Stainless steel (SUS304)		0.3 to 1 mm 0.012 to 0.039 in	0.3 to 1 mm 0.012 to 0.039 in	GD-3	GD-C3																	
Material	Setting distance	5 mm 0.197 in	10 mm 0.394 in																																											
Iron (SPCC)		0.01 to 0.1 mm 0.0004 to 0.004 in	0.03 to 0.1 mm 0.001 to 0.004 in																																											
Aluminum		0.015 to 1 mm 0.001 to 0.039 in	0.015 to 1 mm 0.001 to 0.039 in																																											
Copper		0.018 to 1 mm 0.001 to 0.039 in	0.018 to 0.3 mm 0.001 to 0.012 in																																											
Brass		0.03 to 1 mm 0.001 to 0.039 in	0.03 to 0.5 mm 0.001 to 0.020 in																																											
Stainless steel (SUS304)		0.3 to 1 mm 0.012 to 0.039 in	0.3 to 1 mm 0.012 to 0.039 in																																											
High precision		30 mm 1.181 in	Standard sensing object size: 80 X 80 mm 3.150 X 3.150 in <table border="1"> <thead> <tr> <th rowspan="2">Material</th> <th colspan="2">Setting distance</th> <th rowspan="2">Applicable controllers</th> </tr> <tr> <th>20 mm 0.787 in</th> <th>30 mm 1.181 in</th> </tr> </thead> <tbody> <tr> <td rowspan="2">Iron (SPCC)</td> <td>GD-C1/C2</td> <td>0.07 to 1 mm 0.003 to 0.039 in</td> <td>0.07 to 0.5 mm 0.003 to 0.020 in</td> </tr> <tr> <td>GD-C3</td> <td>0.01 to 0.3 mm 0.0004 to 0.012 in</td> <td>0.01 to 0.1 mm 0.0004 to 0.004 in</td> </tr> <tr> <td rowspan="2">Aluminum</td> <td>GD-C1/C2</td> <td>0.03 to 6 mm 0.001 to 0.236 in</td> <td>0.03 to 2 mm 0.001 to 0.079 in</td> </tr> <tr> <td>GD-C3</td> <td>0.015 to 1 mm 0.001 to 0.039 in</td> <td>0.015 to 1 mm 0.001 to 0.039 in</td> </tr> <tr> <td rowspan="2">Copper</td> <td>GD-C1/C2</td> <td>0.03 to 6 mm 0.001 to 0.236 in</td> <td>0.03 to 2 mm 0.001 to 0.079 in</td> </tr> <tr> <td>GD-C3</td> <td>0.018 to 1 mm 0.001 to 0.039 in</td> <td>0.018 to 1 mm 0.001 to 0.039 in</td> </tr> <tr> <td rowspan="2">Brass</td> <td>GD-C1/C2</td> <td>0.03 to 6 mm 0.001 to 0.236 in</td> <td>0.03 to 2 mm 0.001 to 0.079 in</td> </tr> <tr> <td>GD-C3</td> <td>0.01 to 1 mm 0.0004 to 0.039 in</td> <td>0.01 to 1 mm 0.0004 to 0.039 in</td> </tr> <tr> <td rowspan="2">Stainless steel (SUS304)</td> <td>GD-C1/C2</td> <td>0.1 to 6 mm 0.004 to 0.236 in</td> <td>0.1 to 2 mm 0.004 to 0.079 in</td> </tr> <tr> <td>GD-C3</td> <td>0.05 to 2 mm 0.002 to 0.079 in</td> <td>0.05 to 1 mm 0.002 to 0.039 in</td> </tr> </tbody> </table>	Material	Setting distance		Applicable controllers	20 mm 0.787 in	30 mm 1.181 in	Iron (SPCC)	GD-C1/C2	0.07 to 1 mm 0.003 to 0.039 in	0.07 to 0.5 mm 0.003 to 0.020 in	GD-C3	0.01 to 0.3 mm 0.0004 to 0.012 in	0.01 to 0.1 mm 0.0004 to 0.004 in	Aluminum	GD-C1/C2	0.03 to 6 mm 0.001 to 0.236 in	0.03 to 2 mm 0.001 to 0.079 in	GD-C3	0.015 to 1 mm 0.001 to 0.039 in	0.015 to 1 mm 0.001 to 0.039 in	Copper	GD-C1/C2	0.03 to 6 mm 0.001 to 0.236 in	0.03 to 2 mm 0.001 to 0.079 in	GD-C3	0.018 to 1 mm 0.001 to 0.039 in	0.018 to 1 mm 0.001 to 0.039 in	Brass	GD-C1/C2	0.03 to 6 mm 0.001 to 0.236 in	0.03 to 2 mm 0.001 to 0.079 in	GD-C3	0.01 to 1 mm 0.0004 to 0.039 in	0.01 to 1 mm 0.0004 to 0.039 in	Stainless steel (SUS304)	GD-C1/C2	0.1 to 6 mm 0.004 to 0.236 in	0.1 to 2 mm 0.004 to 0.079 in	GD-C3	0.05 to 2 mm 0.002 to 0.079 in	0.05 to 1 mm 0.002 to 0.039 in	GD-10	GD-C1 GD-C2 GD-C3
Material	Setting distance		Applicable controllers																																											
	20 mm 0.787 in	30 mm 1.181 in																																												
Iron (SPCC)	GD-C1/C2	0.07 to 1 mm 0.003 to 0.039 in	0.07 to 0.5 mm 0.003 to 0.020 in																																											
	GD-C3	0.01 to 0.3 mm 0.0004 to 0.012 in	0.01 to 0.1 mm 0.0004 to 0.004 in																																											
Aluminum	GD-C1/C2	0.03 to 6 mm 0.001 to 0.236 in	0.03 to 2 mm 0.001 to 0.079 in																																											
	GD-C3	0.015 to 1 mm 0.001 to 0.039 in	0.015 to 1 mm 0.001 to 0.039 in																																											
Copper	GD-C1/C2	0.03 to 6 mm 0.001 to 0.236 in	0.03 to 2 mm 0.001 to 0.079 in																																											
	GD-C3	0.018 to 1 mm 0.001 to 0.039 in	0.018 to 1 mm 0.001 to 0.039 in																																											
Brass	GD-C1/C2	0.03 to 6 mm 0.001 to 0.236 in	0.03 to 2 mm 0.001 to 0.079 in																																											
	GD-C3	0.01 to 1 mm 0.0004 to 0.039 in	0.01 to 1 mm 0.0004 to 0.039 in																																											
Stainless steel (SUS304)	GD-C1/C2	0.1 to 6 mm 0.004 to 0.236 in	0.1 to 2 mm 0.004 to 0.079 in																																											
	GD-C3	0.05 to 2 mm 0.002 to 0.079 in	0.05 to 1 mm 0.002 to 0.039 in																																											
Long sensing range		70 mm 2.756 in	Standard sensing object size: 200 X 200 mm 7.874 X 7.874 in <table border="1"> <thead> <tr> <th>Material</th> <th>Setting distance</th> <th>35 mm 1.378 in</th> <th>70 mm 2.756 in</th> </tr> </thead> <tbody> <tr> <td>Iron (SPCC)</td> <td></td> <td>0.07 to 10 mm 0.003 to 0.394 in</td> <td>0.07 to 6 mm 0.003 to 0.236 in</td> </tr> <tr> <td>Aluminum</td> <td></td> <td>0.03 to 10 mm 0.001 to 0.394 in</td> <td>0.03 to 6 mm 0.001 to 0.236 in</td> </tr> <tr> <td>Copper</td> <td></td> <td>0.03 to 10 mm 0.001 to 0.394 in</td> <td>0.03 to 6 mm 0.001 to 0.236 in</td> </tr> <tr> <td>Brass</td> <td></td> <td>0.03 to 10 mm 0.001 to 0.394 in</td> <td>0.03 to 6 mm 0.001 to 0.236 in</td> </tr> <tr> <td>Stainless steel (SUS304)</td> <td></td> <td>0.1 to 10 mm 0.004 to 0.394 in</td> <td>0.1 to 6 mm 0.004 to 0.236 in</td> </tr> </tbody> </table>	Material	Setting distance	35 mm 1.378 in	70 mm 2.756 in	Iron (SPCC)		0.07 to 10 mm 0.003 to 0.394 in	0.07 to 6 mm 0.003 to 0.236 in	Aluminum		0.03 to 10 mm 0.001 to 0.394 in	0.03 to 6 mm 0.001 to 0.236 in	Copper		0.03 to 10 mm 0.001 to 0.394 in	0.03 to 6 mm 0.001 to 0.236 in	Brass		0.03 to 10 mm 0.001 to 0.394 in	0.03 to 6 mm 0.001 to 0.236 in	Stainless steel (SUS304)		0.1 to 10 mm 0.004 to 0.394 in	0.1 to 6 mm 0.004 to 0.236 in	GD-20	GD-C1 GD-C2																	
Material	Setting distance	35 mm 1.378 in	70 mm 2.756 in																																											
Iron (SPCC)		0.07 to 10 mm 0.003 to 0.394 in	0.07 to 6 mm 0.003 to 0.236 in																																											
Aluminum		0.03 to 10 mm 0.001 to 0.394 in	0.03 to 6 mm 0.001 to 0.236 in																																											
Copper		0.03 to 10 mm 0.001 to 0.394 in	0.03 to 6 mm 0.001 to 0.236 in																																											
Brass		0.03 to 10 mm 0.001 to 0.394 in	0.03 to 6 mm 0.001 to 0.236 in																																											
Stainless steel (SUS304)		0.1 to 10 mm 0.004 to 0.394 in	0.1 to 6 mm 0.004 to 0.236 in																																											

Note: Only the combinations between the sensor heads and the controllers described in the above table are allowed. Any other combination may damage the connected sensor heads.

10 m 32.808 ft cable length type and 20 m 65.617 ft cable length type

10 m 32.808 ft cable length type and 20 m 65.617 ft cable length type for GD-20 are also available (Standard: 3 m 9.843 ft)

Type	Standard	10 m 32.808 ft cable length type	20 m 65.617 ft cable length type
Long sensing range	GD-20	GD-20-C10	GD-20-C20

Controllers

Type	Appearance	Model No.	Output
Standard		GD-C1	NPN open-collector transistor
With RS-232C		GD-C2	
Small object detection		GD-C3	

Make sure to use the sensor heads and the controller together in the above combinations.

SPECIFICATIONS

Sensor heads

Type		Small object detection	High precision		Long sensing range			
Item	Model No.	GD-3	GD-10		GD-20			
Applicable controllers		GD-C3	GD-C1, GD-C2 or GD-C3		GD-C1 or GD-C2			
Sensing range (between sensor heads)		10 mm 0.394 in or less		30 mm 1.181 in or less		70 mm 2.756 in or less		
Detectable sheet thickness (Note)		Standard sensing object size: 20 X 20 mm 0.787 X 0.787 in		Standard sensing object size: 80 X 80 mm 3.150 X 3.150 in		Standard sensing object size: 200 X 200 mm 7.874 X 7.874 in		
Material	Setting distance	5 mm 0.197 in	10 mm 0.394 in	20 mm 0.787 in	30 mm 1.181 in	35 mm 1.378 in	70 mm 2.756 in	
	Applicable controllers	GD-C1/C2		GD-C3		GD-C1 or GD-C2		
	Iron (SPCC)	0.01 to 0.1 mm 0.0004 to 0.004 in	0.03 to 0.1 mm 0.001 to 0.004 in	0.07 to 1 mm 0.003 to 0.039 in	0.07 to 0.5 mm 0.003 to 0.020 in	0.07 to 10 mm 0.003 to 0.394 in	0.07 to 6 mm 0.003 to 0.236 in	
	Aluminum	GD-C1/C2	0.03 to 0.1 mm 0.001 to 0.004 in		0.01 to 0.3 mm 0.0004 to 0.012 in	0.01 to 1 mm 0.0004 to 0.004 in	0.03 to 10 mm 0.001 to 0.394 in	
		GD-C3	0.015 to 1 mm 0.001 to 0.039 in	0.015 to 1 mm 0.001 to 0.039 in	0.03 to 6 mm 0.001 to 0.236 in	0.03 to 2 mm 0.001 to 0.079 in	0.03 to 10 mm 0.001 to 0.394 in	0.03 to 6 mm 0.001 to 0.236 in
	Copper	GD-C1/C2	0.015 to 1 mm 0.001 to 0.039 in		0.015 to 1 mm 0.001 to 0.039 in	0.015 to 1 mm 0.001 to 0.039 in	0.03 to 10 mm 0.001 to 0.394 in	
		GD-C3	0.018 to 1 mm 0.001 to 0.039 in	0.018 to 0.3 mm 0.001 to 0.012 in	0.03 to 6 mm 0.001 to 0.236 in	0.03 to 2 mm 0.001 to 0.079 in	0.03 to 10 mm 0.001 to 0.394 in	0.03 to 6 mm 0.001 to 0.236 in
	Brass	GD-C1/C2	0.018 to 1 mm 0.001 to 0.039 in		0.018 to 1 mm 0.001 to 0.039 in	0.018 to 1 mm 0.001 to 0.039 in	0.03 to 10 mm 0.001 to 0.394 in	
		GD-C3	0.03 to 1 mm 0.001 to 0.039 in	0.03 to 0.5 mm 0.001 to 0.020 in	0.03 to 6 mm 0.001 to 0.236 in	0.03 to 2 mm 0.001 to 0.079 in	0.03 to 10 mm 0.001 to 0.394 in	0.03 to 6 mm 0.001 to 0.236 in
	Stainless steel (SUS304)	GD-C1/C2	0.03 to 1 mm 0.001 to 0.039 in		0.03 to 1 mm 0.0004 to 0.039 in	0.01 to 1 mm 0.0004 to 0.039 in	0.1 to 10 mm 0.004 to 0.394 in	
GD-C3		0.3 to 1 mm 0.012 to 0.039 in	0.3 to 1 mm 0.012 to 0.039 in	0.1 to 6 mm 0.004 to 0.236 in	0.1 to 2 mm 0.004 to 0.079 in	0.1 to 10 mm 0.004 to 0.394 in	0.1 to 6 mm 0.004 to 0.236 in	
Environmental resistance	Protection	IP67 (IEC)				IP67 (IEC), IP67 g (JEM)		
	Ambient temperature	- 10 to + 60 °C + 14 to + 140 °F, Storage: - 25 to + 70 °C - 13 to + 158 °F						
	Ambient humidity	45 to 85 % RH, Storage: 35 to 95 % RH						
	Vibration resistance	10 to 55 Hz frequency, 1.5 mm 0.059 in amplitude in X, Y and Z directions for two hours each						
Shock resistance	1,000 m/s ² acceleration (100 G approx.) in X, Y and Z directions for three times each							
Material	Enclosure: Stainless steel (SUS 303), Sensing face: ABS		Enclosure: Polyallylate		Sensing face: Polyacetal, Main body: Stainless steel			
Cable	Sender: 0.3 mm ² single core shielded cable, 3 m 9.843 ft long Receiver: 0.1 mm ² 2-core shielded cable, 3 m 9.843 ft long				Sender: 0.5 mm ² single core shielded cable, 3 m 9.843 ft long Receiver: 0.3 mm ² 2-core shielded cable, 3 m 9.843 ft long			
Cable extension	Extension up to total 20 m 65.617 ft is possible with an equivalent shielded cable.							
Weight	90 g approx.		80 g approx.		440 g approx.			
Accessory	Sensor head mounting bracket: 1 set for sender and receiver							

Note: The above detectable sheet thicknesses are typical data at the given sensing distance. The allowable thickness will differ from the range described in the above table at other setting distances. Further, double feeds of aluminum foils can also be detected at distances shorter than the above. Please contact our office for details.

Controllers

Type		Standard	With RS-232C communication function	Small object detection
Item	Model No.	GD-C1	GD-C2	GD-C3
Supply voltage		12 to 24 V DC ± 10 % Ripple P-P 10 % or less		
Current consumption		12 V DC: 700 mA or less, 24 V DC: 400 mA or less		
Output (OUT-1, OUT-2, ALM.) (Answer-back)		NPN open-collector transistor • Maximum sink current: 100 mA • Applied voltage: 30 V DC or less (between output and 0 V) • Residual voltage: 1 V or less (at 100 mA sink current) 0.4 V or less (at 16 mA sink current)		
Output Operation	OUT-1	OFF above the one-sheet threshold level		
	OUT-2	OFF above the two-sheet threshold level		
	ALM.	OFF when an error occurs		
	Answer-back (ANS. OUT)	Refer to the time chart of the 'Sensitivity setting' on p.643.		
Short-circuit protection		Incorporated		
Response time		Automatically selected either 5 ms or less, or 30 ms or less, depending on the object	5 ms or less	
Set level storage function		Set values of eight channels stored		
Set level teaching function		Incorporated		
External setting function		Incorporated		
Indicators	Power	Green LED (lights up when the power is ON)		
	Self-diagnosis (ALM.)	Red LED (lights up during SET mode and when an error occurs during RUN mode)		
	Sensing mode (SENSE)	2-color indicator (lights up green during normal sensing mode, but yellow during precise sensing mode)		
	OUT-1	Green LED (lights up when OUT-1 is OFF, and blinks twice on completion of 0-ADJ. or SET-1 setting in SET mode)		
	OUT-2	Red LED (lights up when OUT-2 is OFF, and blinks twice on completion of 0-ADJ. or SET-2 setting in SET mode)		
Sensing level		Yellow LED × 1 and green LED × 6 (indicate the sensing level)		
Timer function		Approx. 50 ms fixed delay timer (switchable either effective or ineffective)		
Environmental resistance	Ambient temperature	- 10 to + 50 °C + 14 to + 122 °F (No dew condensation or icing allowed), Storage: - 25 to + 70°C - 13 to + 158 °F		
	Ambient humidity	45 to 85 % RH, Storage: 35 to 90 % RH		
	Noise immunity	Power line: 240 Vp, 10 ms cycle, and 0.5 μs pulse width (with noise simulator)		
	Voltage withstandability	1,000 V AC for one min. between all supply terminals connected together and enclosure		
	Insulation resistance	50 MΩ, or more, with 250 V DC megger between all supply terminals connected together and enclosure		
Vibration resistance	10 to 55 Hz frequency, 0.75 mm amplitude in X, Y and Z directions for two hours each			
Shock resistance	300 m/s ² acceleration (approx. 30 G) in X, Y and Z directions for three times each			
Material		Heat-resistant ABS		
Weight		440 g approx.		
Accessory		Insulation plate: 2 pcs.		

I/O CIRCUIT AND WIRING DIAGRAMS

Wiring diagram

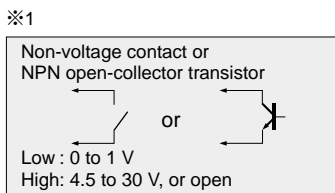
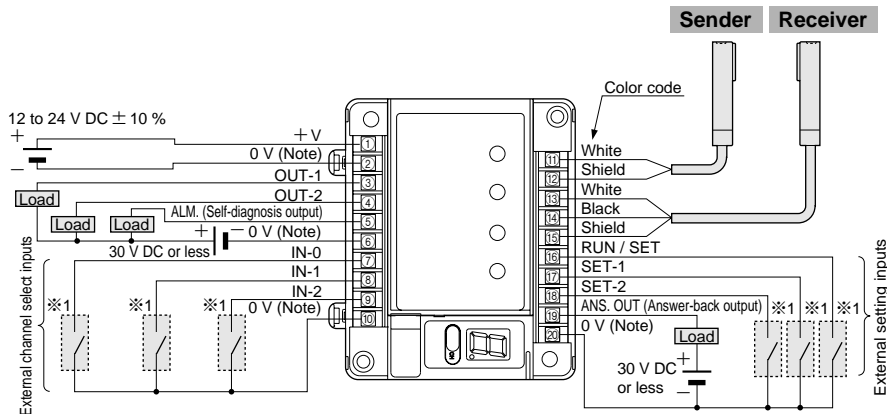

Note: Terminal ②, 0 V of power supply, is isolated from 0 V of input / output circuitry for noise immunity. However, if you expect to share the power supply with the output loads, connect terminals ② and ⑩, terminals ② and ⑩, or terminals ② and ⑳ to make 0 V common.

I/O circuit diagram

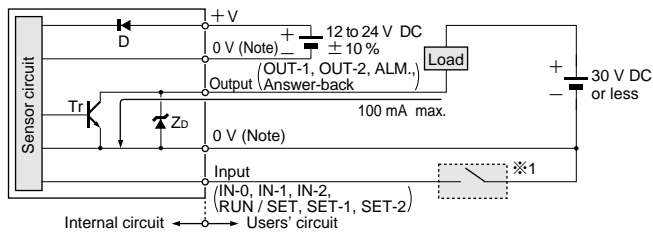

Note: 0 V of power supply is isolated from 0 V of input / output circuitry. To share the power supply with a load, both the 0 V terminals should be short-circuited.

Symbols ... D : Reverse supply polarity protection diode
Zd: Surge absorption zener diode
Tr: NPN output transistor

External channel select truth table

Channel No. \ Input	IN-0	IN-1	IN-2
1	L	H	H
2	H	L	H
3	L	L	H
4	H	H	L
5	L	H	L
6	H	L	L
7	L	L	L
8	H	H	H

L: Low (0 to 1 V), H: High (4.5 to 30 V, or open)

RS-232C wiring diagram (GD-C2 only)

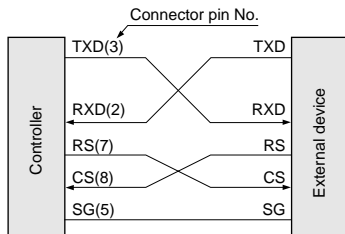

TXD: Transmit data, command
RXD: Receive data, command
RS : Request-to-send
CS : Clear-to-send
SG : Signal ground

Pin arrangement

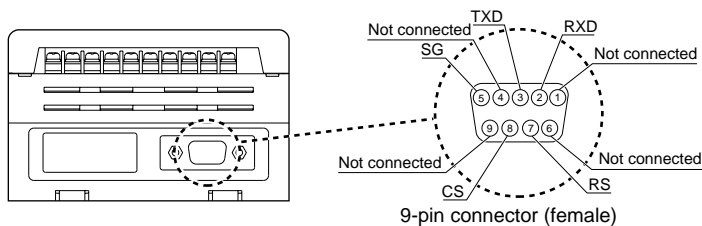

PRECAUTIONS FOR PROPER USE



• This product is not a safety sensor. Its use is not intended or designed to protect life and prevent body injury or property damage from dangerous parts of machinery. It is a normal object detection sensor.

• Make sure to use the sensor heads and controllers in the specified combinations. If they are used in any other combination, the sensor heads may get damaged.

Functional description

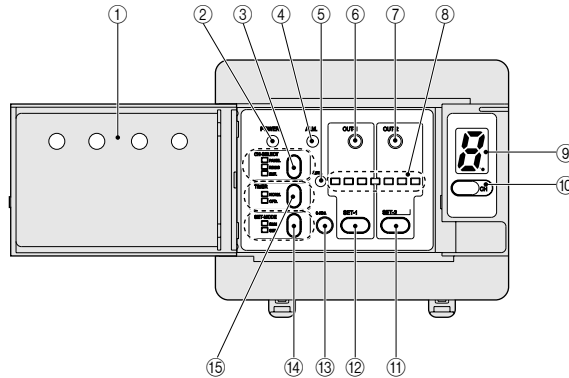

Description	Function																																																											
① Panel cover																																																												
② Power indicator (Green LED)	Lights up when the power is ON.																																																											
③ CH-SELECT key	<p>Specifies whether channel selection is by panel operation, by external channel select inputs, or through RS-232C communication.</p> <p><input type="checkbox"/> PANEL: Selection is by ⑩ channel select key.</p> <p><input type="checkbox"/> LOCK: Locks channel selection. In case of GD-C2, this (GD-C2) is also the setting for channel selection by RS232C external device through RS-232C.</p> <p><input type="checkbox"/> EXT.: Selection is by external channel select inputs.</p> <p>The table below gives the key and external input operation for each channel selection method. ○: Operable</p> <table border="1"> <thead> <tr> <th rowspan="2">Operation</th> <th colspan="3">Mode</th> </tr> <tr> <th>PANEL</th> <th>LOCK (RS-232C)</th> <th>EXT.</th> </tr> </thead> <tbody> <tr> <td rowspan="5">Panel keys</td> <td>RUN / SET selection</td> <td>○ (Note)</td> <td>○ (Note)</td> <td>○ (Note)</td> </tr> <tr> <td>Timer mode selection</td> <td>○</td> <td>○</td> <td>○</td> </tr> <tr> <td>SET-1</td> <td>○</td> <td>○</td> <td>○</td> </tr> <tr> <td>SET-2</td> <td>○</td> <td>○</td> <td>○</td> </tr> <tr> <td>0-ADJ.</td> <td>○</td> <td>○</td> <td>○</td> </tr> <tr> <td rowspan="5">External inputs</td> <td>Channel shift</td> <td>○</td> <td></td> <td></td> </tr> <tr> <td>RUN / SET</td> <td>○</td> <td>○</td> <td>○</td> </tr> <tr> <td>SET-1</td> <td>○</td> <td>○</td> <td>○</td> </tr> <tr> <td>SET-2</td> <td>○</td> <td>○</td> <td>○</td> </tr> <tr> <td>IN-0</td> <td></td> <td></td> <td>○</td> </tr> <tr> <td></td> <td>IN-1</td> <td></td> <td></td> <td>○</td> </tr> <tr> <td></td> <td>IN-2</td> <td></td> <td></td> <td>○</td> </tr> </tbody> </table> <p>Note: The RUN / SET selection with the SET-MODE key on the panel is effective only when the RUN / SET selection input is High (RUN mode).</p>	Operation	Mode			PANEL	LOCK (RS-232C)	EXT.	Panel keys	RUN / SET selection	○ (Note)	○ (Note)	○ (Note)	Timer mode selection	○	○	○	SET-1	○	○	○	SET-2	○	○	○	0-ADJ.	○	○	○	External inputs	Channel shift	○			RUN / SET	○	○	○	SET-1	○	○	○	SET-2	○	○	○	IN-0			○		IN-1			○		IN-2			○
Operation	Mode																																																											
	PANEL	LOCK (RS-232C)	EXT.																																																									
Panel keys	RUN / SET selection	○ (Note)	○ (Note)	○ (Note)																																																								
	Timer mode selection	○	○	○																																																								
	SET-1	○	○	○																																																								
	SET-2	○	○	○																																																								
	0-ADJ.	○	○	○																																																								
External inputs	Channel shift	○																																																										
	RUN / SET	○	○	○																																																								
	SET-1	○	○	○																																																								
	SET-2	○	○	○																																																								
	IN-0			○																																																								
	IN-1			○																																																								
	IN-2			○																																																								
④ Self-diagnosis indicator (Red LED)	Set mode : Lights up under normal condition Run mode: Lights up on error																																																											

Description	Function
⑤ Sensing mode indicator (2-color LED)	Indicates the sensing mode. · Lights up green : Normal sensing mode (Refer to 'Sensing mode' on p.643.) · Lights up yellow: Precise sensing mode
⑥ OUT-1 indicator (Green LED)	· Lights up when OUT-1 is OFF. · Blinks twice on completion of 0-ADJ. or SET-1 setting in SET mode.
⑦ OUT-2 indicator (Red LED)	· Lights up when OUT-2 is OFF. · Blinks twice on completion of 0-ADJ. or SET-2 setting in SET mode.
⑧ Sensing level indicator (Yellow LED X 1, Green LED X 6)	Seven LEDs show the sensing level. · More the number, thicker, or larger the object sheets are, more are the LEDs which light up. LEDs blink one after the other during teaching. All LEDs blink at the same time if the teaching fails.
⑨ Channel display	Shows the present channel (1 to 8). · Blinks during SET mode. · The decimal point informs whether the set level data has been stored.  Lights up: → Stored Lights off: → Not stored · When an error occurs, the display indicates the error code. Refer to 'Self-diagnosis (Alarm) function' on p.646 for more details.
⑩ Channel shift key	The channel can be selected by the channel shift key when CH-SELECT is set at PANEL.
⑪ SET-2 key	Sets the two-sheet threshold level (larger number of sheets).
⑫ SET-1 key	Sets the one-sheet threshold level (smaller number of sheets).
⑬ 0-ADJ. key	Calibrates zero level under sheet non-existing condition.
⑭ SET-MODE key	Switches between RUN mode and SET mode. <input type="checkbox"/> RUN: Detection takes place. <input type="checkbox"/> SET : Set-up is done.
⑮ TIMER key	Switches timer mode. <input type="checkbox"/> NORM. mode: Timer not used <input type="checkbox"/> OFD. mode: Delay timer (50 ms approx.) used

Wiring

- Make sure that the power supply is off while wiring.
- Verify that the supply voltage variation is within the rating.
- If power is supplied from a commercial switching regulator, ensure that its frame ground F.G. terminal is connected to an actual ground.
- In case noise generating equipment (switching regulator, induction motor, etc.) is used in the vicinity of this product, connect the frame ground (F.G.) terminal of the equipment to an actual ground.
- Do not run the wires together with high-voltage lines or power lines or put them in the same raceway. This can cause malfunction due to induction.

Others

- Do not operate the sensor for a few seconds immediately after supplying power because of transient conditions including self-diagnosis time.
- Make sure to check the ability of the sensor to detect the number of sheets of your actual objects before use. If real objects differ from teaching samples in size or in characteristics, or the detecting condition deviates, an error may occur. Please note that magnetic metals or metals with low magnetic permeability such as steel especially have a strong tendency.
- In situations when magnets are in close proximity such as during electromagnet conveyance, this causes malfunctions due to electromagnetic disorder.
- When conducting minute detections, favorable sensing conditions are obtained only after having elapsed 60 minutes after the initial introduction of the power supply.

PRECAUTIONS FOR PROPER USE

Mounting

Placing of sensor heads

- Make the sender and receiver face each other and align their sensing center line.

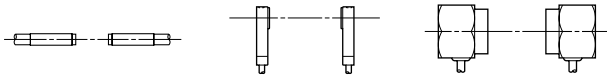

- Keep a distance from any magnet or a device generating magnetic field. It may degrade the detectability.
- Surrounding metal influences the detectability. Please contact our office for more details.
- If more than one set of sensor heads are closely mounted, detectability may be affected. Please contact our office for more details.

Mounting sensor heads

<GD-3>

Mounting with set screw

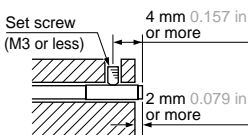

- Use a set screw (M3 or less), and the tightening torque should be 0.12 N·m or less.

<GD-10>

Fixing at one point Fixing at two points

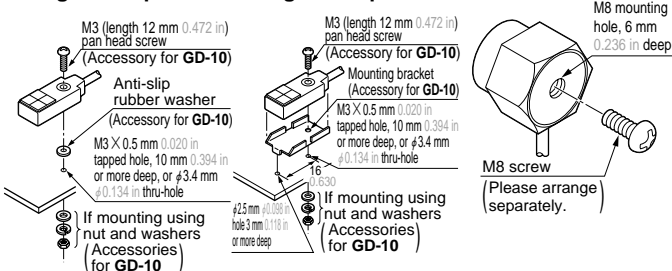

- The tightening torque should be 0.5 N·m or less.
- To mount the sensor head with a nut, the thru-hole should be $\phi 3.4$ mm $\phi 0.134$ in. (The mounting board must be 2.3 mm 0.091 in, or less, thick.)
- The tightening torque should be 11.2 N·m or less.

Mounting of controller

<On DIN rail>

- ① With the stopper pressed in the direction of the arrow (it locks), fit the front portion of the mounting section of the amplifier on the 35 mm 1.378 in width DIN rail.
 - ② Press and fit the rear portion of the mounting section on the 35 mm 1.378 in width DIN rail.
- ※To remove, insert a 'minus' screwdriver into the stopper and pull out.

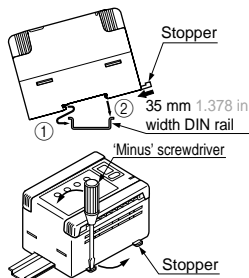

<On board with screws>

- Use two M4 pan head screws 10 mm 0.394 in, or more, long. The tightening torque should be 1.2 N·m or less.

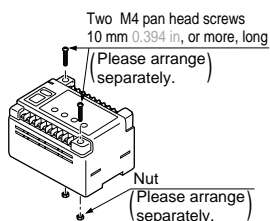

Distance from nearby metals

- As metals near the sensor head may affect the sensing performance, pay attention to the following points.

Influence of nearby metal

- The sensor head must be separated from nearby metal by a minimum distance as specified in the table below.

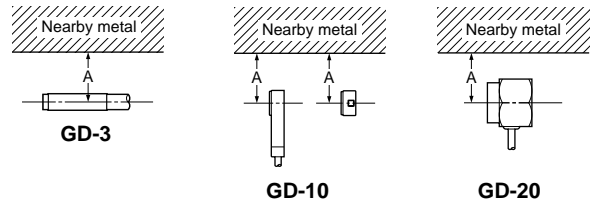

<Dimension A (in case of iron)>

Setting distance / Model No.	5 mm 0.197 in	10 mm 0.394 in	30 mm 1.181 in	70 mm 2.756 in
GD-3	15 mm 0.591 in	20 mm 0.787 in	—	—
GD-10	100 mm 3.937 in			
GD-20	100 mm 3.937 in			

Embedding in metal

- The sensing performance may be affected if the sensor is completely embedded in a metal. Keep a minimum clearance between the sensor head and the metal as specified in the table below.

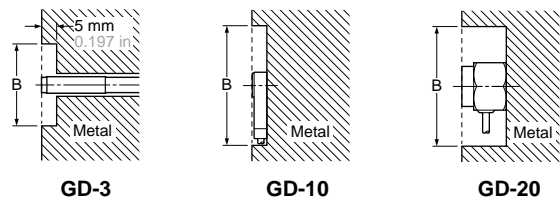

<Dimension B (in case of iron)>

Setting distance / Model No.	5 mm 0.197 in	10 mm 0.394 in	30 mm 1.181 in	70 mm 2.756 in
GD-3	$\phi 15$ mm $\phi 0.591$ in	$\phi 20$ mm $\phi 0.787$ in	—	—
GD-10	$\phi 100$ mm $\phi 3.937$ in			
GD-20	$\phi 100$ mm $\phi 3.937$ in			

PRECAUTIONS FOR PROPER USE

Interference prevention

- When two or more sensor heads are mounted in parallel, keep a minimum separation distance as specified below to avoid interference.

In case the sender and another sensor's receiver are placed adjacently



<Dimension C>

Setting distance (Note)	5 mm	10 mm	20(35) mm	30(70) mm
Model No.	0.197 in	0.394 in	0.787(1.378) in	1.181(2.756) in
GD-3	60 mm 2.362 in	80 mm 3.150 in	—	—
GD-10	160 mm 6.299 in		220 mm 8.661 in	
GD-20	370 mm 14.567 in		630 mm 24.803 in	

Note: The value in the brackets is for GD-20.

In case the respective senders and receivers are placed adjacently

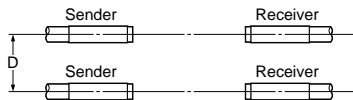

<Dimension D>

Setting distance (Note)	5 mm	10 mm	20(35) mm	30(70) mm
Model No.	0.197 in	0.394 in	0.787(1.378) in	1.181(2.756) in
GD-3	30 mm 1.181 in	50 mm 1.969 in	—	—
GD-10	200 mm 7.874 in		250 mm 9.843 in	
GD-20	450 mm 17.717 in		700 mm 27.559 in	

Note: The value in the brackets is for GD-20.

Sensing mode

- The GD series has two sensing modes, one is the normal sensing mode and the other is the precise sensing mode. They are automatically selected by the characteristics of the object.

Normal sensing mode : The GD series goes into this mode when the number of objects (e.g., large metal sheets) is distinguished with relative ease.



Iron etc.

Precise sensing mode : The GD series goes into this mode when the number of objects (e.g., lead frames) is difficult to distinguish. In this mode, the sensitivity difference is so minute between two sensing levels that vibration and temperature changes must be carefully managed.



Lead frame etc.

- The sensing mode indicator lights up green during the normal sensing mode, but lights up yellow during the precise sensing mode.

Timer function

- The GD series is incorporated with a fixed delay timer of 50 ms approx. Since the signal output is extended by a fixed time interval, this is useful when the connected device has a slow response time or when small objects are detected and the output signal width is small.

Time chart

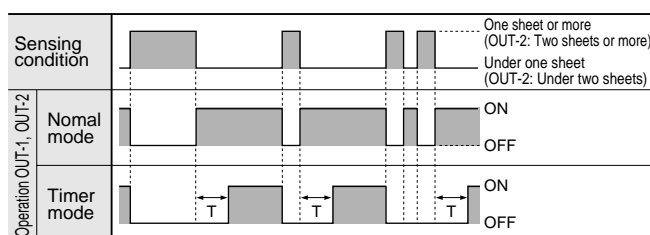

Timer period: T = 50 ms approx.

Note: Once the timer becomes effective, it acts upon both OUT-1 and OUT-2 of all channels.

Sensitivity setting

Teaching through operation panel

Procedure	Operation
Preparation	① Turn the power on. • Check that the power indicator lights up.
	② Open the panel cover.
Channel selection	③ Select 'PANEL' by pressing 'CH-SELECT key'. • This enables the keys on the panel.
	④ Select one of eight channels by pressing the 'channel shift key'. To modify a previously stored data, choose the particular channel. Otherwise, choose any channel from 1 to 8. • If the selected channel does not have data stored in it, the self-diagnosis indicator lights up.
Level setting	⑤ Enter into the SET mode from the RUN mode by pressing the 'SET-MODE key'. • The self-diagnosis indicator lights up. • The designated channel number blinks.
	⑥ (Note 1) (Note 2) Press the '0-ADJ. key' while no object exists between the sensor heads. • After the sensing level indicators light up one after the other for about four cycles, both OUT-1 and OUT-2 blink twice at the same time.
	⑦ (Note 1) Place one sheet between the sensor heads, and then press the 'SET-1 key'. • The sensing level indicators blink one after the other for about four cycles. After that, OUT-1 blinks twice. • Hold the object steadily between the sensor heads while the sensing level indicators are lighting up in rotation.
	⑧ (Note 1) Place two sheets between the sensor heads, and then press the 'SET-2 key'. • The sensing level indicators light up one after the other for about four cycles. After that, OUT-2 blinks twice. • Hold the objects steadily between the sensor heads while the sensing level indicators are lighting up in rotation.
	※ If the teaching fails, all the sensing indicators blink at the same time. In this case, repeat the sensitivity setting after changing the setting of the sender and the receiver.
	⑨ Return to the 'RUN mode' from SET mode by pressing the 'SET-MODE key'. • The self-diagnosis indicator lights off. [If it does not light off, an error may be inherent. Refer to 'Self-diagnosis (Alarm) function' on p.646.] • The indicated channel number changes from blinking into continuous lighting. • During the RUN mode, the '0-ADJ. key', 'SET-1 key', and 'SET-2 key' are ineffective.

- Notes: 1) The order of the above procedure at ⑥, ⑦ and ⑧ is arbitrary.
The 'SET-1 key' searches the one-sheet level, and the 'SET-2 key' the two-sheet level. After having selected the SET mode, only by pressing either one once, the one-sheet or two-sheet levels are not undated. After having pressed the 'SET-1' and 'SET-2' keys once in SET mode, as long as it is in SET mode, the one-sheet or the two-sheet level is updated by pressing either SET keys. The moment the RUN mode is set, the data is confirmed. (Setting complete)
- 2) The zero-sheet level is common for all eight channels. Once the zero-sheet level is set for one channel after the sensor heads are installed, there is no need to set it again for the other channels.
(However, set the one-sheet level and the two-sheet level on each channel, once again, when 0-ADJ. key is pressed since this resets the zero-sheet level as per the prevailing conditions.)
- 3) The set data is stored in an EEPROM.
However, the EEPROM has a life time which is limited to 100,000 write operation cycles.
- 4) If the setting of the sender and receiver is changed after teaching, detection may become unstable. In this case, perform the teaching once again.

PRECAUTIONS FOR PROPER USE

③ Other commands

Syntax: [Statement] + [CR (ETX)]

<Type of commands>

Statement	Usage
\$	Enter into RS-232C communication from other accesses.
RNM	Enter into panel access.
EXT.	Enter into EXT. access.
CH1 to 8	Change channel.
LOCK	Disable panel and EXT. accesses.
UNLOCK	Enable panel and EXT. accesses.
PLOCK	Disable the operation panel.
TIM 0	Enter into 'NORM. (non-timer)' timer mode.
TIM 1	Enter into 'OFD. (timer usage)' timer mode.
SMD 0	Enter into 'SET mode'.
SMD 1	Enter into 'RUN mode'.
ADJ 0	Execute zero adjust command. (Zero-sheet level teaching) • After the command execution, the following response is given depending on the teaching condition. On successful teaching: [OK] + [CR (ETX)] On unsuccessful teaching: [NG] + [CR (ETX)]
SET 1	Execute SET-1 command. (One-sheet level teaching) • After the command execution, the following response is given depending on the teaching condition. On successful teaching: [OK] + [CR (ETX)] On unsuccessful teaching: [NG] + [CR (ETX)]
SET 2	Execute SET-2 command. (Two-sheet level teaching) • After the command execution, the following response is given depending on the teaching condition. On successful teaching: [OK] + [CR (ETX)] On unsuccessful teaching: [NG] + [CR (ETX)]

After the above command is sent, [Statement] + [CR (ETX)] is returned by **GD-C2** to confirm the communication.

Notes: 1) If the sent command is ineffective, **GD-C2** returns 'Not Available'.
2) All characters including send and response statements are based on ASCII code.

Two-sheet threshold level shift function

Outline

• In normal teaching, the two-sheet threshold level is automatically set at the center of the one-sheet level and the two-sheet level. The two-sheet threshold level shift function enables you to shift the two-sheet threshold level towards, either, the one-sheet level, or, the two-sheet level, in four steps. Consequently, if either one of the detection levels is stable, then by shifting the two-sheet threshold level towards that side, stable detection is possible even if the other detection level is unstable. Further, since by shifting the two-sheet threshold level, the two-sheet threshold level, the difference between it and, either, the one-sheet level, or, the two-sheet level can be made small, fine detection is also possible.

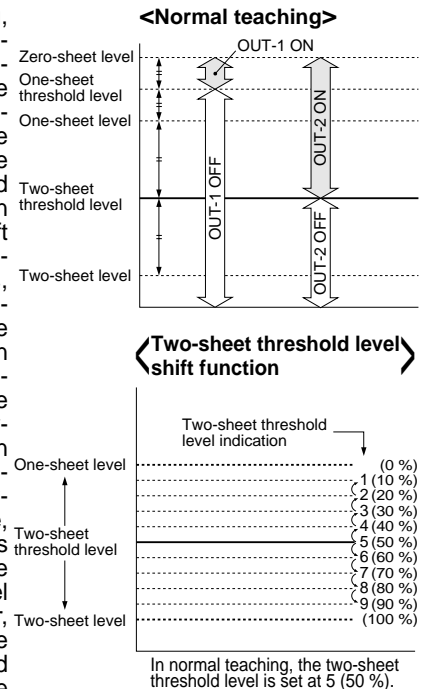

Setting Procedure

Step	Operation
①	Perform normal teaching.
②	Select 'RUN mode' by 'SET-MODE key'. <div style="float: right;"> <input checked="" type="checkbox"/> RUN ← <input type="checkbox"/> SET </div>
③	Press '0-ADJ. key' for more than 3 sec. • '●' is displayed on the channel display and the sensor enters the two-sheet threshold level shift mode. • When '0-ADJ. key' is released, the '●' display changes to a blinking display of '5', which is the two-sheet threshold level before the shift. • The self-diagnosis indicator lights up in the two-sheet threshold level shift mode. <div style="float: right;"> → ← </div>
④	Shift the two-sheet threshold level by pressing either 'SET-1 key' or 'SET-2 key'. • Each time 'SET-1 key' is pressed, the two-sheet threshold level shifts as '5' → '4' → '3' → '2' → '1', i.e., towards the one-sheet level. (It becomes easier for OUT-2 (two-sheet output) to go OFF.) • Each time 'SET-2 key' is pressed, the two-sheet threshold level shifts as '5' → '6' → '7' → '8' → '9', i.e., towards the two-sheet level. (It becomes more difficult for OUT-2 (two-sheet output) to go OFF.) <div style="float: right;"> </div>
⑤	After having shifted the two-sheet threshold level, press '0-ADJ. key' till '●' appears on the channel display. (The shifted two-sheet threshold level is stored and the sensor returns to the RUN mode.) • The self-diagnosis indicator turns off.

Caution

- Make sure to press '0-ADJ. key' after shifting the two-sheet threshold level. If 'CH-SELECT key', 'SET-MODE key' or 'CH key' is pressed, although the sensor returns to the RUN mode, the shifted two-sheet threshold level is not stored.
- With respect to a single teaching data, make sure to shift the two-sheet threshold level only once. In case you wish to shift the level once again, do so after performing the normal teaching again.

PRECAUTIONS FOR PROPER USE

Self-diagnosis (Alarm) function

- The **GD** series diagnoses itself. The result lights up the self-diagnosis indicator, generates the self-diagnosis output, and shows the error code on the channel display as per the following table.

Description	Channel display	Sensing level indicators	Self-diagnosis indicator (Note)	Self-diagnosis output (Note)	Countermeasures
On power-ON					
Internal circuit failure		Blink	Lights up	OFF	Please contact our office.
Disconnected sender cable		Blink	Lights up	OFF	Check connection of sender cable.
Operation key pressed for 30 sec. or more		Blink	Lights up	OFF	Check keys on panel.
Too little contrast between one and two sheet levels	Present channel number	—	Lights up for 1 sec.	OFF for 1 sec. (self-restoration)	Change the setting.
Selection of channel without stored data	Present channel number	—	Lights up	OFF	Select the channel in which data is stored.
Syntax error		Blink 10 times	Lights up	ON	Check RS-232C protocol (baud rate, parity, stop bits, data bits.)
Memory overflow		Blink	Lights up	ON	Check if the terminal code is correctly sent.

Note: In the SET mode, the self-diagnosis indicator continuously lights up and the self-diagnosis output stays off.

Response time

- The controllers **GD-C1** and **GD-C2** automatically select the most suitable signal processing method, according to the material and thickness of the sensing object. Depending on the selected signal processing method, the response time is also automatically determined as either '5ms or less', or '30 ms or less'. Further, when controller **GD-C3** is used, the response time is 5ms or less. The response time of the controllers, **GD-C1** and **GD-C2**, can be confirmed by the following procedure.

- Press '0-ADJ. key' in 'RUN mode'.
- The channel display shows an alphanumeric character that represents the response time as given below.

or ➔ 5 ms or less

Other than the above ➔ 30 ms or less

ALL-LOCK function

- All keys on the operation panel are locked when the channel shift key is pressed for 3 sec. or more (unless CH-SELECT is set on 'PANEL'). To release the lock, press the channel shift key for 3 sec., or more, again.

DIMENSIONS (Unit: mm in)

GD-3 Sensor head

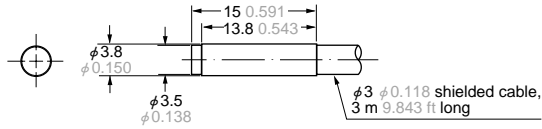

GD-10 Sensor head

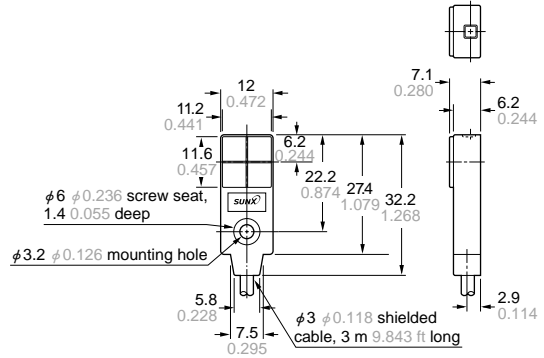

GD-20 Sensor head

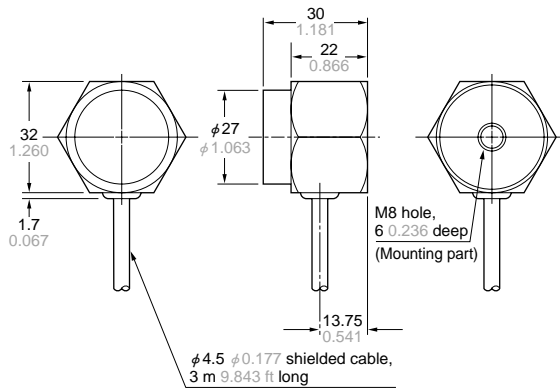

GD-C1, GD-C2, GD-C3 Controller

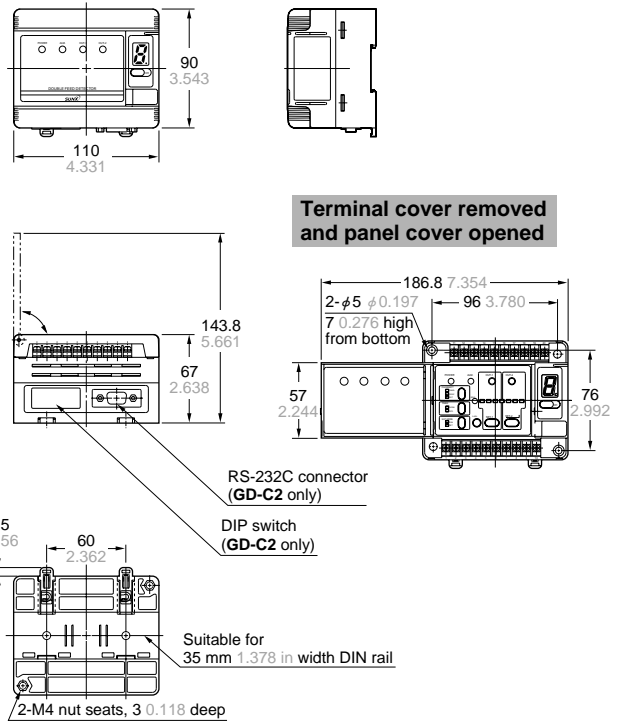

Sensor head mounting bracket set (Accessory for **GD-10**)

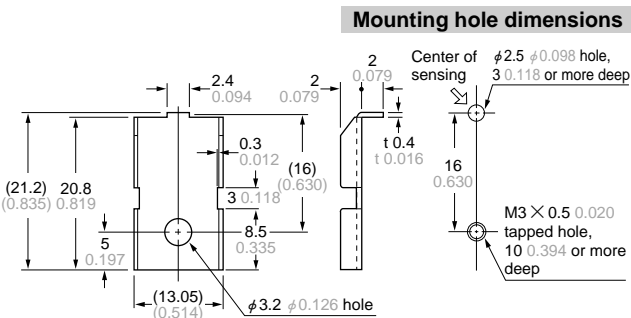

Material: Cold rolled carbon steel (SPCC)
(Nickel plated)

1 pc. each of M3 (length 12 mm 0.472 in) pan head screw, nut, plain washer, spring washer, and anti-slip rubber washer ($\phi 9.5 \times t 0.5$ mm $\phi 0.374 \times t 0.020$ in) is attached.