

GL-8/8U SERIES

Low Price & Compact Inductive Proximity Sensor **Amplifier Built-in**

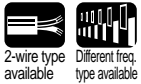

Wide variety!
Low price!



Low price

The **GL-8/8U** series satisfies the need for a low price inductive proximity sensor. It is recommended to large volume users for cost reduction.

The **GL-8/8U** series is available in units of ten sensors.

Easy handling DC 3-wire type

Compared with the DC 2-wire type, there are no restrictions to connection device input conditions when wiring.

Energy-efficient and wire-saving DC 2-wire type

Its electric current consumption is just 0.8 mA or less and the wiring workload is reduced by about 30 %.

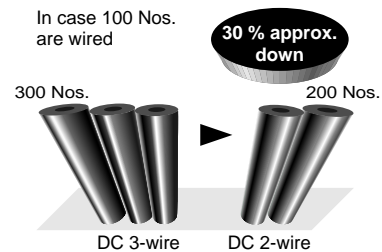

Wide variety

A wide variety of 16 types, front sensing type / top sensing type, normally open type / normally closed type, as well as, different frequency type which allows close mounting of sensors, is available.

Equipped with operation indicator

The **GL-8/8U** series is equipped with an operation indicator (orange) for operation confirmation.

Waterproof

Since the sensor has IP67 protection, it can withstand water splashes.

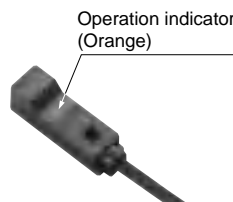
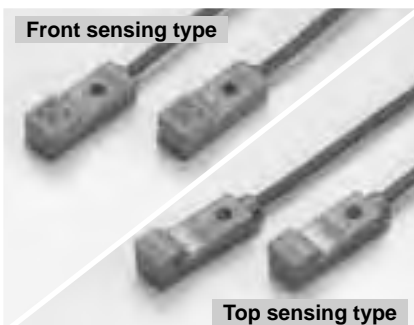

APPLICATIONS

Detecting table over-run

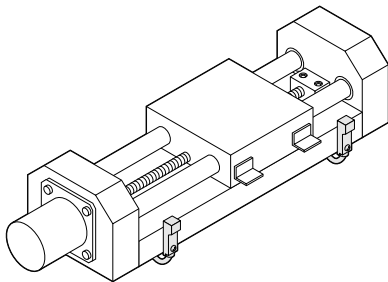

Detecting cam position

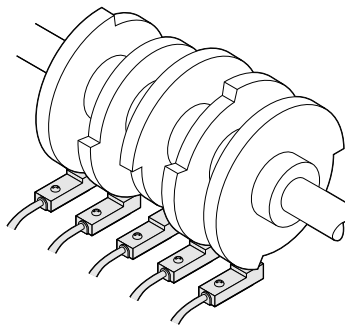

ORDER GUIDE

Type	Appearance (mm in)	Sensing range (Note 1)	Model No. (Note 2)	Output	Output operation
DC 3-wire	Front sensing 		GL-8F × 10	NPN open-collector transistor	Normally open
			GL-8FI × 10		Normally closed
			GL-8FB × 10		Normally open
	GL-8FIB × 10		Normally closed		
	GL-8H × 10		Normally open		
	GL-8HI × 10		Normally closed		
Top sensing 	GL-8HB × 10	Normally open			
	GL-8HIB × 10	Normally closed			
DC 2-wire	Front sensing 		GL-8FU × 10	Non-contact DC 2-wire type	Normally open
			GL-8FUI × 10		Normally closed
			GL-8FUB × 10		Normally open
	GL-8FUIB × 10		Normally closed		
	GL-8HU × 10		Normally open		
	GL-8HUI × 10		Normally closed		
Top sensing 	GL-8HUB × 10	Normally open			
	GL-8HUIB × 10	Normally closed			

Notes: 1) The maximum operation distance stands for the maximum distance for which the sensor can detect the standard sensing object. The stable sensing range stands for the sensing range for which the sensor can stably detect the standard sensing object even if there is an ambient temperature drift and/or supply voltage fluctuation.
2) 'I' in the model No. indicates a different frequency type.

NOTE: Low price & compact inductive proximity sensors (GL-8/8U series) are available in units of ten.

5 m 16.404 ft cable length type

5 m 16.404 ft cable length type (standard: 1 m 3.281 ft) is also available.

• Table of Model Nos.

Type	Standard	5 m 16.404 ft cable length type	
DC 3-wire	Front sensing	GL-8F × 10	GL-8F-C5 × 10
		GL-8FI × 10	GL-8FI-C5 × 10
		GL-8FB × 10	GL-8FB-C5 × 10
		GL-8FIB × 10	_____
	Top sensing	GL-8H × 10	GL-8H-C5 × 10
		GL-8HI × 10	GL-8HI-C5 × 10
		GL-8HB × 10	GL-8HB-C5 × 10
		GL-8HIB × 10	_____
DC 2-wire	Front sensing	GL-8FU × 10	GL-8FU-C5 × 10
		GL-8FUI × 10	GL-8FUI-C5 × 10
		GL-8FUB × 10	GL-8FUB-C5 × 10
		GL-8FUIB × 10	_____
	Top sensing	GL-8HU × 10	GL-8HU-C5 × 10
		GL-8HUI × 10	GL-8HUI-C5 × 10
		GL-8HUB × 10	GL-8HUB-C5 × 10
		GL-8HUIB × 10	_____

GL-8/8U

OPTION

Designation	Model No.
Sensor mounting bracket	MS-GL8 X 10

Sensor mounting bracket • MS-GL8 X 10

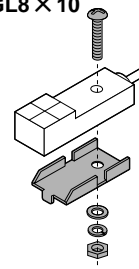

1 pc. each of M3 (length 12 mm 0.472 in) truss head screw, nut, spring washer and plain washer is attached.

NOTE: Sensor mounting bracket (MS-GL8 X 10) is available in units of ten.

SPECIFICATIONS

Item	Type	DC 3-wire type				DC 2-wire type			
		Front sensing		Top sensing		Front sensing		Top sensing	
		Model No.	GL-8F X 10	GL-8FB X 10	GL-8H X 10	GL-8HB X 10	GL-8FU X 10	GL-8FUB X 10	GL-8HU X 10
	Different frequency	GL-8FI X 10	GL-8FIB X 10	GL-8HI X 10	GL-8HIB X 10	GL-8FUI X 10	GL-8FUIB X 10	GL-8HUI X 10	GL-8HUIB X 10
Max. operation distance (Note 1)		2.5 mm 0.098 in ± 20 %							
Stable sensing range (Note 1)		0 to 1.8 mm 0 to 0.071 in							
Standard sensing object		Iron sheet 15 X 15 X t 1 mm 0.591 X 0.591 X t 0.039 in							
Hysteresis		20 % or less of operation distance							
Supply voltage		12 to 24 V DC ± 10 %							
Current consumption		15 mA or less				0.8 mA or less (Note 2)			
Output		NPN open-collector transistor • Maximum sink current: 100 mA (Note 3) • Applied voltage: 30 V DC or less (between output and 0 V) • Residual voltage: 1 V or less (at 100 mA sink current) 0.4 V or less (at 16 mA sink current)				Non-contact DC 2-wire type • Load current: 3 to 70 mA (Note 4) • Residual voltage: 3 V or less (Note 5)			
Utilization category		DC-12 or DC-13							
Output operation		Normally open	Normally closed	Normally open	Normally closed	Normally open	Normally closed	Normally open	Normally closed
Short-circuit protection		Incorporated							
Max. response frequency		1 kHz							
Operation indicator		Orange LED (lights up when the output is ON)							
Environmental resistance	Pollution degree	3 (Industrial environment)							
	Protection	IP67 (IEC)							
	Ambient temperature	- 25 to + 70 °C - 13 to + 158 °F, Storage: - 30 to + 80 °C - 22 to + 176 °F							
	Ambient humidity	35 to 95 % RH, Storage: 35 to 95 % RH							
	EMC	EN 50081-2, EN 50082-2, EN 60947-5-2							
	Voltage withstandability	1,000 V AC for one min. between all supply terminals connected together and enclosure							
	Insulation resistance	50 MΩ, or more, with 250 V DC megger between all supply terminals connected together and enclosure							
	Vibration resistance	10 to 55 Hz frequency, 1.5 mm 0.059 in amplitude in X, Y and Z directions for two hours each							
Shock resistance	1,000 m/s ² acceleration (100 G approx.) in X, Y and Z directions for three times each								
Sensing range variation	Temperature characteristics	Over ambient temperature range - 25 to + 70 °C - 13 to + 158 °F: within $\pm 15\%$ of sensing range at + 20 °C + 68 °F							
	Voltage characteristics	Within ± 2 % for ± 10 % fluctuation of the supply voltage							
Material		Enclosure: Polyallylate							
Cable		0.15 mm ² 3-core cabtyre cable, 1 m 3.281 ft long				0.15 mm ² 2-core cabtyre cable, 1 m 3.281 ft long			
Cable extension		Extension up to total 100 m 328.084 ft is possible with 0.3 mm ² , or more, cable.				Extension up to total 50 m 164.042 ft is possible with 0.3 mm ² , or more, cable.			
Weight		13 g approx.				12 g approx.			

- Notes: 1) The maximum operation distance stands for the maximum distance for which the sensor can detect the standard sensing object. The stable sensing range stands for the sensing range for which the sensor can stably detect the standard sensing object even if there is an ambient temperature drift and/or supply voltage fluctuation.
- 2) It is the leakage current when the output is in the OFF state.
- 3) When the ambient temperature is + 60 to + 70 °C + 140 to + 158 °F, the maximum sink current varies depending on the ambient humidity. Refer to 'I/O CIRCUIT AND WIRING DIAGRAMS' on p.707 for more details.
- 4) The maximum load current varies depending on the ambient temperature. Refer to 'I/O CIRCUIT AND WIRING DIAGRAMS' on p.707 for more details.
- 5) When the cable is extended, the residual voltage becomes larger according to the resistance of the cable.

I/O CIRCUIT AND WIRING DIAGRAMS

DC 3-wire type

I/O circuit diagram

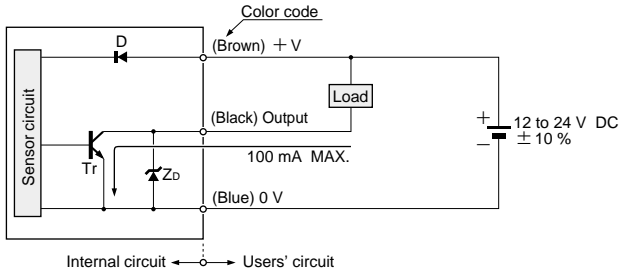

Symbols ... D : Reverse supply polarity protection diode
 Zb: Surge absorption zener diode
 Tr : NPN output transistor

Note: When the ambient temperature is +60 °C to +70 °C +140 °F to +158 °F, the maximum sink current varies depending on the ambient humidity.

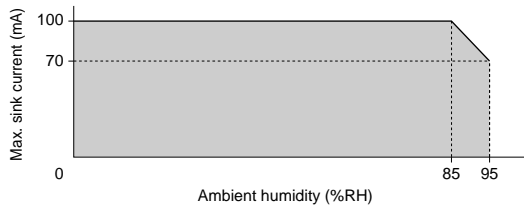

Wiring diagram

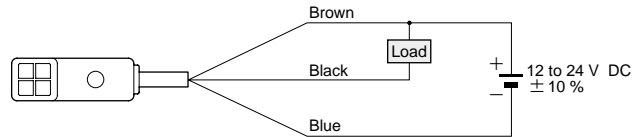

DC 2-wire type

I/O circuit diagram

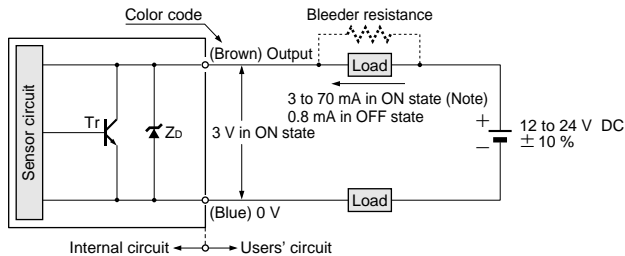

Symbols ... Zb: Surge absorption zener diode
 Tr : NPN output transistor

Note: The maximum load current varies depending on the ambient temperature.

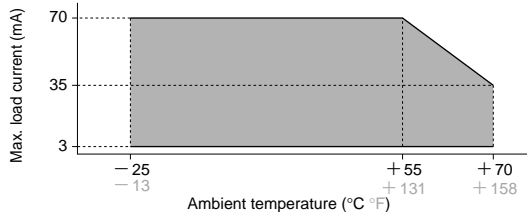

Wiring diagram

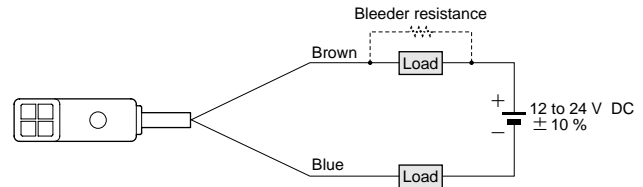

Conditions for the load

- 1) The load should not be actuated by the leakage current (0.8 mA) in the OFF state.
- 2) The load should be actuated by (supply voltage - 3 V) in the ON state.
- 3) The current in the ON state should be between 3 to 70 mA DC.
 (In case the current is less than 3 mA, connect a bleeder resistance in parallel to the load so that a current of 3 mA, or more, flows.)

GL-8/8U

SENSING CHARACTERISTICS (TYPICAL)

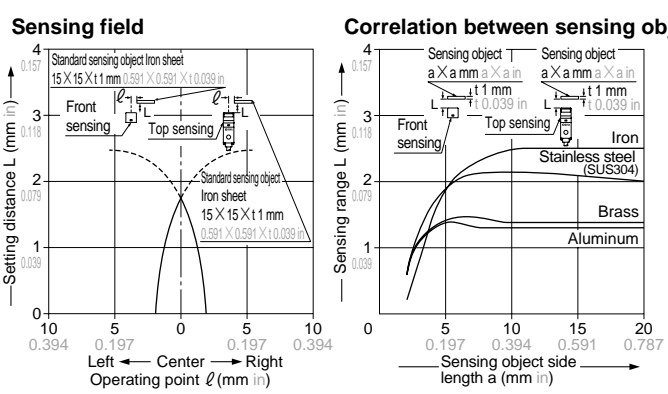

As the sensing object size becomes smaller than the standard size (iron sheet 15 × 15 × t 1 mm 0.591 × 0.591 × t 0.039 in), the sensing range shortens as shown in the left figure.

PRECAUTIONS FOR PROPER USE

Refer to p.1152~ for general precautions.

Warning: This product is not a safety sensor. Its use is not intended or designed to protect life and prevent body injury or property damage from dangerous parts of machinery. It is a normal object detection sensor.

Mounting

- Make sure to mount with an M3 (length 12 mm 0.472 in or more) truss head screw with a tightening torque of 0.5 N·m or less.

(Do not use a flat head screw or a pan head screw.)

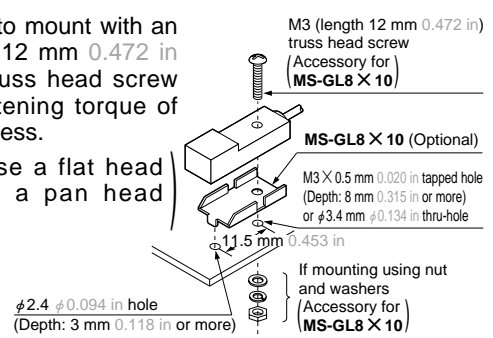

Influence of surrounding metal

- When there is a metal near the sensor, keep the minimum separation distance specified below.

GL-8F X 10, GL-8FU X 10

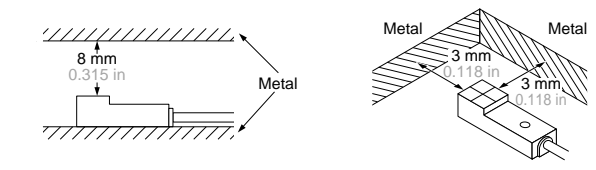

GL-8H X 10, GL-8HU X 10

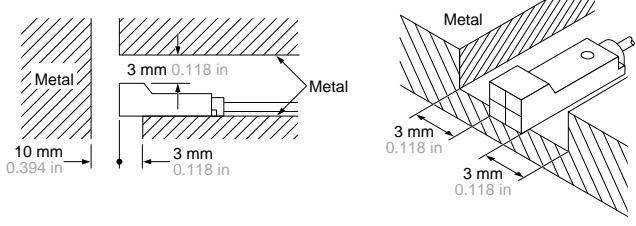

Mutual interference prevention

- When two or more sensors are installed in parallel or face to face, keep the minimum separation distance specified below to avoid mutual interference.

		A	B
GL-8F X 10, GL-8FU X 10	Between 'I' type and non 'I' type	0 mm (Note 2)	15 mm 0.591 in
	Between two 'I' types or two non 'I' types	20 mm 0.787 in	40 mm 1.575 in
GL-8H X 10, GL-8HU X 10	Between 'I' type and non 'I' type	0 mm (Note 2)	15 mm 0.591 in
	Between two 'I' types or two non 'I' types	25 mm 0.984 in	40 mm 1.575 in

Notes: 1) 'I' in the model No. specifies the different frequency type.
 2) Close mounting is possible for up to two sensors. When mounting three sensors or more, at an equal spacing, in a row, the minimum value of dimension 'A' should be as given below.
 GL-8F X 10, GL-8FU X 10: 6 mm 0.236 in
 GL-8H X 10, GL-8HU X 10: 8.5 mm 0.335 in

Sensing range

- The sensing range is specified for the standard sensing object (iron sheet 15 × 15 × t 1 mm 0.591 × 0.591 × t 0.039 in).

With a non-ferrous metal, the sensing range is obtained by multiplying with the correction coefficient specified on the right.

Further, the sensing range also changes if the sensing object is smaller than the standard sensing object (iron sheet 15 × 15 × t 1 mm 0.591 × 0.591 × t 0.039 in) or if the sensing object is plated.

Correction coefficient

Metal	Model No.	All models
Iron sheet		1
Stainless Steel (SUS304)		0.80 approx.
Brass		0.54 approx.
Aluminum		0.52 approx.

PRECAUTIONS FOR PROPER USE

Refer to [p.1152](#)~ for general precautions.

Wiring

- Make sure that the power supply is off while wiring.
- Verify that the supply voltage variation is within the rating.
- If power is supplied from a commercial switching regulator, ensure that the frame ground (F.G.) terminal of the power supply is connected to an actual ground.
- In case noise generating equipment (switching regulator, inverter motor, etc.) is used in the vicinity of this sensor, connect the frame ground (F.G.) terminal of the equipment to an actual ground.
- Do not run the wires together with high-voltage lines or power lines or put them in the same raceway. This can cause malfunction due to induction.

Others

- Do not use during the initial transient time [200 ms (DC 2-wire type: 50 ms)] after the power supply is switched on.
- Take care that the sensor does not come in direct contact with oil, grease, or organic solvents, such as, thinner, etc.
- Make sure that the sensing end is not covered with metal dust, scrap or spatter. It will result in malfunction.

DIMENSIONS (Unit: mm in) The CAD data in the dimensions can be downloaded from the SUNX website: <http://www.sunx.co.jp/>

GL-8F□ × 10
GL-8FU□ × 10 Sensor

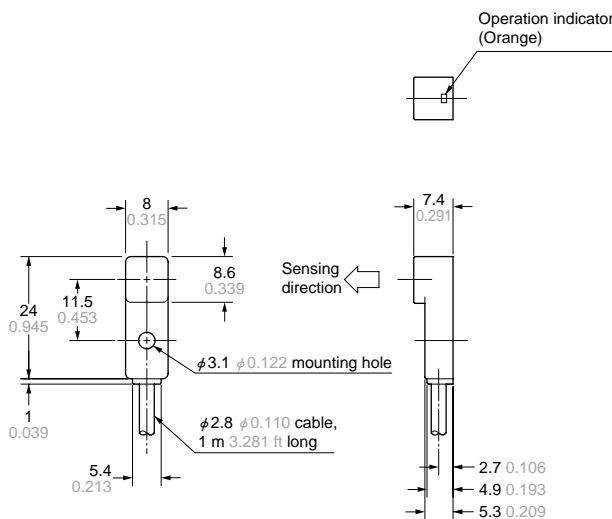

GL-8H□ × 10
GL-8HU□ × 10 Sensor

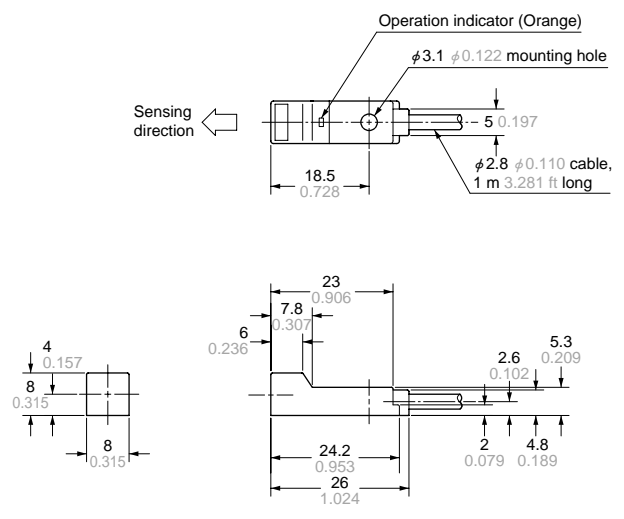

MS-GL8 × 10 Sensor mounting bracket (Optional)

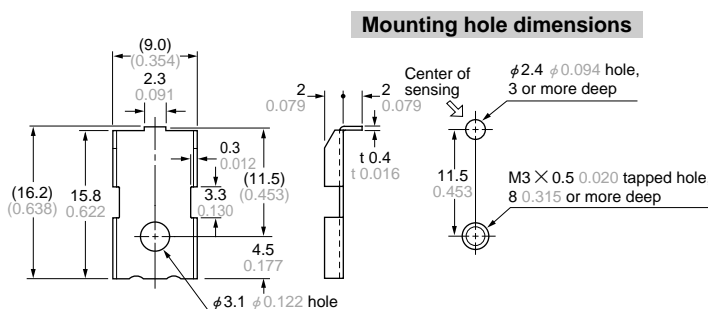

Material: Stainless steel (SUS304)
1 pc. each of M3 (length 12 mm 0.472 in) truss head screw, nut, spring washer and plain washer is attached.

GXL

GL-6

GL-8/8U

GL-N12

GL-18H/18HL

GL-U/FU

GX-N

GX

Amplifier-separated
GA-10/GH

Amplifier Built-in