

GL-N12 SERIES

Low Price Rectangular-shaped Inductive Proximity Sensor **Amplifier Built-in**

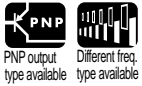

Wide variety with total cost reduction!



Exclusive mounting bracket is needless

The **GL-N12** series can be reliably fixed even without an exclusive mounting bracket as a boss is provided on the bottom face of the sensor to prevent rotation.

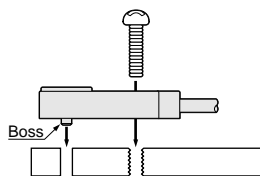

Low price

The **GL-N12** series is recommended to large volume users for cost reduction.

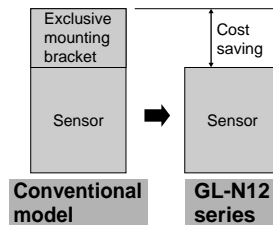

Cost saving is achieved as the exclusive mounting bracket is not required.

The **GL-N12** series is available in units of ten sensors.

Wide variation

A wide variety of 16 types, front sensing type / top sensing type, normally open type / normally closed type, as well as, different frequency type, PNP output type, etc., is available.

You can choose from the vastly increased variety to suit your application.

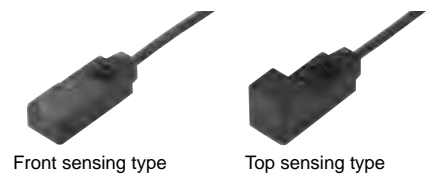

Long sensing range

It achieves a sensing range of 4 mm 0.157 in with a 12 mm 0.472 in square-size sensing part.

It can reliably detect an object even if its position varies slightly.

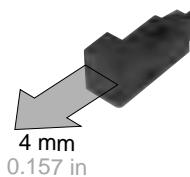

Waterproof

Since the sensor has IP67 protection, it can withstand water splashes.

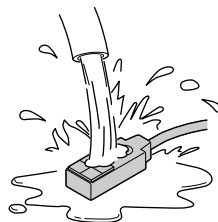

APPLICATIONS

Confirming shutting / opening of door

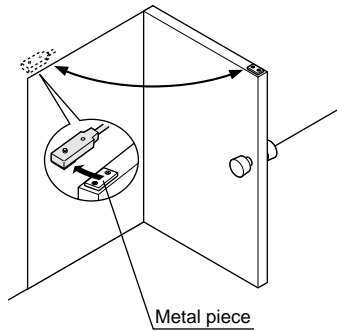

Detecting rolling coins

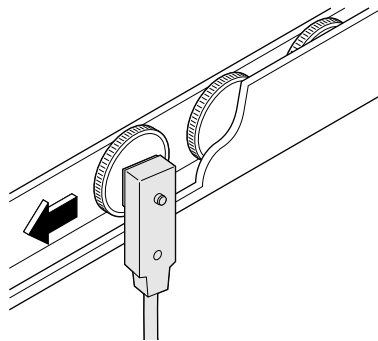

Detecting metal parts on a feeder

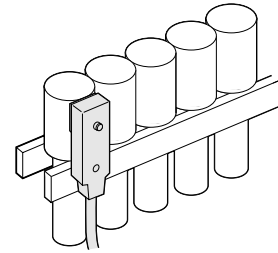

ORDER GUIDE

Type	Appearance (mm in)	Sensing range (Note 1)	Model No. (Note 2)	Output	Output operation
Boss type			GL-N12F X 10	NPN open-collector transistor	Normally open
			GL-N12FI X 10		Normally closed
			GL-N12FB X 10	PNP open-collector transistor	Normally open
			GL-N12FIB X 10		Normally closed
			GL-N12F-P X 10	PNP open-collector transistor	Normally open
			GL-N12FI-P X 10		Normally closed
Top sensing			GL-N12H X 10	NPN open-collector transistor	Normally open
			GL-N12HI X 10		Normally closed
			GL-N12HB X 10	PNP open-collector transistor	Normally open
			GL-N12HIB X 10		Normally closed
			GL-N12H-P X 10	PNP open-collector transistor	Normally open
			GL-N12HI-P X 10		Normally closed
			GL-N12HB-P X 10	PNP open-collector transistor	Normally open
			GL-N12HIB-P X 10		Normally closed

Notes: 1) The maximum operation distance stands for the maximum distance for which the sensor can detect the standard sensing object.
 The stable sensing range stands for the sensing range for which the sensor can stably detect the standard sensing object even if there is an ambient temperature drift and/or supply voltage fluctuation.
 2) 'I' in the model No. indicates a different frequency type.

NOTE: Low price rectangular-shaped inductive proximity sensors (GL-N12 series) are available in units of ten.

GL-N12

ORDER GUIDE

Without boss type (Front sensing type, NPN output type and normally open type only) Units of ten

The without boss type is also available. (Standard: with boss type)

Model No.: **GL-12F X 10** (Front sensing type) (cable length: 1 m 3.281 ft)

GL-12F-C5 X 10 (Front sensing type) (cable length: 5 m 16.404 ft)

MS-GL12 X 10 (Sensor mounting bracket)

• **MS-GL12 X 10**

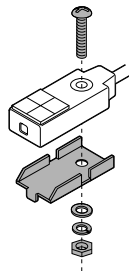

1 pc. each of M3 (length 12 mm 0.472 in) pan head screw, plain washer, spring washer and rubber washer ($\phi 9.5 \times t 0.5$ mm $\phi 0.374 \times t 0.020$ in) is attached.

5 m 16.404 ft cable length type

5 m 16.404 ft cable length type (standard: 1 m 3.281 ft) is also available.

• **Table of Model Nos.**

Type		Standard	5 m 16.404 ft cable length type	
Boss type	Front sensing	NPN output	GL-N12F X 10	GL-N12F-C5 X 10
			GL-N12FI X 10	GL-N12FI-C5 X 10
			GL-N12FB X 10	GL-N12FB-C5 X 10
			GL-N12FIB X 10	_____
	PNP output		GL-N12F-P X 10	_____
			GL-N12FI-P X 10	_____
			GL-N12FB-P X 10	_____
			GL-N12FIB-P X 10	_____
	Top sensing	NPN output	GL-N12H X 10	GL-N12H-C5 X 10
			GL-N12HI X 10	GL-N12HI-C5 X 10
			GL-N12HB X 10	GL-N12HB-C5 X 10
			GL-N12HIB X 10	_____
PNP output		GL-N12H-P X 10	GL-N12H-P-C5 X 10	
		GL-N12HI-P X 10	_____	
		GL-N12HB-P X 10	GL-N12HB-P-C5 X 10	
		GL-N12HIB-P X 10	_____	

SPECIFICATIONS

Item	Model No.	Type	Boss type							
			NPN output				PNP output			
			Front sensing		Top sensing		Front sensing		Top sensing	
			Different frequency		Different frequency		Different frequency		Different frequency	
	Normally open	GL-N12FX10 (Note 1)	GL-N12FI X10	GL-N12HX10	GL-N12HI X10	GL-N12F-P X10	GL-N12FI-P X10	GL-N12H-PX10	GL-N12HI-P X10	
	Normally closed	GL-N12FBX10	GL-N12FIB X10	GL-N12HB X10	GL-N12HIB X10	GL-N12FB-PX10	GL-N12FIB-PX10	GL-N12HB-PX10	GL-N12HIB-PX10	
Max. operation distance (Note 2)		4 ± 0.5 mm 0.157 ± 0.020 in								
Stable sensing range (Note 2)		0 to 3 mm 0 to 0.118 in								
Standard sensing object		Iron sheet 20 × 20 × t 1 mm 0.787 × 0.787 × t 0.039 in								
Hysteresis		20 % or less of operation distance								
Supply voltage		12 to 24 V DC ± 10 % Ripple P-P 10 % or less								
Current consumption		10 mA or less				15 mA or less				
Output		NPN open-collector transistor • Maximum sink current: 100 mA • Applied voltage: 30 V DC or less (between output and 0 V) • Residual voltage: 1 V or less (at 100 mA sink current) 0.4 V or less (at 16 mA sink current)				PNP open-collector transistor • Maximum source current: 100 mA • Applied voltage: 30 V DC or less (between output and +V) • Residual voltage: 1 V or less (at 100 mA source current) 0.4 V or less (at 16 mA source current)				
Utilization category		DC-12 or DC-13								
Max. response frequency		1.3 kHz								
Operation indicator		Orange LED (lights up when the output is ON)								
Environmental resistance	Pollution degree		3 (Industrial environment)							
	Protection		IP67 (IEC)							
	Ambient temperature		- 10 to + 55 °C + 14 to + 131 °F, Storage: - 25 to + 70 °C - 13 to + 158 °F							
	Ambient humidity		45 to 85 % RH, Storage: 35 to 95 % RH							
	EMC		EN 50081-2, EN 50082-2, EN 60947-5-2							
	Voltage withstandability		1,000 V AC for one min. between all supply terminals connected together and enclosure							
	Insulation resistance		50 MΩ, or more, with 250 V DC megger between all supply terminals connected together and enclosure							
	Shock resistance		1,000 m/s ² (100 G approx.) acceleration in X, Y and Z directions for three times each							
Sensing range variation	Temperature characteristics		Over ambient temperature range - 10 to + 55 °C + 14 to + 131 °F: Within ± 15 % of sensing range at 20 °C + 68 °F							
	Voltage characteristics		Within ± 2 % for ± 10 % fluctuation of the supply voltage							
Material		Enclosure: Polyallylate								
Cable		0.18 mm ² 3-core cabtyre cable, 1 m 3.281 ft long								
Cable extension		Extension up to total 100 m 328.084 ft is possible with 0.3 mm ² , or more, cable.								
Weight		20 g approx.								

- Notes: 1) The without boss type is also available.
 The specifications are the same as for the with boss type. (However, max. response frequency: 500 Hz, operation indicator: Red LED)
 2) The maximum operation distance stands for the maximum distance for which the sensor can detect the standard sensing object.
 The stable sensing range stands for the sensing range for which the sensor can stably detect the standard sensing object even if there is an ambient temperature drift and/or supply voltage fluctuation.

GXL

GL-6

GL-8/8U

Amplifier Built-in
GL-N12

GL-18H/18HL

GX-U/FU

GX-N

GX

Amplifier-separated
GA-10/GH

GL-N12

I/O CIRCUIT AND WIRING DIAGRAMS

NPN output type

I/O circuit diagram

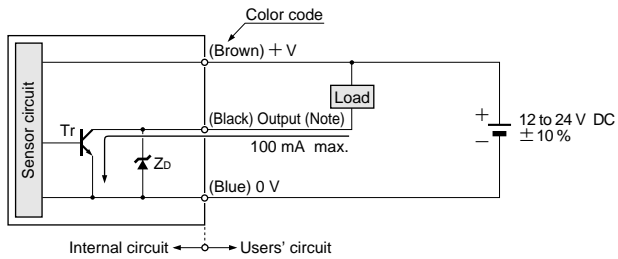

Symbols ... Zd: Surge absorption zener diode
Tr: NPN output transistor

Note: Please carry out the wiring carefully since protection circuit against reverse power supply connection is not incorporated. Further, the output is not incorporated with a short-circuit protection circuit. Do not connect it directly to a power supply or a capacitive load.

Wiring diagram

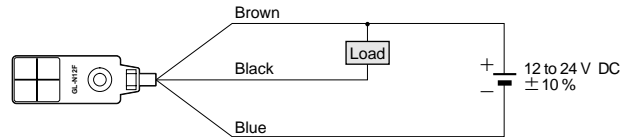

PNP output type

I/O circuit diagram

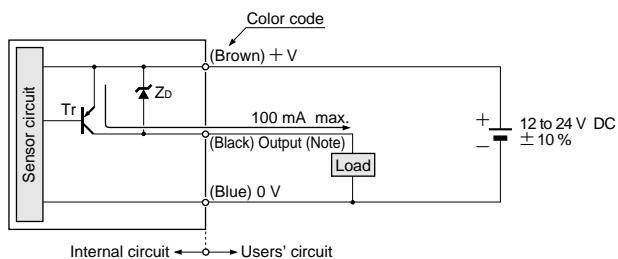

Symbols ... Zd: Surge absorption zener diode
Tr: PNP output transistor

Note: Please carry out the wiring carefully since protection circuit against reverse power supply connection is not incorporated. Further, the output is not incorporated with a short-circuit protection circuit. Do not connect it directly to a power supply or a capacitive load.

Wiring diagram

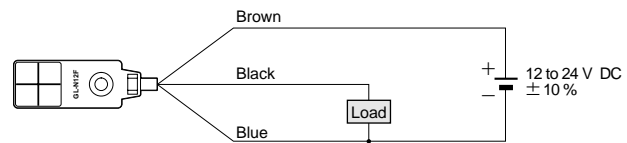

SENSING CHARACTERISTICS (TYPICAL)

Sensing field

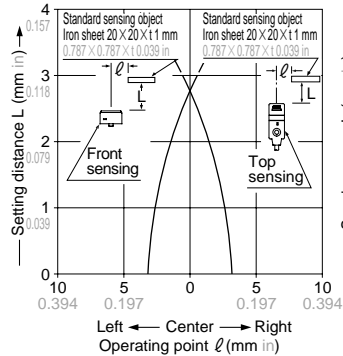

Correlation between sensing object size and sensing range

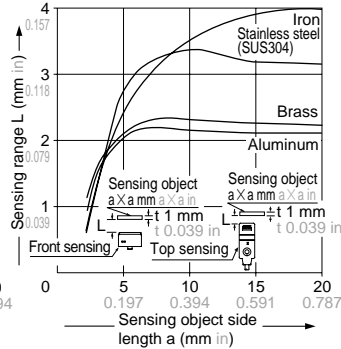

As the sensing object size becomes smaller than the standard size (iron sheet 20 × 20 × t 1 mm 0.787 × 0.787 × t 0.039 in), the sensing range shortens as shown in the left figure.

PRECAUTIONS FOR PROPER USE

Refer to p.1152~ for general precautions.



This product is not a safety sensor. Its use is not intended or designed to protect life and prevent body injury or property damage from dangerous parts of machinery. It is a normal object detection sensor.

Mounting

- The tightening torque should be 0.5 N·m or less.
- To mount the sensor with a nut, the mounting hole diameter should be $\phi 3.4$ mm $\phi 0.134$ in. Further, the hole in which the boss is inserted should be $\phi 2.5$ mm $\phi 0.098$ in and 3 mm 0.118 in, or more, deep.

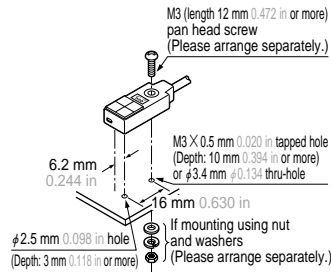

Influence of surrounding metal

- When there is a metal near the sensor, keep the minimum separation distance specified below.

GL-N12F \square X 10

(Unit: mm in)

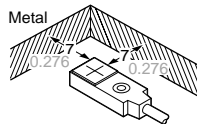
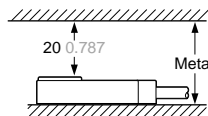

GL-N12H \square X 10

(Unit: mm in)

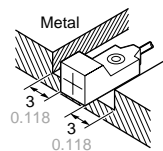
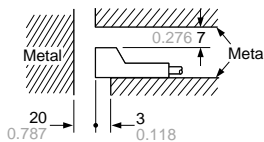

Mutual interference prevention

- When two or more sensors are installed in parallel or face to face, keep the minimum separation distance specified below to avoid mutual interference.

	GL-N12F \square X 10, GL-N12H \square X 10	GL-N12F \square X 10	GL-N12H \square X 10
	Between 'I' type and non 'I' type	Between two 'I' types or two non 'I' types	
A	0 mm 0 in (Note 2)	25 mm 0.984 in	
B	25 mm 0.984 in	50 mm 1.969 in	

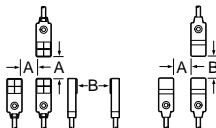

Notes: 1) 'I' in the model No. specifies the different frequency type.

2) Close mounting is possible for up to two sensors.

When mounting three sensors or more, at an equal spacing, in a row, the minimum value of dimension 'A' should be 6.5 mm 0.256 in.

Sensing range

- The sensing range is specified for the standard sensing object (iron sheet $20 \times 20 \times t 1$ mm $0.787 \times 0.787 \times t 0.039$ in).

With a non-ferrous metal, the sensing range is obtained by multiplying with the correction coefficient specified on the right. Further, the sensing range also change if the sensing object is smaller than the standard sensing object (iron sheet $20 \times 20 \times t 1$ mm $0.787 \times 0.787 \times t 0.039$ in) or if the sensing object is plated.

Correction coefficient

Model No.	GL-N12F \square X 10 GL-N12H \square X 10
Metal	
Iron	1
Stainless steel (SUS304)	0.79 approx. (Note 1)
Brass	0.56 approx. (Note 2)
Aluminum	0.53 approx.

Notes: 1) GL-12F X 10 (Without boss type): 0.78 approx.
2) GL-12F X 10 (Without boss type): 0.55 approx.

Wiring

- Please carry out the wiring carefully since protection circuit against reverse power supply connection is not incorporated. Further, the output is not incorporated with a short-circuit protection circuit. Do not connect it directly to a power supply or a capacitive load.

Others

- Do not use during the initial transient time [50 ms (GL-12F X 10: 10 ms)] after the power supply is switched on.

GXL

GL-6

GL-8/8U

GL-N12

GL-18H/18HL

GX-U/FU

GX-N

GX

Amplifier-separated

GA-10/GH

GL-N12

DIMENSIONS (Unit: mm in) The CAD data in the dimensions can be downloaded from the SUNX website: <http://www.sunx.co.jp/>

GL-N12F □ X 10 Sensor

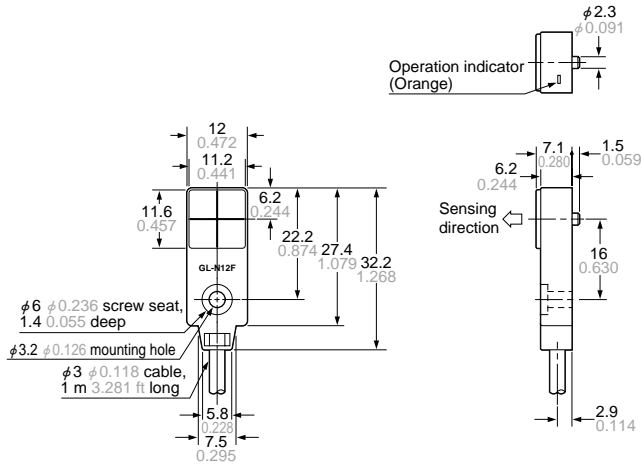

GL-N12H □ X 10 Sensor

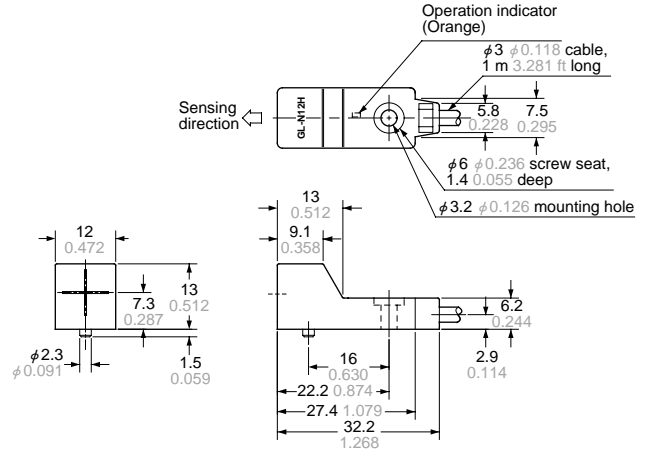

GL-12F X 10 Sensor

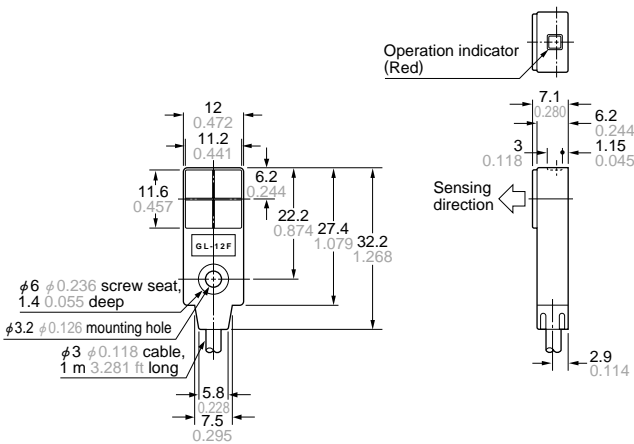

MS-GL12 X 10 Sensor mounting bracket (Optional)

Mounting hole dimensions

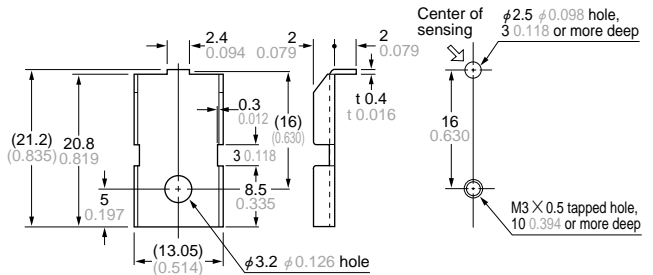

Material: Cold rolled carbon steel (SPCC)
(Nickel plated)

1 pc. each of M3 (length 12 mm 0.472 in) pan head screw, plain washer, spring washer and rubber washer ($\phi 9.5 \times t 0.5$ mm $\phi 0.374 \times t 0.020$ in) is attached.