

NA1-11

Small / Slim Object Detection Area Sensor



Cross-beam scanning system to detect slim objects

Refer to p.419~ for the light curtain.



Letter or visiting card detectable!

Slim objects can be detected by using the cross-beam scanning system.

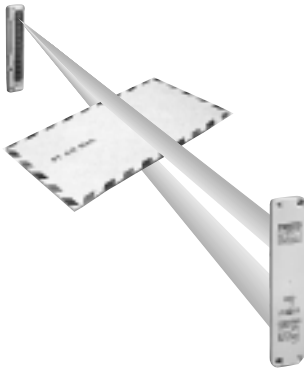

Emitting and receiving element pitch: 10 mm 0.394 in

A minimum sensing object size of $\phi 13.5$ mm $\phi 0.531$ in is realized by using an emitting and receiving element pitch of 10 mm 0.394 in.

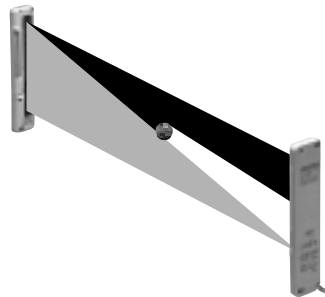

Just 10 mm 0.394 in thick

It is extremely slim, being just 10 mm 0.394 in thick. Further, it can be mounted in a narrow space since its cable exit direction is freely adjustable.



Flexible cable orientation

Wide area

Though being very slim, it realizes a wide sensing area of 1 m 3.281 ft length and 100 mm 3.937 in width. It is most suitable for object detection on a wide assembly line, or for detecting the dropping of, or incursion by, small objects whose travel path is uncertain.

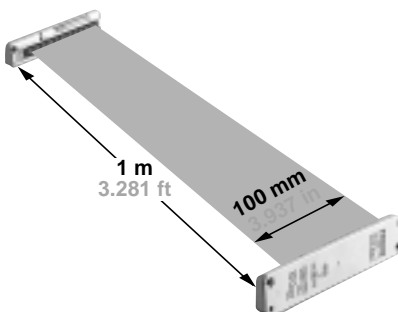

No synchronization wire

Wiring is saved and made simple as no synchronization wire is required between the emitter and the receiver.

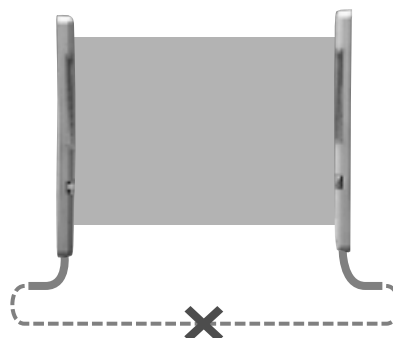

Globally useable

It conforms to the EMC Directive and has UL Recognition. Moreover, PNP output type, which is much in demand in Europe, is also available.



APPLICATIONS

Detecting post-cards

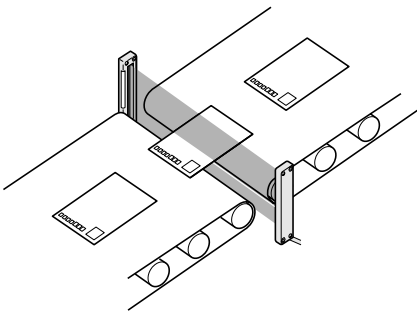

Detecting falling objects whose path is uncertain

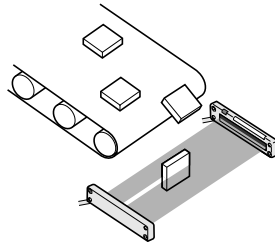

Detecting edge of moving object

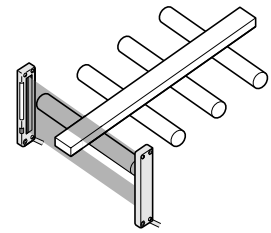

WARNING Never use this product in any personnel safety application.

Clearly visible indicator

A clearly visible large indicator, having a 55 mm 2.165 in width, is incorporated on both the emitter and the receiver. Further, if the sensing output is directly connected to the large indicator input, the indicator can be conveniently used as a large operation indicator. Moreover, its operation can be selected as lighting or blinking.

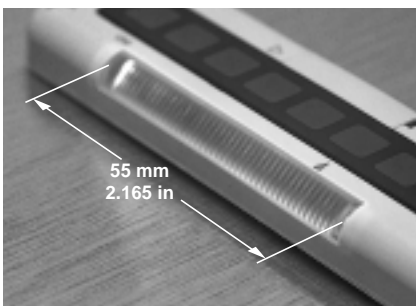

Cross-beam Scanning System

In a conventional area sensor, slim objects cannot be detected since the emitting and the receiving elements are scanned, synchronously, as a set. In contrast, in **NA1-11**, only the elements ① to ⑪ of the emitter are scanned to obtain emission. The elements of the receiver are not scanned, so that when element ① of the emitter emits light, all the elements of the receiver receive light. Hence, even if there is one element on the receiver which does not receive light, it results in light interrupted operation. With this technique, detection of slim objects is possible.

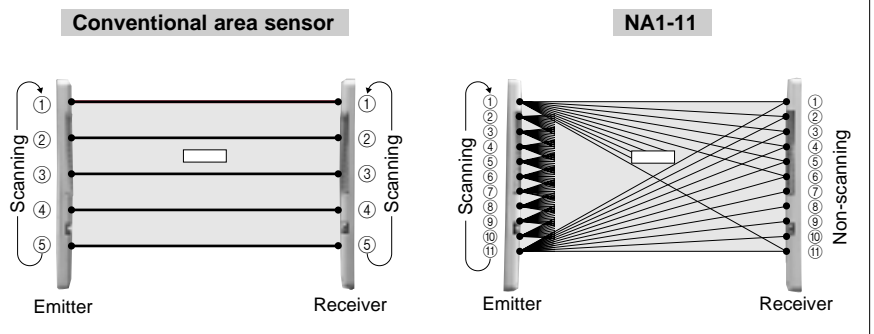

ORDER GUIDE

Type	Appearance	Sensing range (Note)	Model No.	Output
NPN output	<p>Sensing height: 100 mm 3.937 in</p> <p>5 m 16.404 ft cable length</p>	<p>0.17 to 1 m 0.558 to 3.281 ft</p>	NA1-11	NPN open-collector transistor
PNP output			NA1-11-C5	
	<p>No. of elements per emitter / receiver: 11</p> <p>Element pitch: 10 mm 0.394 in</p>		NA1-11-PN	PNP open-collector transistor

Note: The sensing range is the possible setting distance between the emitter and the receiver.
The sensor can detect an object less than 0.17 m 0.558 ft away.

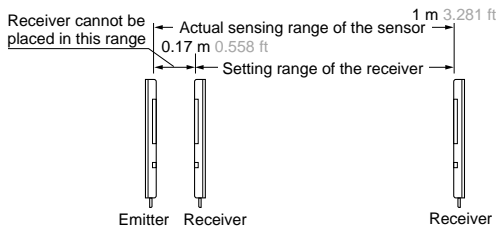

OPTIONS

Designation	Model No.	Description
Sensor mounting bracket	MS-NA1-1	Four bracket set Four M4 (length 15 mm 0.591 in) screws with washers, eight nuts, four hooks, four spacers and eight M4 (length 18 mm 0.709 in) screws with washers are attached. (Spacers are not attached with MS-NA1-1 .)
	MS-NA2-1	

Sensor mounting bracket

- **MS-NA1-1**

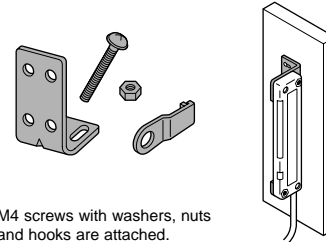

M4 screws with washers, nuts and hooks are attached.

- **MS-NA2-1**

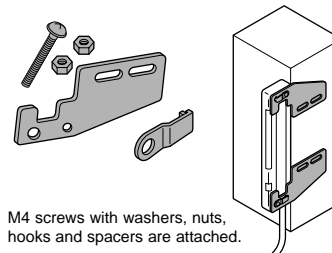

M4 screws with washers, nuts, hooks and spacers are attached.

SPECIFICATIONS

Type	NPN output	PNP output	
Item Model No.	NA1-11	NA1-11-PN	
Sensing height	100 mm 3.937 in		
Sensing range (Note 1)	0.17 to 1 m 0.558 to 3.281 ft		
Element pitch	10 mm 0.394 in		
Number of emitting / receiving elements	11 Nos. each on the emitter and the receiver, respectively		
Sensing object	φ 13.5 mm φ0.531 in or more opaque object (Note 2)		
Supply voltage	12 to 24 V DC ± 10 % Ripple P-P 10 % or less		
Current consumption	Emitter: 80 mA or less, Receiver: 100 mA or less		
Output	NPN open-collector transistor <ul style="list-style-type: none"> • Maximum sink current: 100 mA • Applied voltage: 30 V DC or less (between output and 0 V) • Residual voltage: 1 V or less (at 100 mA sink current) 0.4 V or less (at 16 mA sink current) 	PNP open-collector transistor <ul style="list-style-type: none"> • Maximum source current: 100 mA • Applied voltage: 30 V DC or less (between output and + V) • Residual voltage: 1 V or less (at 100 mA source current) 0.4 V or less (at 16 mA source current) 	
	Utilization category	DC-12 or DC-13	
	Output operation	ON or OFF when beam channel is interrupted, selectable by operation mode switch	
	Short-circuit protection	Incorporated	
Response time	In Dark state: 5 ms or less, In Light state: 10 ms or less		
Indicators	Emitter	Power indicator: Green LED (lights up when the power is ON) Large indicator: Orange LED (lights up or blinks when the large indicator input is Low, lighting pattern is selected by operation mode switch)	Power indicator: Green LED (lights up when the power is ON) Large indicator: Orange LED (lights up or blinks when the large indicator input is High, lighting pattern is selected by operation mode switch)
	Receiver	Operation indicator: Orange LED (lights up when the output is ON) Power indicator: Green LED (lights up when the power is ON) Large indicator: Orange LED (lights up or blinks when the large indicator input is Low, lighting pattern is selected by operation mode switch)	Operation indicator: Orange LED (lights up when the output is ON) Power indicator: Green LED (lights up when the power is ON) Large indicator: Orange LED (lights up or blinks when the large indicator input is High, lighting pattern is selected by operation mode switch)
Environmental resistance	Pollution degree	3 (Industrial environment)	
	Protection	IP62 (IEC)	
	Ambient temperature	- 10 to + 55 °C + 14 to + 131 °F (No dew condensation or icing allowed), Storage: - 20 to + 70 °C - 4 to + 158 °F	
	Ambient humidity	35 to 85 % RH, Storage: 35 to 85 % RH	
	Ambient illuminance	Sunlight: 10,000 lx at the light-receiving face, Incandescent light: 3,000 lx at the light-receiving face	
	EMC	EN 50081-2, EN 50082-2, EN 60947-5-2	
	Voltage withstandability	1,000 V AC for one min. between all supply terminals connected together and enclosure	
	Insulation resistance	20 MΩ, or more, with 250 V DC megger between all supply terminals connected together and enclosure	
	Shock resistance	10 to 150 Hz frequency, 1.5 mm 0.059 in amplitude in X, Y and Z directions for two hours each	
Emitting element	Infrared LED (cross-beam scanning system)		
Material	Enclosure: Heat-resistant ABS, Lens: Acrylic, Indicator cover: Acrylic		
Cable	0.3 mm ² 4-core (emitter: 3-core) oil resistant cabtyre cable, 2 m 6.562 ft long		
Cable extension	Extension up to total 100 m 328.084 ft is possible, for both emitter and receiver, with 0.3 mm ² , or more, cable.		
Weight	Emitter: 80 g approx., Receiver: 85 g approx.		

Notes: 1) The sensing range is the possible setting distance between the emitter and the receiver.
The sensor can detect an object less than 0.17 m 0.558 ft away.

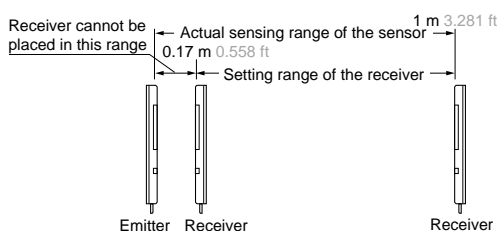

2) Although this product can detect slim objects by using the cross-beam scanning system, the size of the slim object which can be stably detected differs with the setting distance. When this sensor is used to detect slim objects, make sure to confirm stable detection using the actual objects.

NA1-11

I/O CIRCUIT AND WIRING DIAGRAMS

NA1-11 NPN output type

I/O circuit diagram

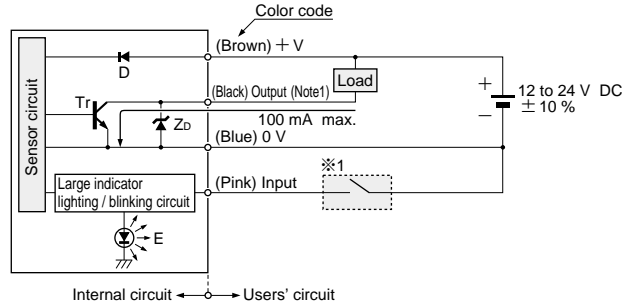

Notes: 1) The emitter does not incorporate the output (black).
 2) Unused wires must be insulated to ensure that they do not come into contact with wires already in use.

Symbols ... D : Reverse supply polarity protection diode
 Z_D: Surge absorption zener diode
 Tr: NPN output transistor
 E : Large indicator (INDICATOR)

Wiring diagram

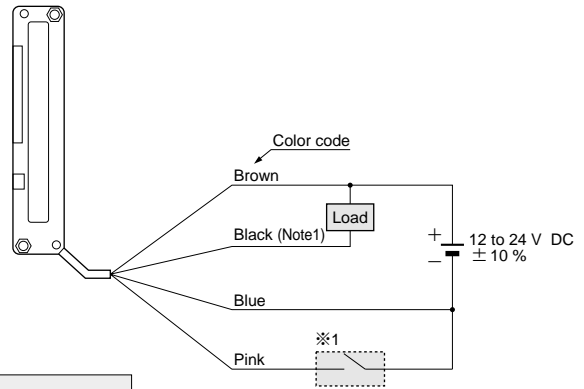

Notes: 1) The emitter does not incorporate the black lead wire.
 2) Unused wires must be insulated to ensure that they do not come into contact with wires already in use.

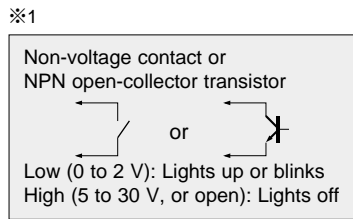

NA1-11-PN PNP output type

I/O circuit diagram

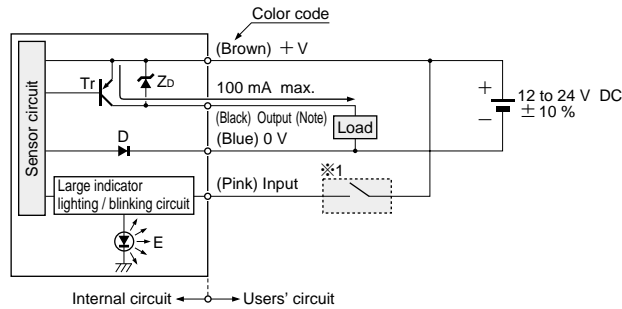

Notes: 1) The emitter does not incorporate the output (black).
 2) Unused wires must be insulated to ensure that they do not come into contact with wires already in use.

Symbols ... D : Reverse supply polarity protection diode
 Z_D: Surge absorption zener diode
 Tr: PNP output transistor
 E : Large indicator (INDICATOR)

Wiring diagram

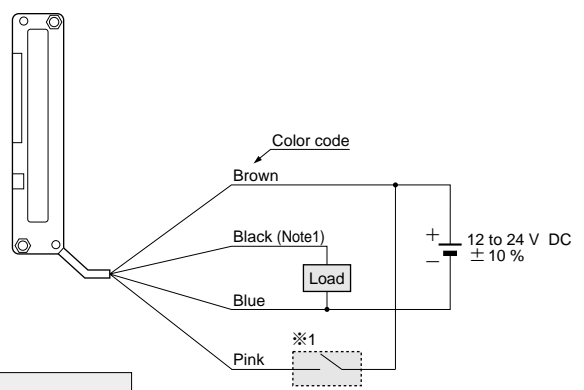

Notes: 1) The emitter does not incorporate the black lead wire.
 2) Unused wires must be insulated to ensure that they do not come into contact with wires already in use.

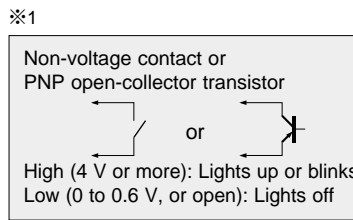

SENSING CHARACTERISTICS (TYPICAL)

Correlation between setting distance and excess gain

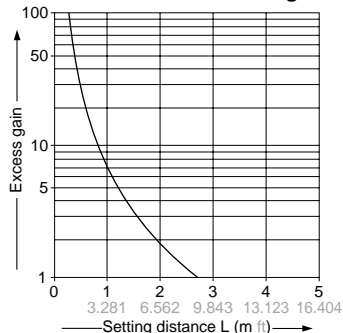

SENSING CHARACTERISTICS (TYPICAL)

Parallel deviation

Vertical direction

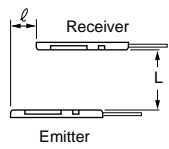

Horizontal direction

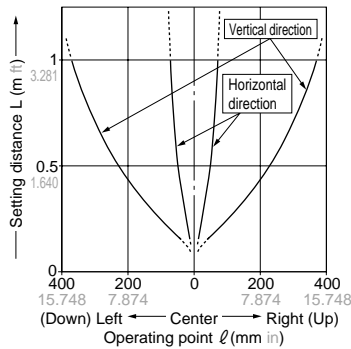
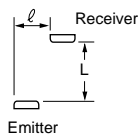

Angular deviation

Emitter angular deviation

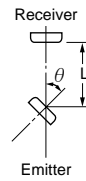

Receiver angular deviation

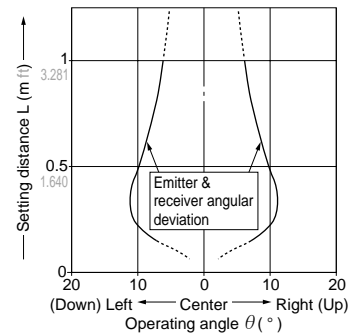
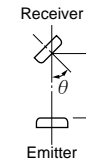

Correlation between setting distance and minimum length of detectable object

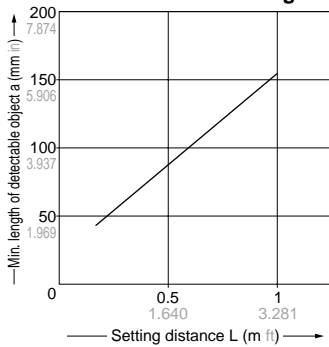

The minimum length of the detectable object, which lies in a plane perpendicular to the sensor front surface, varies with the setting distance, as shown in the left graph. However, note that the minimum length of the detectable object also varies with the object thickness.

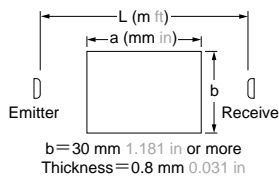

$b = 30 \text{ mm } 1.181 \text{ in or more}$
 Thickness = $0.8 \text{ mm } 0.031 \text{ in}$
 ※The sensing object is considered to be placed at the center of the sensing area.

PRECAUTIONS FOR PROPER USE

Refer to p.1135~ for general precautions.



- Never use this product as a sensing device for personnel protection
- For sensing devices to be used as safety devices for press machines or for personnel protection, use products which meet standards, such as OSHA, ANSI or IEC etc., for personnel protection applicable in each region or country.
- If this product is used as a sensing device for personnel protection, death or serious body injury could result.
- For a product which meets safety standards, use the following products.
 Type 4: **SF4-AH** series (p.420~) **SF2-EH** series (p.486~)
 Type 2: **SF2-A** series (p.446~) **SF2-N** series (p.464~)

Selection of large indicator operation

- Lighting / Blinking is selected by the operation mode switch on the emitter and the receiver.

Operation of large indicator	Operation mode switch	
	Emitter	Receiver
Lighting	LIGHT <input type="checkbox"/> BLINK <input type="checkbox"/>	LIGHT <input type="checkbox"/> BLINK <input type="checkbox"/>
Blinking	LIGHT <input type="checkbox"/> BLINK <input type="checkbox"/>	LIGHT <input type="checkbox"/> BLINK <input type="checkbox"/>

Mounting

- Use M4 screws with washers and M4 nuts. The tightening torque should be 0.5 N·m or less.
 (Please arrange the screws and nuts separately.)

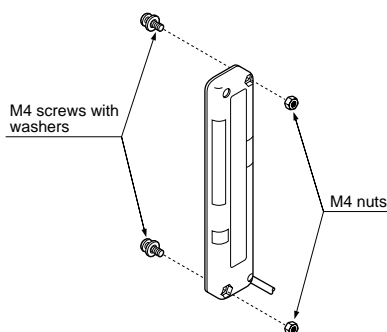

Selection of output operation

- The output operation mode is selected by the operation mode switch on the receiver.

(The switches must be set with the power supply off.
 The operation mode does not change if the switch setting is changed with the power supplied.)

Operation mode switch (Receiver)	Output operation	Operation indicator (Orange)
D-ON D/ON <input type="checkbox"/> L/ON <input type="checkbox"/>	ON in Dark state	Lights up when the output is ON
L-ON D/ON <input type="checkbox"/> L/ON <input type="checkbox"/>	OFF in Dark state	Lights up when the output is ON

Note: LIGHT / BLINK switch is not related to the output operation selection.

PRECAUTIONS FOR PROPER USE

Refer to p.1135~ for general precautions.

Wiring

- Make sure that the power supply is off while wiring and setting the mode switch.
- Verify that the supply voltage variation is within the rating.
- If power is supplied from a commercial switching regulator, ensure that the frame ground (F.G.) terminal of the power supply is connected to an actual ground.
- In case noise generating equipment (switching regulator, inverter motor, etc.) is used in the vicinity of this sensor, connect the frame ground (F.G.) terminal of the equipment to an actual ground.
- Do not run the wires together with high-voltage lines or power lines or put them in the same raceway. This can cause malfunction due to induction.

Others

- Do not use during the initial transient time (0.5 sec.) after the power supply is switched on.
- Avoid dust, dirt, and steam
- Take care that the sensor does not come in direct contact with water, oil, grease, or organic solvents, such as, thinner, etc.
- Take care that the sensor is not directly exposed to fluorescent light from a rapid-starter lamp or a high frequency lighting device, as it may affect the sensing performance.
- Although this sensor can detect slim objects by using the cross-beam scanning system, the size of the slim object which can be stably detected differs with the setting distance. Hence, when the sensor is used to detect slim objects, make sure to confirm stable detection using the actual objects.
- In case of this sensor, light from the emitter spreads above and below the sensor. Hence, take care that if there is a reflective object above or below the sensor it will affect the sensing.

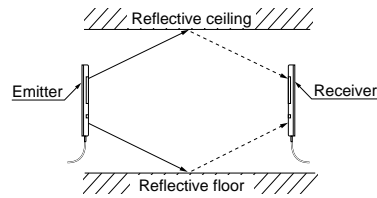

※ Refer to 'Parallel deviation' on p.533.

DIMENSIONS (Unit: mm in) The CAD data in the dimensions can be downloaded from the SUNX website: <http://www.sunx.co.jp/>

NA1-11 NA1-11-PN Sensor

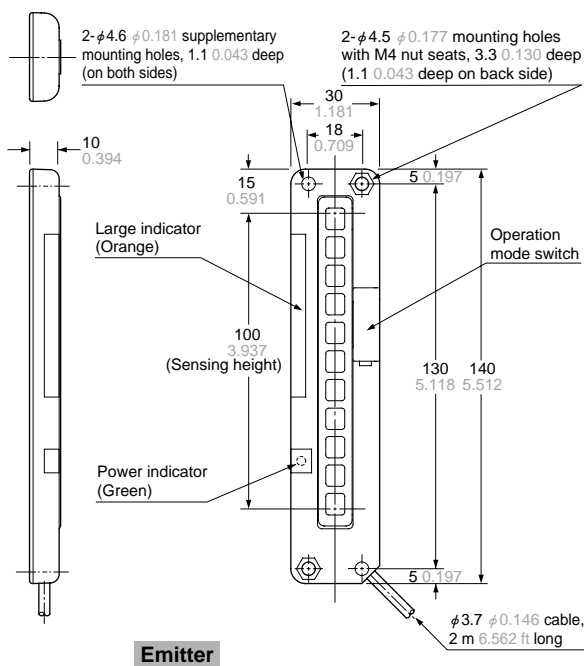

Emitter

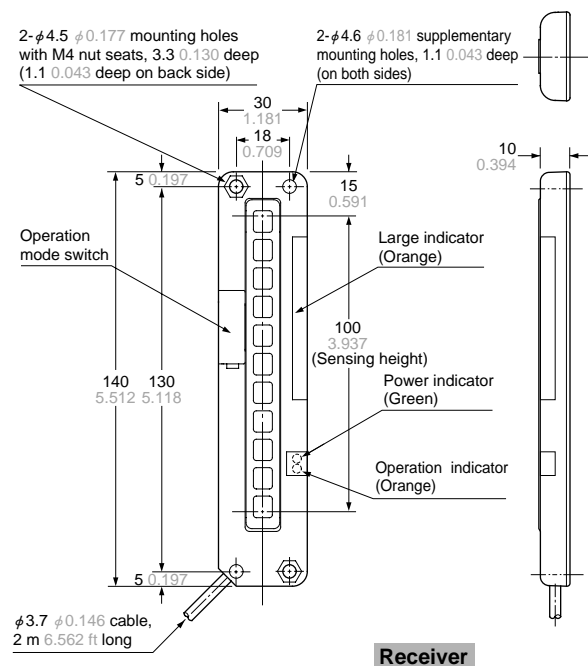

Receiver

