

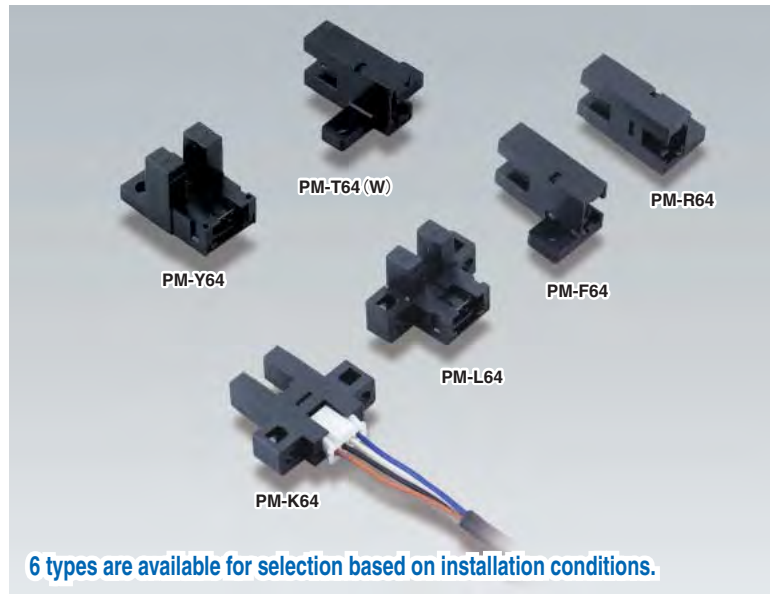

Built-in connector saves space!!



Contributes to space saving

The connector is built into the sensor. This greatly reduces the amount of space taken up compared to previous models.

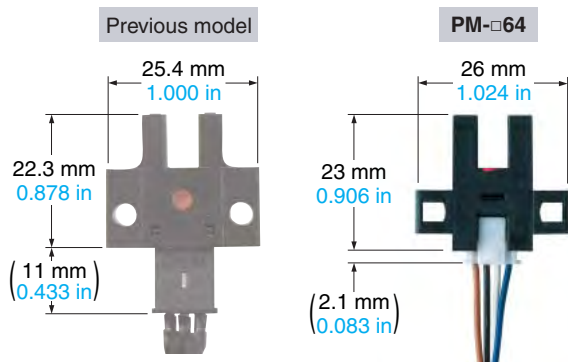

Can be connected using commercially-available connectors for higher reliability

The connector connection type eliminates the extra work of soldering and insulation processing. In addition, the connector used is a commercially-available multi-purpose connector which is also currently used by the DP-100 series of digital pressure sensors.



Digital pressure sensor DP-100 series

A P P L I C A T I O N S

Determining the pallet position

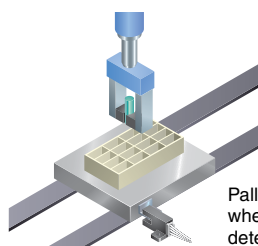

Sensing the starting point of a rotating body

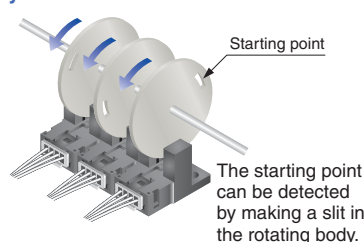

Sensing the starting point and overrun of a moving body

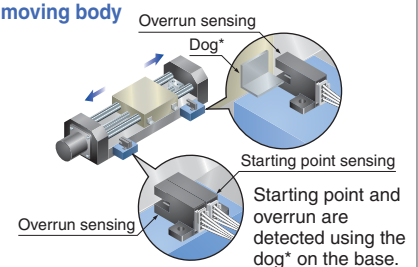

*The sensing object is most often a metal plate called a "dog".

Improved maintenance and workability reduce total cost significantly

The processing cost of connector cables can be drastically reduced through the use of commercially-available crimping connectors.

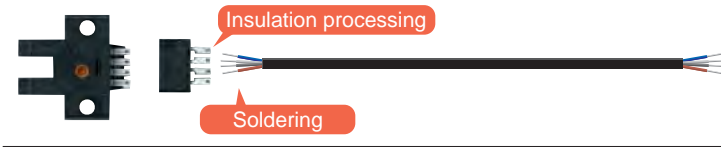
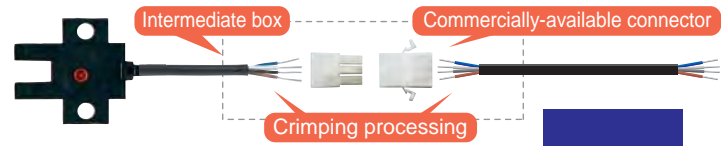
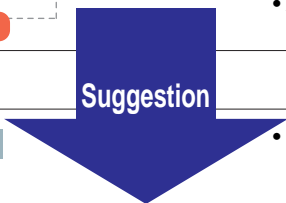
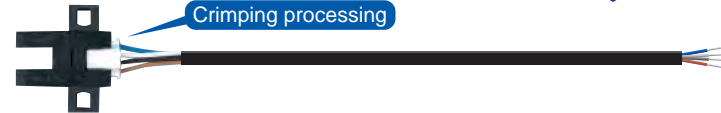
| | |
|---|---|
| <p>Previous model (Soldering: Connector type)</p>  | <ul style="list-style-type: none"> • Automation is hard because of soldering. • Insulation processing is required. • A large space is necessary at the terminal area. • Connectors are not reliable (not fully connected or seated). |
| <p>Previous model (Converted to the cable-type commercially-available connector)</p>  | <ul style="list-style-type: none"> • Crimping processing is required for two areas. • A set of commercially-available connectors is necessary. • There are many processes for cable connections. • A intermediate box is required. |
| <p>Suggestion</p>  | |
| <p>PM-64 series (Built-in commercially-available connector)</p>  | <ul style="list-style-type: none"> • Crimping processing makes automation possible so the connectors are also highly reliable. • Soldering, insulation processing, and a intermediate box are not necessary. • Connectors are widely available. • Mounting in small spaces is easy. • Strongly connected using a locking connector. • 1 m 3.281 ft, 2 m 6.562 ft, 3 m 9.843 ft, and 5 m 16.404 ft connector cables are available. |

OPTIONS

| Designation | Model No. | Description | |
|---|--------------------|------------------------------------|--|
| Connector attached cable | CN-14A-C1 | Length: 1 m 3.281 ft | 0.2 mm ² 4-core cabtyre cable with connector on one end Cable outer diameter: ø3.7 mm ø0.146 in |
| | CN-14A-C2 | Length: 2 m 6.562 ft | |
| | CN-14A-C3 | Length: 3 m 9.843 ft | |
| | CN-14A-C5 | Length: 5 m 16.404 ft | |
| Connector attached cable (Flexible cable) | CN-14A-R-C1 | Length: 1 m 3.281 ft | |
| | CN-14A-R-C2 | Length: 2 m 6.562 ft | |
| | CN-14A-R-C3 | Length: 3 m 9.843 ft | |
| | CN-14A-R-C5 | Length: 5 m 16.404 ft | |
| Connector | CN-14A | Set of 10 housings and 40 contacts | |

Connector attached cable

- CN-14A(-R)-C□

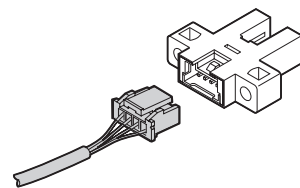

Connector

- CN-14A

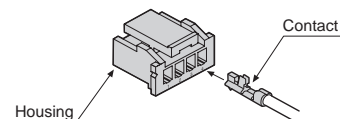

Recommended connector

Contact: SPHD-001T-P0.5, Housing: PAP-04V-S (Manufactured by J.S.T. Mfg. Co., Ltd.)

Note: Contact the manufacturer for details of the recommended products.

Recommended crimping tool

Model No. : YC-610R (Manufactured by J.S.T. Mfg. Co., Ltd.)

Note: Contact the manufacturer for details of the recommended products.

SPECIFICATIONS

| Item | Model No. (Note 2) | Type | Small and built-in connector type | | | | | |
|--------------------------|--------------------------|---|--|---------|-----------|---------|---------|---------|
| | | | K type | T type | L type | Y type | F type | R type |
| | | | NPN output | PM-K64 | PM-T64(W) | PM-L64 | PM-Y64 | PM-F64 |
| | | PNP output | PM-K64P | PM-T64P | PM-L64P | PM-Y64P | PM-F64P | PM-R64P |
| Sensing range | | | 5 mm 0.197 in (fixed) | | | | | |
| Minimum sensing object | | | 0.8 × 1.8 mm 0.031 × 0.071 in opaque object | | | | | |
| Hysteresis | | | 0.05 mm 0.002 in or less (Note 3) | | | | | |
| Repeatability | | | 0.01 mm 0.0004 in or less (Note 4) | | | | | |
| Supply voltage | | | 5 to 24 V DC ± 10 % Ripple P-P 10 % or less | | | | | |
| Current consumption | | | 15 mA or less | | | | | |
| Output | | <NPN output type> NPN open-collector transistor | <PNP output type> PNP open-collector transistor | | | | | |
| | Output operation | <ul style="list-style-type: none"> Maximum sink current: 50 mA Applied voltage: 30 V DC or less (between output and 0 V) Residual voltage: 0.7 V or less (at 50 mA sink current) 0.4 V or less (at 16 mA sink current) | <ul style="list-style-type: none"> Maximum source current: 50 mA Applied voltage: 30 V DC or less (between output and +V) Residual voltage: 0.7 V or less (at 50 mA source current) 0.4 V or less (at 16 mA source current) | | | | | |
| Response time | | | Incorporated with 2 outputs: Light-ON / Dark-ON | | | | | |
| Operation indicator | | | Under light received condition: 20 μs or less Under light interrupted condition: 100 μs or less (Response frequency: 1 kHz or more) | | | | | |
| Environmental resistance | Ambient temperature | | Orange LED (lights up under light received condition) | | | | | |
| | Ambient humidity | | -25 to +55 °C -13 to +131 °F (No dew condensation or icing allowed), Storage: -30 to +80 °C -22 to +176 °F | | | | | |
| | Ambient illuminance | | 35 to 85 % RH, Storage: 5 to 95 % RH | | | | | |
| | Voltage withstandability | | Fluorescent light: 1,000 lx at the light-receiving face | | | | | |
| | Insulation resistance | | 1,000 V AC for one min. between all supply terminals connected together and enclosure | | | | | |
| | Vibration resistance | | 50 MΩ, or more, with 250 V DC megger between all supply terminals connected together and enclosure | | | | | |
| | Shock resistance | | 10 to 2,000 Hz frequency, 1.5 mm 0.059 in amplitude in X, Y and Z directions for two hours each | | | | | |
| Emitting element | | | 15,000 m/s ² acceleration (1,500 G approx.) in X, Y and Z directions for three times each | | | | | |
| Material | | | Infrared LED (Peak emission wavelength: 940 nm 0.037 mil, non-modulated) | | | | | |
| Cable length | | | Enclosure: PBT, Slit cover: Polycarbonate | | | | | |
| Weight | | | Total length up to 100 m 328.084 ft is possible with 0.3 mm ² , or more, cable. (Note 5) | | | | | |
| | | | Net weight: 3 g approx. | | | | | |

- Notes: 1) Where measurement conditions have not been specified precisely, the conditions used were an ambient temperature of +23 °C +73.4 °F.
 2) **PM-T64W** is compatible for installation with the conventional model **PM-T53(B)**, allowing easy replacement from the conventional models.
 3) This is the value when a sensing object is moved in a lateral direction to the U-shape.
 4) This is the value when a sensing object is moved in a lateral direction to the U-shape and when the inserting length of the sensing board is 5 mm 0.197 in.
 5) Confirm that the sensor terminal voltage is more than 4.5 V when using an extension of over 20 m 65.617 ft.

DIMENSIONS (Unit: mm in)

The CAD data in the dimensions can be downloaded from the SUNX website: <http://www.sunx.com>

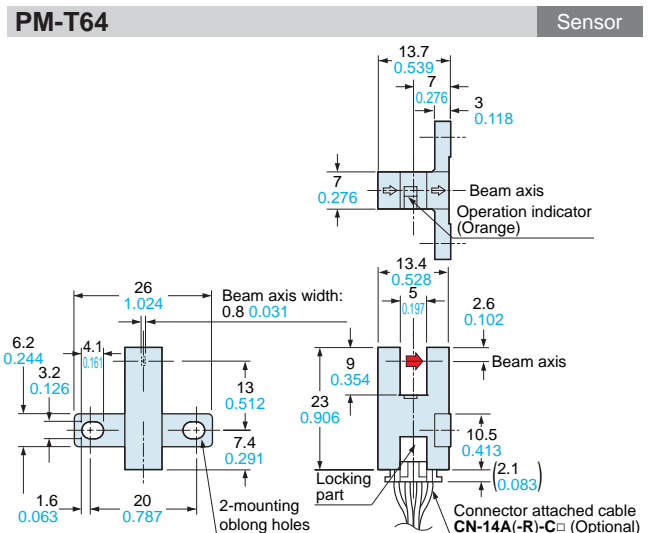
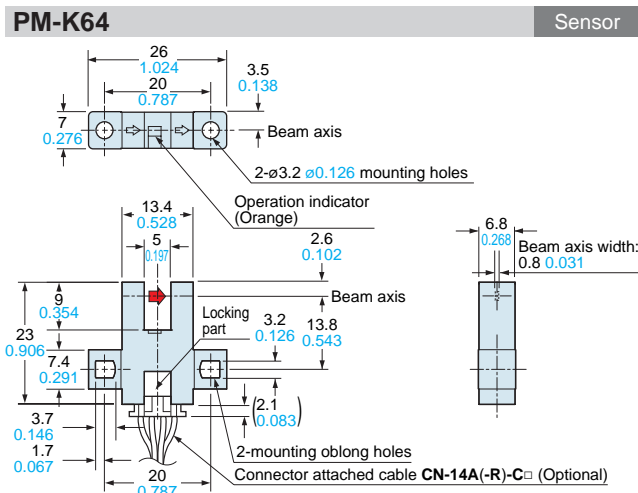

PM-T64W

Sensor

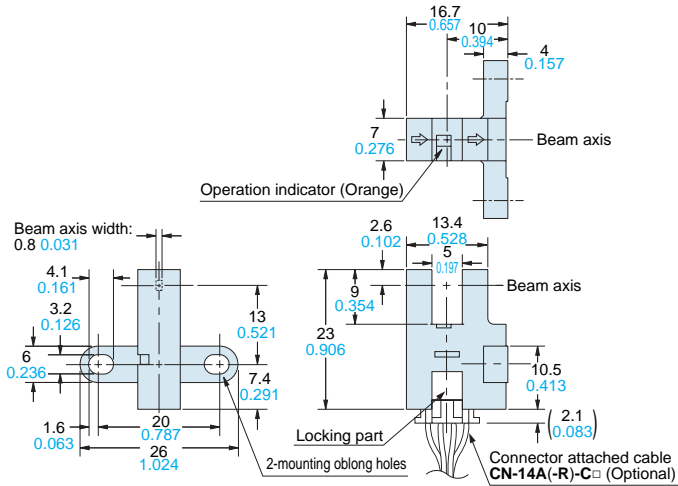

PM-L64

Sensor

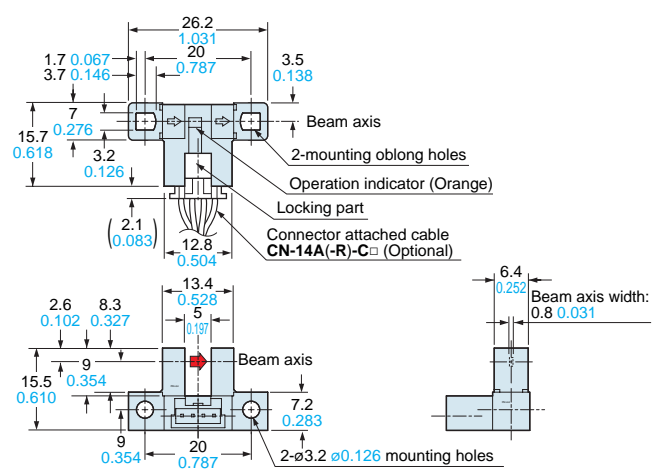

PM-Y64

Sensor

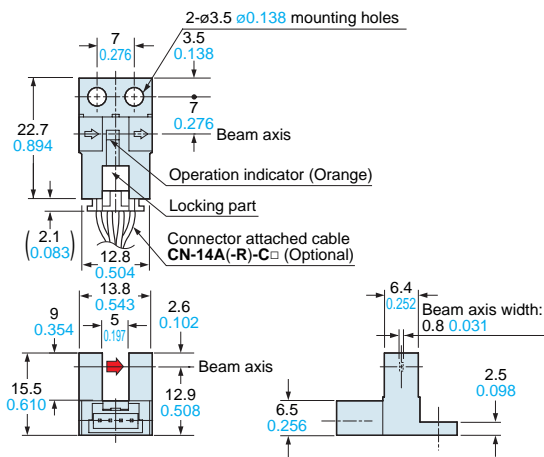

PM-F64

Sensor

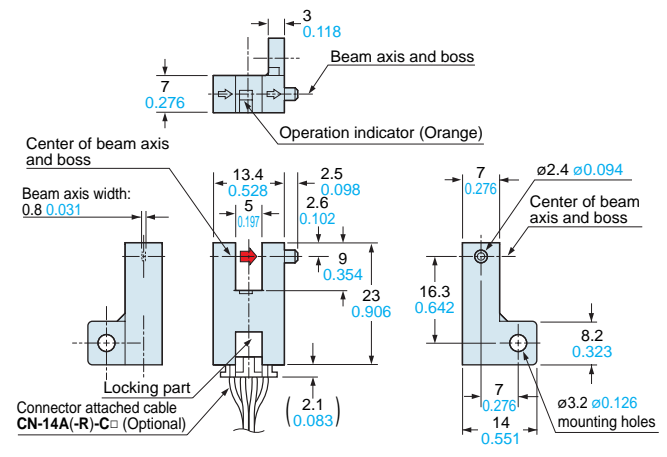

PM-R64

Sensor

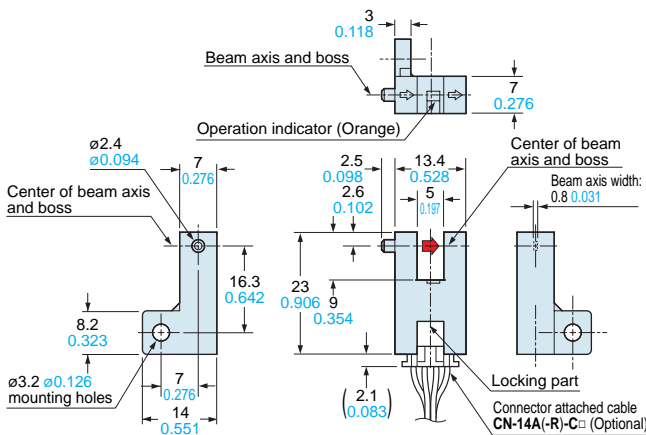

CN-14A-C □ CN-14A-R-C □ Connector attached cable (Optional)

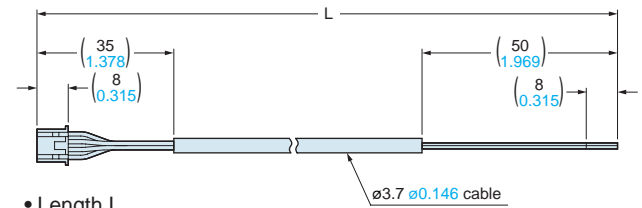

• Length L

| Model No. | Length L |
|---------------|---------------|
| CN-14A(-R)-C1 | 1,000 39.370 |
| CN-14A(-R)-C2 | 2,000 78.740 |
| CN-14A(-R)-C3 | 3,000 118.110 |
| CN-14A(-R)-C5 | 5,000 196.850 |

