

RX SERIES

Robust Photoelectric Sensor **Amplifier Built-in**

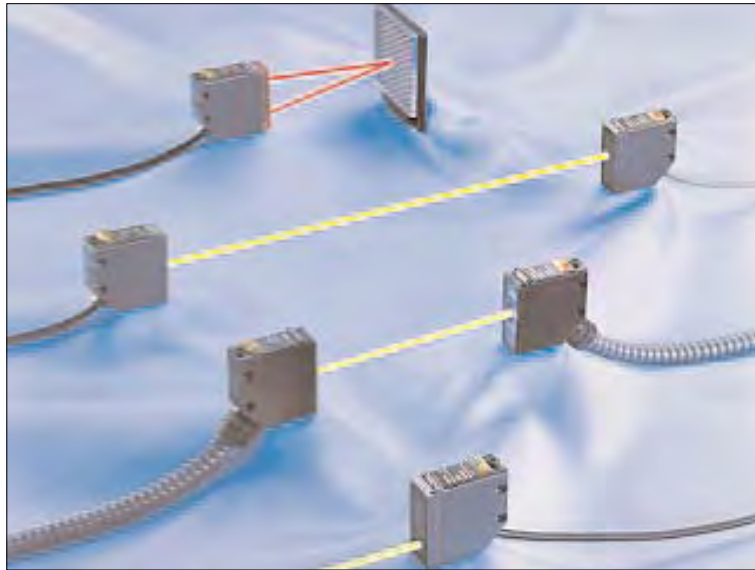

Advanced sensor technology



Waterproof

The sensor can be hosed down because of its IP67 construction. The equipment on which the sensor is mounted can be washed without any problem.

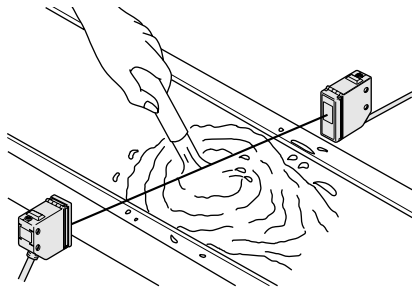

Note: However, take care that if it is exposed to water splashes during operation, it may detect a water drop itself.

Robust

The enclosure is robust as it is made of die-cast zinc alloy.

Test input (emission halt input)

Convenient for operation check before start-up. (Excluding the RX2 models)

The sensor operation is checked by interrupting the emission repeatedly and confirming that the output changes accordingly.

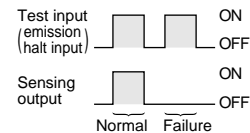

Automatic interference prevention function (Retroreflective and diffuse reflective type sensors only)

Two sensors can be mounted side by side because of the automatic interference prevention function. (Excluding the RX2 models)

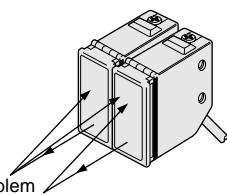

There is no problem even if the beam of the adjoining sensor is incident.

APPLICATIONS

Detecting person entering stacker crane path

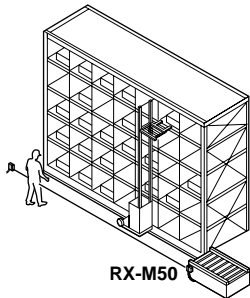

RX-M50

Sensing transparent sheet

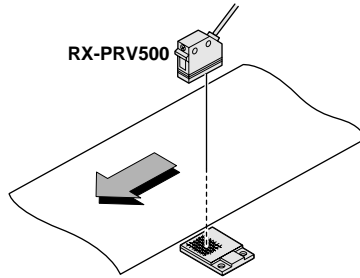

RX-PRV500

Confirming car position at parking garage

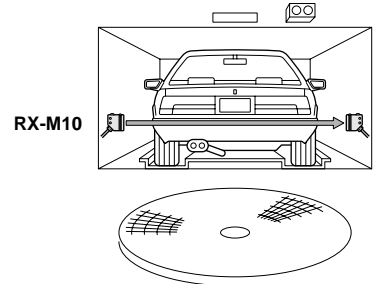

RX-M10

Detecting engines

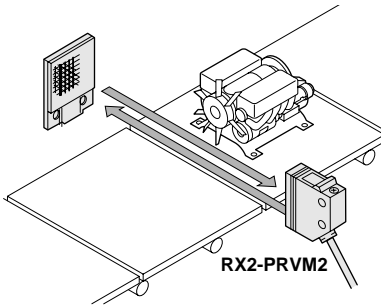

RX2-PRVM2

Counting cans

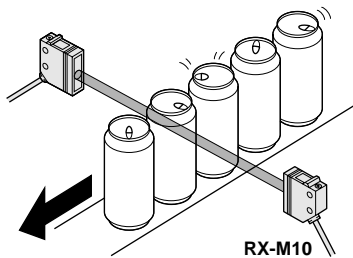

RX-M10

Sensing machine tools

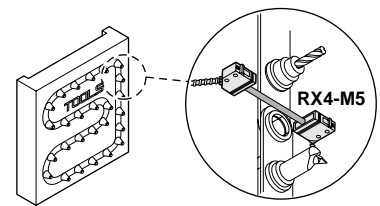

RX4-M5

RX... standard type

• Wide variety

Thru-beam type

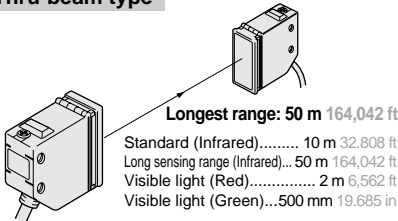

Diffuse reflective type

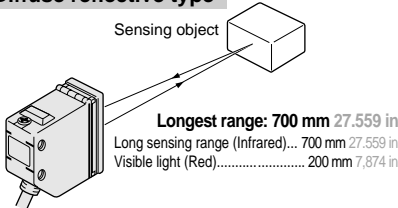

Retroreflective type

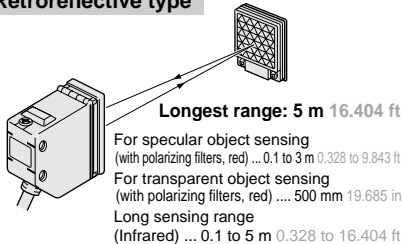

RX2... DC 2-wire type

• Wiring reduced by 1/3

Wiring can be completed by using only two, instead of three wires.

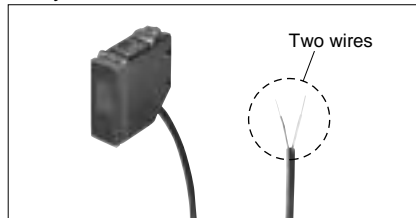

• Power supply cost: reduced to 1/30 or less
 Current consumption: 1 mA or less
 An additional power supply for the sensors is not required.

3-wire type

Wiring is time-consuming for the 3-wire sensors and an additional power supply is required.

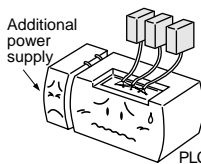

2-wire type

Wiring is simple with only two wires.

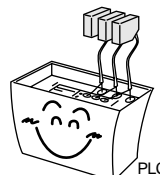

RX3... intelligent type (Orders accepted till December, 2003)

• Self-diagnosis function for internal circuit

In addition to the beam intensity check, the built-in microcomputer self-diagnoses the internal circuit and detects a circuit failure, should it occur.

The following parts ① to ⑥ are monitored constantly.

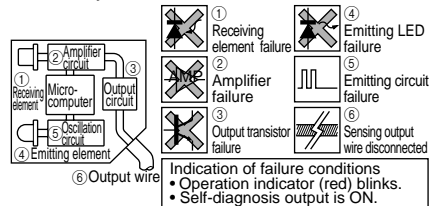

RX4... heavy duty type

• Durable against oil

IP67g (JEM) protection has been achieved by fluorine resin coating on the enclosure and by using oil resistant protective tube. This sensor can be used in a harsh environment.

IP67g (JEM)

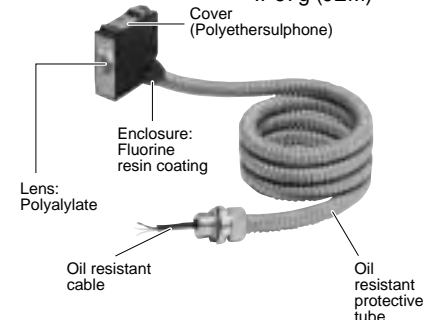

RX

ORDER GUIDE

Type		Appearance	Sensing range	Model No.	Output		
RX (Standard type)	Thru-beam		Infrared	10 m 32.808 ft	RX-M10	NPN open-collector transistor	
			For mark sensing	Long sensing range	50 m 164.062 ft		RX-M50
				Red	2 m 6.562 ft		RX-M2R
			Green	500 mm 19.685 in	RX-500G		
	Retroreflective		Red (with polarizing filters)	0.1 to 3 m (Note) 0.328 to 9.843 ft	RX-PRVM3		
			For transparent object sensing	500 mm (Note) 19.685 in	RX-PRV500		
			Infrared (long sensing range)	0.1 to 5 m (Note) 0.328 to 16.404 ft	RX-RVM5		
	Diffuse reflective		Infrared	700 mm 27.559 in	RX-D700		
			Red	200 mm 7.874 in	RX-D200R		
	RX2 (DC 2-wire type)	Thru-beam		5 m 16.404 ft	RX2-M5		Non contact DC 2-wire type
Retroreflective			0.1 to 2 m (Note) 0.328 to 6.562 ft	RX2-PRVM2			
Diffuse reflective			300 mm 11.811 in	RX2-D300			
RX3 (Intelligent type)	Thru-beam		10 m 32.808 ft	RX3-M10 (Orders accepted till December, 2003)	NPN open-collector transistor		
	Retroreflective		Red (with polarizing filters)	0.1 to 3 m (Note) 0.328 to 9.843 ft		RX3-PRVM3 (Orders accepted till December, 2003)	
			For transparent object sensing	500 mm (Note) 19.685 in		RX3-PRV500 (Orders accepted till December, 2003)	
	Diffuse reflective		700 mm 27.559 in	RX3-D700 (Orders accepted till December, 2003)			
RX4 (Heavy duty type)	Thru-beam		2 m 6.562 ft cable length	5 m 16.404 ft	RX4-M5		
			3 m 9.843 ft cable length		RX4-M5-C3		
			5 m 16.404 ft cable length		RX4-M5-C5		

Note: The sensing range of the retroreflective type sensor is specified for the **RF-230** reflector. Further, the sensing range of **RX-PRVM3**, **RX-RVM5**, **RX2-PRVM2** and **RX3-PRVM3** is the possible setting range for the reflector. The sensor can detect an object less than 0.1 m 0.328 ft away.

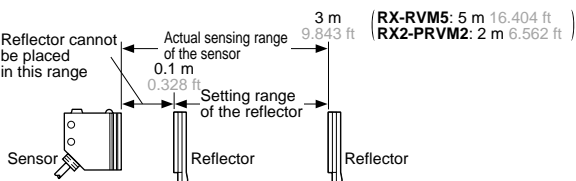

ORDER GUIDE

5 m 16.404 ft cable length type

5 m 16.404 ft cable length type (standard: 2 m 6.562 ft) is also available.

• Table of Model Nos.

		Type	Standard	5 m 16.404ft cable length type	
RX (Standard type)	Thru-beam	Infrared		RX-M10	RX-M10-C5
			Long sensing range	RX-M50	RX-M50-C5
		For mark sensing	Red	RX-M2R	RX-M2R-C5
	Green		RX-500G	_____	
	Retroreflective	Red (with polarizing filters)		RX-PRVM3	RX-PRVM3-C5
		For transparent object sensing		RX-PRV500	RX-PRV500-C5
		Infrared (long sensing range)		RX-RVM5	RX-RVM5-C5
	Diffuse reflective	Infrared		RX-D700	RX-D700-C5
		Red		RX-D200R	RX-D200R-C5
RX2 (DC 2-wire type)	Thru-beam	Infrared	RX2-M5	RX2-M5-C5	
	Retroreflective	Red (with polarizing filters)	RX2-PRVM2	RX2-PRVM2-C5	
	Diffuse reflective	Infrared	RX2-D300	RX2-D300-C5	

Accessories

- **MS-RX-1**
(Sensor mounting bracket)

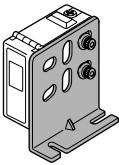

Two M4 (length 16 mm 0.630 in) hexagon-socket-head bolts are attached

- **MS-RX-2**
(Sensor mounting bracket)

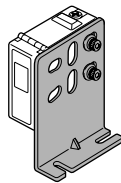

Two M4 (length 16 mm 0.630 in) hexagon-socket-head bolts are attached

- **PT-RX4-1**
(Oil resistant protective tube 1 m 3.281 ft long)
- **PT-RX4-2**
(Oil resistant protective tube 2 m 6.562 ft long)
- **PT-RX4-4**
(Oil resistant protective tube 4 m 13.123 ft long)



- **RF-230**
(Reflector)



CX-400

EX-30

EX-20

EX-10

Amplifier Built-in

EQ-20

EQ-30

RX

RX-LS200

OPTIONS

Designation	Model No.	Description			
Slit mask (For RX-M10, RX2-M5 and RX3-M10 only)	OS-RX-05 × 5 (Slit size 0.5 × 5 mm) (0.020 × 0.197 in)	Slit on emitter <ul style="list-style-type: none"> • Sensing range: 2.7 m 8.858 ft [RX-M10 and RX3-M10] 1.4 m 4.593 ft [RX2-M5] • Min. sensing object: ϕ8 mm ϕ0.315 in 			
		Slit on receiver <ul style="list-style-type: none"> • Sensing range: 1.9 m 6.234 ft [RX-M10 and RX3-M10] 1 m 3.281 ft [RX2-M5] • Min. sensing object: ϕ6 mm ϕ0.236 in 			
		Slit on both sides <ul style="list-style-type: none"> • Sensing range: 0.4 m 1.312 ft [RX-M10 and RX3-M10] 0.2 m 0.656 ft [RX2-M5] • Min. sensing object: 0.5 × 5 mm 0.020 × 0.197 in 			
	OS-RX-1 × 5 (Slit size 1 × 5 mm) (0.039 × 0.197 in)	Slit on emitter <ul style="list-style-type: none"> • Sensing range: 3.8 m 12.467 ft [RX-M10 and RX3-M10] 1.9 m 6.234 ft [RX2-M5] • Min. sensing object: ϕ8 mm ϕ0.315 in 			
		Slit on receiver <ul style="list-style-type: none"> • Sensing range: 2.8 m 9.186 ft [RX-M10 and RX3-M10] 1.4 m 4.593 ft [RX2-M5] • Min. sensing object: ϕ6 mm ϕ0.236 in 			
		Slit on both sides <ul style="list-style-type: none"> • Sensing range: 0.8 m 2.625 ft [RX-M10 and RX3-M10] 0.4 m 1.312 ft [RX2-M5] • Min. sensing object: 1 × 5 mm 0.039 × 0.197 in 			
	OS-RX-3 × 5 (Slit size 3 × 5 mm) (0.118 × 0.197 in)	Slit on emitter <ul style="list-style-type: none"> • Sensing range: 7 m 22.966 ft [RX-M10 and RX3-M10] 3.5 m 11.483 ft [RX2-M5] • Min. sensing object: ϕ8 mm ϕ0.315 in 			
		Slit on receiver <ul style="list-style-type: none"> • Sensing range: 4.9 m 16.076 ft [RX-M10 and RX3-M10] 2.5 m 8.202 ft [RX2-M5] • Min. sensing object: ϕ6 mm ϕ0.236 in 			
		Slit on both sides <ul style="list-style-type: none"> • Sensing range: 2.6 m 8.530 ft [RX-M10 and RX3-M10] 1.3 m 4.265 ft [RX2-M5] • Min. sensing object: 3 × 5 mm 0.118 × 0.197 in 			
	Reflector (For retro-reflective type sensor only)	RF-210	<ul style="list-style-type: none"> • Sensing range: 0.2 to 1.5 m 0.656 to 4.921 ft [RX-RVM5] 0.4 to 1 m 1.312 to 3.281 ft [RX-PRVM3 and RX3-PRVM3] • Min. sensing object: ϕ30 mm ϕ1.181 in 		
		RF-220	<ul style="list-style-type: none"> • Sensing range: 0.1 to 3.8 m 0.328 to 12.467 ft [RX-RVM5] 0.1 to 2 m 0.328 to 6.562 ft [RX-PRVM3 and RX3-PRVM3] 0.1 to 1.3 m 0.328 to 4.265 ft [RX2-PRVM2] 250 mm 9.843 in [RX-PRV500 and RX3-PRV500] • Min. sensing object: ϕ35 mm ϕ1.378 in 		
	Reflector mounting bracket	MS-RF21-1	Protective mounting bracket for RF-210 It protects the reflector from damage and maintains alignment.		
MS-RF22		For RF-220			
MS-RF23		For RF-230			
Reflective tape (For RX-RVM5 only)	RF-T110	This tape can be used in place of the reflector by cutting it to a suitable size. • Size: 100 × 100 mm 3.937 × 3.937 in • Sensing range: 3 m 9.843 ft (at 50 × 50 mm 1.969 × 1.969 in) (There may be a slight variation depending on the product.)			
Protective tube	PT-RX500	Length <table border="1"> <tr> <td>500 mm 19.685 in</td> <td rowspan="2">Cable is protected from external forces. It does not rust as it is made of stainless steel.</td> </tr> <tr> <td>1,000 mm 39.370 in</td> </tr> </table>	500 mm 19.685 in	Cable is protected from external forces. It does not rust as it is made of stainless steel.	1,000 mm 39.370 in
	500 mm 19.685 in		Cable is protected from external forces. It does not rust as it is made of stainless steel.		
1,000 mm 39.370 in					
PT-RX1000					
Sensor checker (Note)	CHX-SC2	It is useful for beam alignment of thru-beam type sensors. The optimum receiver position is given by indicators, as well as an audio signal.			

Note: Refer to p.414~ for details of the sensor checker **CHX-SC2**.

Slit mask

• **OS-RX-□**
Fitted on the front face of the sensor with one-touch.

★ Slit size

OS-RX-1 × 5
a b

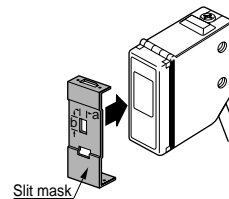

Reflector

• **RF-210**

• **RF-220**

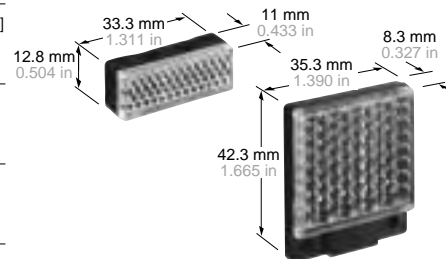

Reflector mounting bracket

• **MS-RF21-1**

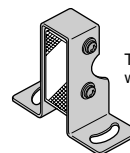

Two M3 (length 12 mm 0.472 in) screws with washers are attached.

• **MS-RF22**

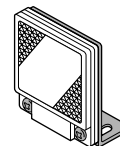

Two M3 (length 8 mm 0.315 in) screws with washers are attached.

• **MS-RF23**

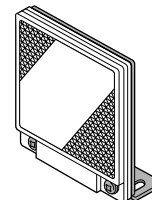

Two M4 (length 10 mm 0.394 in) screws with washers are attached.

Protective tube

• **PT-RX500**
• **PT-RX1000**

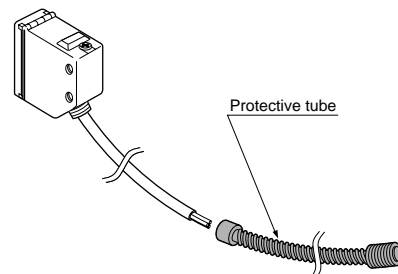

Sensor checker

• **CHX-SC2**

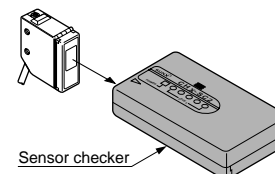

SPECIFICATIONS

Standard type

Item	Type Model No.	Thru-beam				Retroreflective			Diffuse reflective	
		Infrared		Red	Green	Red (with polarizing filters)		Infrared (Long sensing range)	Infrared	Red
		Long sensing range				For transparent object sensing				
		RX-M10	RX-M50	RX-M2R	RX-500G	RX-PRVM3	RX-PRV500	RX-RVM5	RX-D700	RX-D200R
Sensing range		10 m 32.808 ft	50 m 164.042 ft	2 m 6.562 ft	500 mm 19.685 in	0.1 to 3 m 0.328 to 9.843 ft (Note 1)	500 mm 19.685 in (Note 1)	0.1 to 5 m 0.328 to 16.404 ft (Note 1)	700 mm 27.559 in (Note 2)	200 mm 7.874 in (Note 2)
Sensing object		φ 10 mm 0.394 in or more opaque object (Note 3)				φ 50 mm φ 1.969 in or more opaque, translucent or specular object (Note 1)	φ 50 mm φ 1.969 in or more opaque, translucent or transparent object (Note 1)	φ 50 mm φ 1.969 in or more opaque, or transparent object (Note 1)	Opaque, translucent or transparent object	
Hysteresis		—				—			15 % or less of operation distance	
Repeatability (perpendicular to sensing axis)		0.5 mm 0.020 in or less				1 mm 0.039 in or less	0.2 mm 0.008 in or less	1 mm 0.039 in or less	0.5 mm 0.020 in or less	
Supply voltage		12 to 24 V DC ± 10 % Ripple P-P 10 % or less								
Current consumption		Emitter: 20 mA or less (RX-M50: 25 mA or less), Receiver: 25 mA or less				40 mA or less				
Sensing output		NPN open-collector transistor • Maximum sink current: 100 mA • Applied voltage: 30 V DC or less (between sensing output and 0 V) • Residual voltage: 1.5 V or less (at 100 mA sink current) 0.4 V or less (at 16 mA sink current)								
Utilization category		DC-12 or DC-13								
Output operation		Switchable either Light-ON or Dark-ON								
Short-circuit protection		Incorporated								
Self-diagnosis output		NPN open-collector transistor • Maximum sink current: 50 mA • Applied voltage: 30 V DC or less (between self-diagnosis output and 0 V) • Residual voltage: 1 V or less (at 50 mA sink current) 0.4 V or less (at 16 mA sink current)								
Output operation		ON under unstable sensing condition								
Short-circuit protection		—								
Response time		1 ms or less								
Test input (emission halt) function		Incorporated								
Operation indicator		Red LED (lights up when the sensing output is ON)								
Stability indicator		Green LED (lights up under stable light received condition or stable dark condition)								
Emitting indicator		Red LED (lights up during beam emission)				—				
Sensitivity adjuster		Continuously variable adjuster								
Automatic interference prevention function		—				Incorporated (Two units of sensors can be mounted close together.)				
Environmental resistance	Pollution degree	3 (Industrial environment)								
	Protection	IP67 (IEC)								
	Ambient temperature	- 25 to + 60 °C - 13 to + 140 °F (No dew condensation or icing allowed), Storage: - 30 to + 70 °C - 22 to + 158 °F								
	Ambient humidity	35 to 85 % RH, Storage: 35 to 85 % RH								
	Ambient illuminance	Sunlight: 11,000 lx at the light-receiving face, Incandescent light: 3,500 lx at the light-receiving face								
	EMC	EN 50081-2, EN 50082-2, EN 60947-5-2								
	Voltage withstandability	1,000 V AC for one min. between all supply terminals connected together and enclosure								
	Insulation resistance	20 MΩ, or more, with 250 V DC megger between all supply terminals connected together and enclosure								
Vibration resistance	10 to 500 Hz frequency, 1.5 mm 0.059 in amplitude (10 G max.) in X, Y and Z directions for two hours each									
Shock resistance	500 m/s ² acceleration (50 G approx.) in X, Y and Z directions for three times each									
Emitting element		Infrared LED (modulated)	Red LED (modulated)	Green LED (modulated)	Red LED (modulated)	Infrared LED (modulated)	Red LED (modulated)			
Material		Enclosure: Die-cast zinc alloy, Indicator cover: Polyethersulphone, Lens: Polycarbonate (retroreflective type: Acrylic)								
Cable		Emitter: 0.15 mm ² 3-core oil, heat and cold resistant cabtyre cable, 2 m 6.562 ft long Receiver: 0.15 mm ² 4-core oil, heat and cold resistant cabtyre cable, 2 m 6.562 ft long				0.15 mm ² 5-core oil, heat and cold resistant cabtyre cable, 2 m 6.562 ft long				
Cable extension		Extension up to total 100 m 328.084 ft is possible with 0.3 mm ² , or more, cable (thru-beam type: both emitter and receiver).								
Weight		Emitter: 70 g approx. (RX-M50: 75 g approx.) Receiver: 70 g approx. (RX-M50: 75 g approx.)				75 g approx.				
Accessories		MS-RX-1 (Sensor mounting bracket): 1 set for emitter and receiver Adjusting screwdriver: 1 pc.				MS-RX-1 (Sensor mounting bracket): 1 set RF-230 (Reflector): 1 pc. Adjusting screwdriver: 1 pc.			MS-RX-1 (Sensor mounting bracket): 1 set Adjusting screwdriver: 1 pc.	

- Notes: 1) The sensing range and the setting object for the retroreflective type sensor are specified for the RF-230 reflector. Further, the sensing range of RX-PRVM3 and RX-RVM5 is the possible setting range for the reflector. The sensor can detect an object less than 0.1 m 0.328 ft away.
- 2) The sensing range of the diffuse reflective type sensor is specified for white non-glossy paper (200 × 200 mm 7.874 × 7.874 in) as the object.
- 3) If slit masks (optional) are fitted on RX-M10, an object of 0.5 × 5 mm 0.020 × 0.197 in can be detected.

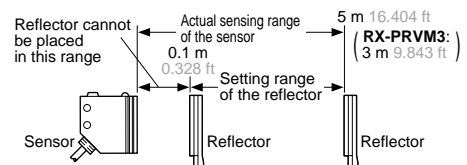

SPECIFICATIONS

DC 2-wire type

Type	Thru-beam	Retroreflective (with polarizing filters)	Diffuse reflective	
Item	Model No.	RX2-M5	RX2-PRVM2	RX2-D300
Sensing range	5 m 16.404 ft	0.1 to 2 m 0.328 to 6.562 ft (Note 1)	300 mm 11.811 in (Note 2)	
Sensing object	φ 10 mm φ 0.394 in or more opaque object (Note 3)	φ 50 mm φ 1.969 in or more opaque, translucent or specular object (Note 1)	Opaque, translucent or transparent object	
Hysteresis	—	—	15 % or less of operation distance	
Repeatability (perpendicular to sensing axis)	0.5 mm 0.020 in or less	1 mm 0.039 in or less	0.5 mm 0.020 in or less	
Supply voltage	12 to 24 V DC ± 10 % Ripple P-P 10 % or less			
Current consumption	Emitter: 8 mA or less, Receiver: 0.8 mA or less (Note 4)		1 mA or less (Note 4)	
Sensing output	Non contact DC 2-wire type • Load current: 5 to 100 mA • Residual voltage: 4 V or less (Note 5)			
Output operation	Switchable either Light-ON or Dark-ON			
Short-circuit protection	Incorporated			
Response time	3 ms or less			
Operation indicator	Red LED (lights up when the output is ON)			
Stability indicator	Green LED (Light-ON mode: lights up under stable light received condition Dark-ON mode: lights up under stable dark condition)			
Emitting indicator	Red LED (lights up during beam emission)	—		
Sensitivity adjuster	Continuously variable adjuster			
Protection	IP67 (IEC)			
Ambient temperature	- 20 to + 60 °C - 4 to + 140 °F (No dew condensation or icing allowed), Storage: - 30 to + 70 °C - 22 to + 158 °F			
Ambient humidity	35 to 85 % RH, Storage: 35 to 85 % RH			
Ambient illuminance	Sunlight: 11,000 lx at the light-receiving face, Incandescent light: 3,500 lx at the light-receiving face			
Noise immunity	Power line: 240 Vp, 10 ms cycle, and 0.5 μs pulse width; Radiation: 300 Vp, 10 ms cycle, and 0.5 μs pulse width (with noise simulator)			
Voltage withstandability	1,000 V AC for one min. between all supply terminals connected together and enclosure			
Insulation resistance	20 MΩ, or more, with 250 V DC megger between all supply terminals connected together and enclosure			
Vibration resistance	10 to 500 Hz frequency, 1.5 mm 0.059 in amplitude (10 G max.) in X, Y and Z directions for two hours each			
Shock resistance	500 m/s ² acceleration (50 G approx.) in X, Y and Z directions for three times each			
Emitting element	Infrared LED (modulated)	Red LED (modulated)	Infrared LED (modulated)	
Material	Enclosure: Die-cast zinc alloy, Indicator cover: Polyethersulphone, Lens: Polycarbonate (RX2-PRVM2: Acrylic)			
Cable	0.15 mm ² 2-core oil, heat and cold resistant cable, 2 m 6.562 ft long			
Cable extension	— (Note 5)			
Weight	Emitter: 70 g approx., Receiver: 70 g approx.	75 g approx.	70 g approx.	
Accessories	MS-RX-1 (Sensor mounting bracket): 1 set for emitter and receiver Adjusting screwdriver: 1 pc.	MS-RX-1 (Sensor mounting bracket): 1 set RF-230 (Reflector): 1 pc. Adjusting screwdriver: 1 pc.	MS-RX-1 (Sensor mounting bracket): 1 set Adjusting screwdriver: 1 pc.	

Notes: 1) The sensing range and the sensing object for **RX2-PRVM2** are specified for the **RF-230** reflector. Further, the sensing range is the possible setting range for the reflector. The sensor can detect an object less than 0.1 m 0.328 ft away.

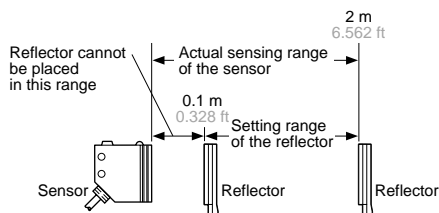

2) The sensing range of **RX2-D300** is specified for white non-glossy paper (200 × 200 mm 7.874 × 7.874 in) as the object.

3) If slit masks (optional) are fitted, an object of 0.5 × 5 mm 0.020 × 0.197 in can be detected.

4) It is the leakage current when the output is in the OFF state.

5) When extending the cable, the residual voltage will be increased depending on the type of cable used. Verify the residual voltage when extending the cable.

SPECIFICATIONS

Intelligent type (Orders accepted till December, 2003)

Item	Type	Retroreflective (with polarizing filters)			Diffuse reflective
	Model No.	Thru-beam	RX3-PRVM3	RX3-PRV500	RX3-D700
Sensing range		10 m 32.808 ft	0.1 to 3 m 0.328 to 9.843 ft (Note 1)	500 mm 19.685 in (Note 1)	700 mm 27.559 in (Note 2)
Sensing object		φ10 mm 0.394 in or more opaque object (Note 3)	φ50 mm φ1.969 in or more opaque, translucent or specular object (Note 1)	φ50 mm φ1.969 in or more opaque, translucent or transparent object (Note 1)	Opaque, translucent or transparent object
Hysteresis					15 % or less of operation distance
Repeatability (perpendicular to sensing axis)		0.5 mm 0.020 in or less	1 mm 0.039 in or less	0.2 mm 0.008 in or less	0.5 mm 0.020 in or less
Supply voltage		12 to 24 V DC ± 10 % Ripple P-P 10 % or less			
Current consumption		Emitter: 20 mA or less Receiver: 45 mA or less	50 mA or less		
Sensing output		NPN open-collector transistor • Maximum sink current: 100 mA • Applied voltage: 30 V DC or less (between sensing output and 0 V) • Residual voltage: 1.5 V or less (at 100 mA sink current) 0.4 V or less (at 16 mA sink current)			
Output operation		Switchable either Light-ON or Dark-ON			
Short-circuit protection		Incorporated			
Self-diagnosis output		NPN open-collector transistor • Maximum sink current: 50 mA • Applied voltage: 30 V DC or less (between self-diagnosis output and 0 V) • Residual voltage: 1 V or less (at 50 mA sink current) 0.4 V or less (at 16 mA sink current)			
Output operation		ON under unstable sensing or the sensor circuit failure conditions (Note 4)			
Short-circuit protection		Incorporated			
Response time		3 ms or less			
Test input (emission halt) function		Incorporated			
Operation indicator		Red LED (lights up when the sensing output is ON, blinks when the sensor circuit has failed) (Note 4)			
Stability indicator		Green LED (lights up when the sensing output wire is disconnected, lights up under stable light received condition) (Note 4)			
Emitting indicator		Red LED (lights up during beam emission)			
Sensitivity adjuster		Continuously variable adjuster			
Automatic interference prevention function		Incorporated (Two units of sensors can be mounted close together.)			
Self-diagnosis function		Self-diagnosis of incident light intensity and internal circuit failure			
Environmental resistance	Protection	IP67 (IEC)			
	Ambient temperature	- 25 to + 60 °C - 13 to + 140 °F (No dew condensation or icing allowed), Storage: - 30 to + 70 °C - 22 to + 158 °F			
	Ambient humidity	35 to 85 % RH, Storage: 35 to 85 % RH			
	Ambient illuminance	Sunlight: 11,000 lx at the light-receiving face, Incandescent light: 3,500 lx at the light-receiving face			
	Noise immunity	Power line: 240 Vp, 10 ms cycle, and 0.5 μs pulse width; Radiation: 300 Vp, 10 ms cycle, and 0.5 μs pulse width (with noise simulator)			
	Voltage withstandability	1,000 V AC for one min. between all supply terminals connected together and enclosure			
	Insulation resistance	20 MΩ, or more, with 250 V DC megger between all supply terminals connected together and enclosure			
Vibration resistance	10 to 500 Hz frequency, 1.5 mm 0.059 in amplitude (10 G max.) in X, Y and Z directions for two hours each				
Shock resistance	500 m/s ² acceleration (50 G approx.) in X, Y and Z directions for three times each				
Emitting element		Infrared LED (modulated)	Red LED (modulated)	Infrared LED (modulated)	
Material		Enclosure: Die-cast zinc alloy, Indicator cover: Polyethersulphone, Lens: Polycarbonate (retroreflective type: Acrylic)			
Cable		0.15 mm ² 5-core (thru-beam type: 4-core) oil, heat and cold resistant cable, 2 m 6.562 ft long			
Cable extension		Extension up to total 100 m 328.084 ft is possible with 0.3 mm ² , or more, cable (thru-beam type: both emitter and receiver).			
Weight		Emitter: 70 g approx., Receiver: 70 g approx.	75 g approx.		
Accessories		MS-RX-1 (Sensor mounting bracket): 1 set for emitter and receiver Adjusting screwdriver: 1 pc.	MS-RX-1 (Sensor mounting bracket): 1 set RF-230 (Reflector): 1 pc. Adjusting screwdriver: 1 pc.	MS-RX-1 (Sensor mounting bracket): 1 set Adjusting screwdriver: 1 pc.	

Notes: 1) The sensing range and the sensing object for the retroreflective type sensor are specified for the **RF-230** reflector. Further, the sensing range of **RX3-PRVM3** is the possible setting range for the reflector. The sensor can detect an object less than 0.1 m 0.328 ft away.

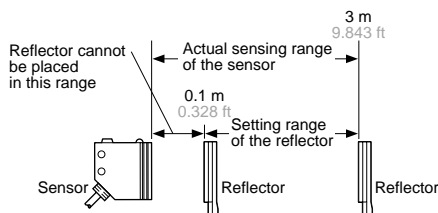

- 2) The sensing range of **RX3-D700** is specified for white non-glossy paper (200 × 200 mm 7.874 × 7.874 in) as the object.
- 3) If slit masks (optional) are fitted, an object of 0.5 × 5 mm 0.020 × 0.197 in can be detected.
- 4) Refer to p.290 for details.

SPECIFICATIONS

Heavy duty type

Item	Model No.	Thru-beam		
		Cable length 2 m 6.562 ft	Cable length 3 m 9.843 ft	Cable length 5 m 16.404 ft
Sensing range		5 m 16.404 ft		
Sensing object		ϕ 10 mm ϕ 0.394 in or more opaque object		
Repeatability (perpendicular to sensing axis)		0.5 mm 0.020 in or less		
Supply voltage		12 to 24 V DC ± 10 % Ripple P-P 10 % or less		
Current consumption		Emitter: 20 mA or less, Receiver: 25 mA or less		
Sensing output		NPN open-collector transistor <ul style="list-style-type: none"> • Maximum sink current: 100 mA • Applied voltage: 30 V DC or less (between sensing output and 0 V) • Residual voltage: 1.5 V or less (at 100 mA sink current) 0.4 V or less (at 16 mA sink current) 		
	Output operation	Switchable either Light-ON or Dark-ON		
	Short-circuit protection	Incorporated		
Self-diagnosis output		NPN open-collector transistor <ul style="list-style-type: none"> • Maximum sink current: 50 mA • Applied voltage: 30 V DC or less (between self-diagnosis output and 0 V) • Residual voltage: 1 V or less (at 50 mA sink current) 0.4 V or less (at 16 mA sink current) 		
	Output operation	ON under unstable sensing condition		
	Short-circuit protection	Incorporated		
Response time		1 ms or less		
Test input (emission halt) function		Incorporated		
Operation indicator		Red LED (lights up when the sensing output is ON)		
Stability indicator		Green LED (lights up under stable light received condition or stable dark condition)		
Emitting indicator		Red LED (lights up during beam emission)		
Sensitivity adjuster		Continuously variable adjuster		
Environmental resistance	Protection	IP67 (IEC), IP67g (JEM)		
	Ambient temperature	- 25 to + 60 °C - 13 to + 140 °F (No dew condensation or icing allowed), Storage: - 30 to + 70 °C - 22 to + 158 °F		
	Ambient humidity	35 to 85 % RH, Storage: 35 to 85 % RH		
	Ambient illuminance	Sunlight: 11,000 lx at the light-receiving face, Incandescent light: 3,500 lx at the light-receiving face		
	Noise immunity	Power line: 240 Vp, 10 ms cycle, and 0.5 μs pulse width; Radiation: 300 Vp, 10 ms cycle, and 0.5 μs pulse width (with noise simulator)		
	Voltage withstandability	1,000 V AC for one min. between all supply terminals connected together and enclosure		
	Insulation resistance	20 MΩ, or more, with 250 V DC megger between all supply terminals connected together and enclosure		
	Vibration resistance	10 to 500 Hz frequency, 1.5 mm 0.059 in amplitude (10 G max.) in X, Y and Z directions for two hours each		
Shock resistance	500 m/s ² acceleration (50 G approx.) in X, Y and Z directions for three times each			
Emitting element		Infrared LED (modulated)		
Material		Enclosure: Die-cast zinc alloy (Fluorine resin coating), Indicator cover: Polyethersulphone, Lens: Polyallylate, Protective tube sheath: Oil resistant PVC		
Cable		0.15 mm ² 4-core (emitter: 3-core) oil, heat and cold resistant cabtyre cable		
Protective tube length		1 m 3.281 ft	2 m 6.562 ft	4 m 13.123 ft
Cable extension		Extension up to total 100 m 328.084 ft is possible for both emitter and receiver with 0.3 mm ² , or more, cable.		
Weight		Emitter: 175 g approx., Receiver: 175 g approx.	Emitter: 265 g approx., Receiver: 265 g approx.	Emitter: 495 g approx., Receiver: 495 g approx.
Accessories		MS-RX-2 (Sensor mounting bracket): 1 set for emitter and receiver, Adjusting screwdriver: 1 pc.		

I/O CIRCUIT AND WIRING DIAGRAMS

RX-□ RX3-□
RX4-□

I/O circuit diagram

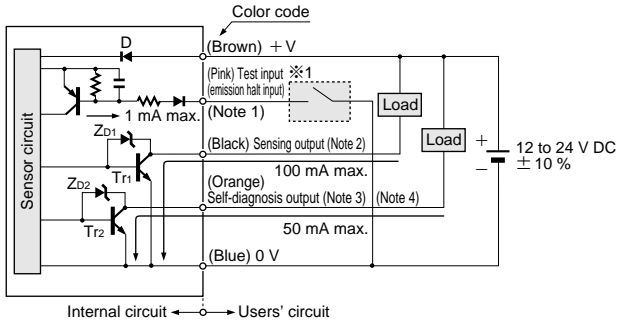

- Notes: 1) The receiver of the thru-beam type sensor does not incorporate the test input (emission halt input).
2) The emitter of the thru-beam type sensor does not incorporate the sensing output.
3) The emitter of the thru-beam type sensors **RX** and **RX4** does not incorporate the self-diagnosis output.
4) The self-diagnosis output does not incorporate a short-circuit protection circuit. Do not connect it directly to a power supply or a capacitive load.

Symbols ... D: Reverse supply polarity protection diode
ZD1, ZD2: Surge absorption zener diode
Tr1, Tr2 : NPN output transistor

Wiring diagram

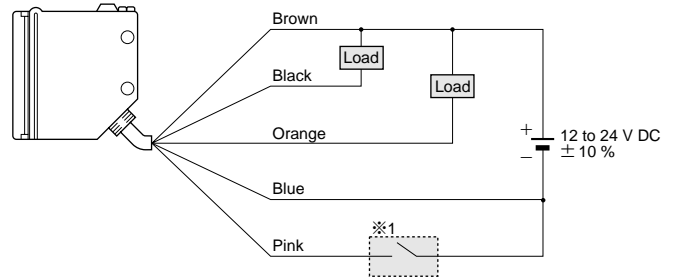

※1

Non-voltage contact or NPN open-collector transistor

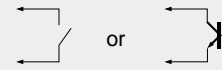

- Test input (emission halt input)
[Supply voltage - 2.5 V] or more (4.5 V or more for the **RX3** model): Emission
[Supply voltage - 3.3 V] or less (2.5 V or less for the **RX3** model): Emission halt

RX2-□

I/O circuit diagram

Emitter of thru-beam type sensor

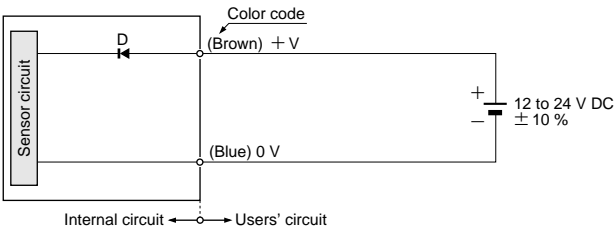

Wiring diagrams

Emitter of thru-beam type sensor

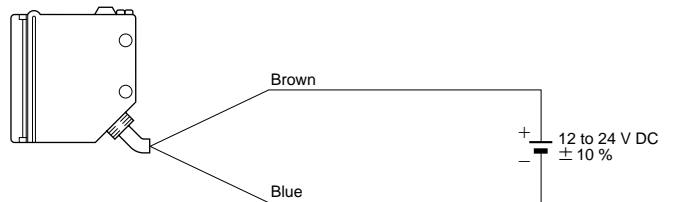

Receiver of thru-beam type sensor, retroreflective and diffuse reflective type sensors

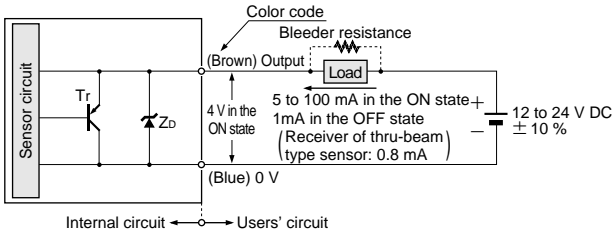

Receiver of thru-beam type sensor, retroreflective and diffuse reflective type sensors

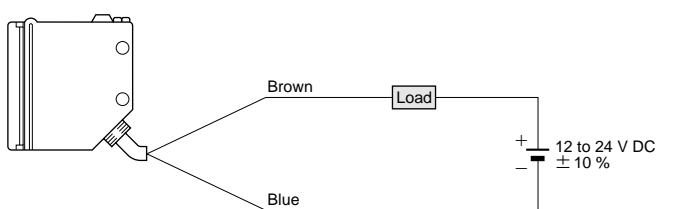

Symbols ... D : Reverse supply polarity protection diode
ZD: Surge absorption zener diode
Tr: PNP output transistor

Conditions for the load

- 1) The load should not be actuated by the leakage current (1 mA; 0.8 mA for receiver of thru-beam type sensor) in the OFF state.
- 2) The load should be actuated by (supply voltage - 4 V) in the ON state.
- 3) The current in the ON state should be between 5 to 100 mA DC.
(In case the current is less than 5 mA, connect a bleeder resistance in parallel to the load (shown in dotted line above) so that a current of 5 mA, or more, flows.)

SENSING CHARACTERISTICS (TYPICAL)

RX-□ All models

Correlation between setting distance and excess gain

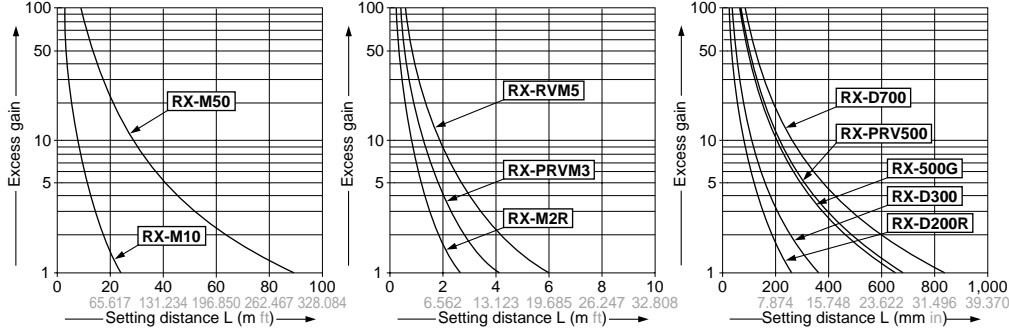

RX-M10
RX3-M10 Thru-beam type

Parallel deviation

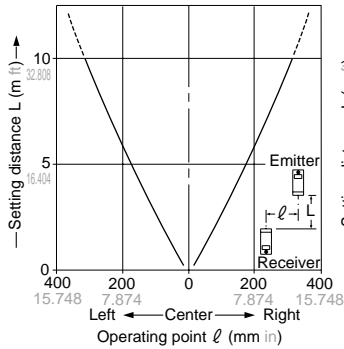

Angular deviation

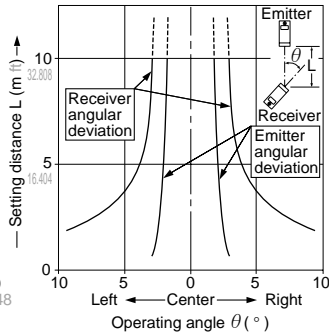

Parallel deviation with slit masks (0.5 x 5 mm 0.020 x 0.197 in)

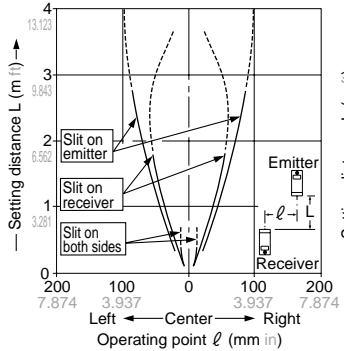

Parallel deviation with slit masks (1 x 5 mm 0.039 x 0.197 in)

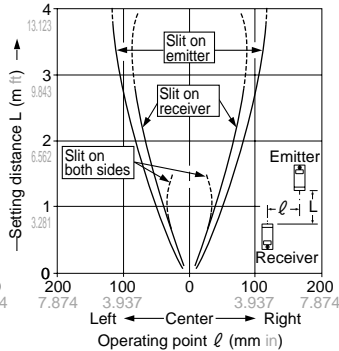

Parallel deviation with slit masks (3 x 5 mm 0.118 x 0.197 in)

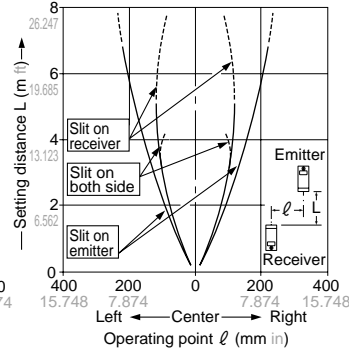

RX-M50 Thru-beam type

Parallel deviation

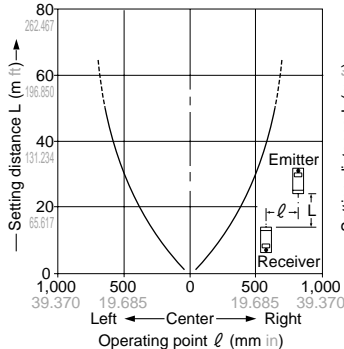

Angular deviation

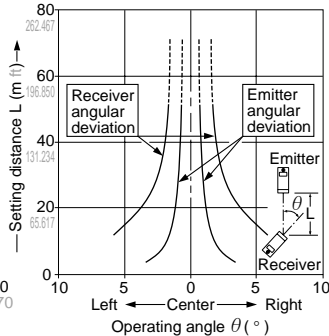

RX-M2R Thru-beam type

Parallel deviation

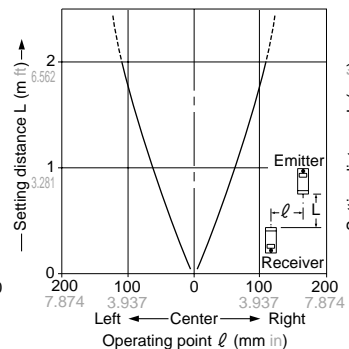

Angular deviation

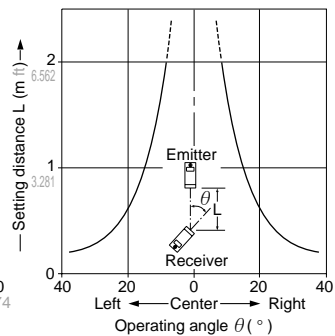

SENSING CHARACTERISTICS (TYPICAL)

RX-500G

Thru-beam type

Parallel deviation

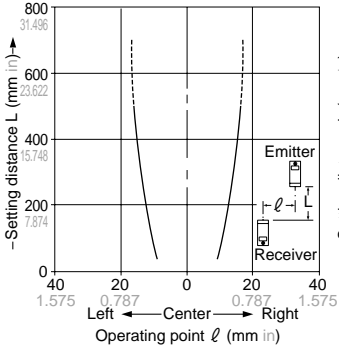

Angular deviation

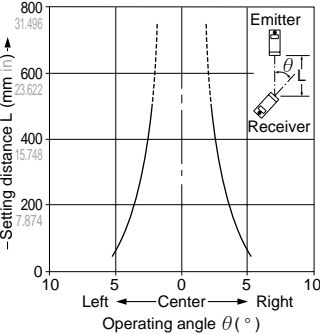

RX4-M5

Thru-beam type

Parallel deviation

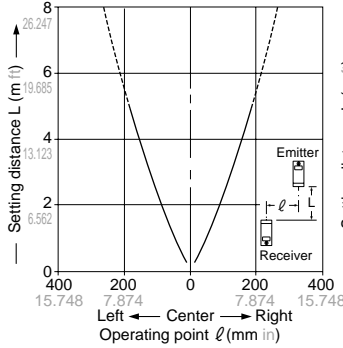

Angular deviation

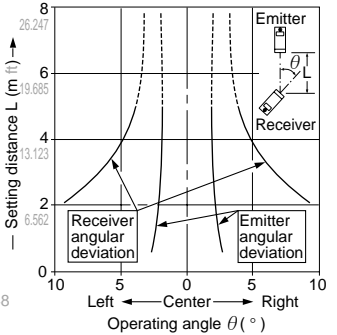

RX2-M5

Thru-beam type

Parallel deviation

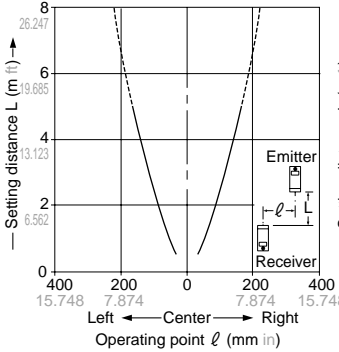

Angular deviation

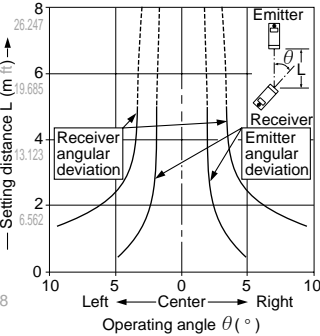

Parallel deviation with slit masks (0.5 X 5 mm 0.020 X 0.197 in)

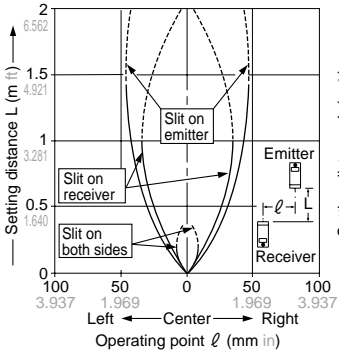

Parallel deviation with slit masks (1 X 5 mm 0.039 X 0.197 in)

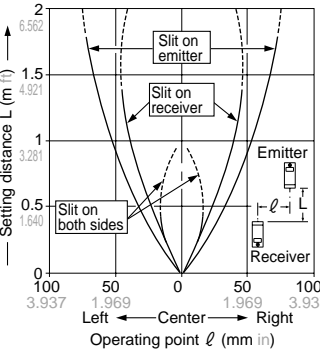

Parallel deviation with slit masks (3 X 5 mm 0.118 X 0.197 in)

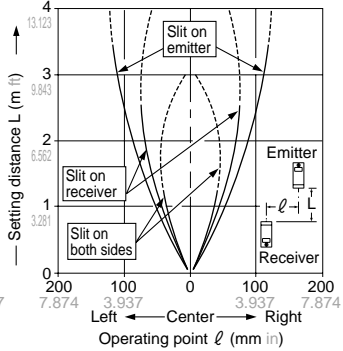

**RX-PRVM3
RX3-PRVM3**

Retroreflective type

Parallel deviation

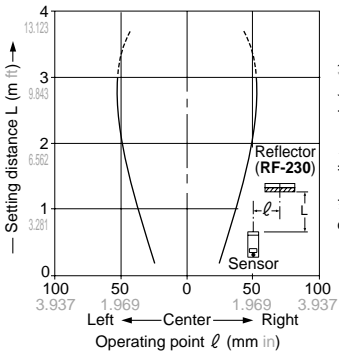

Angular deviation

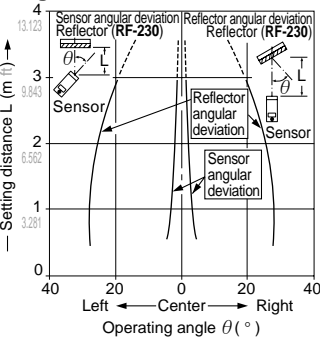

**RX-PRV500
RX3-PRV500**

Retroreflective type

Parallel deviation

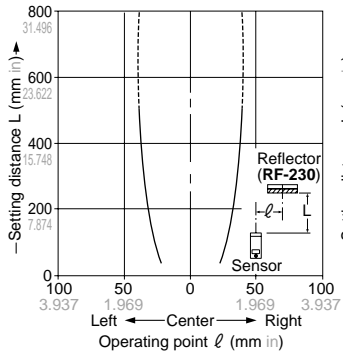

Angular deviation

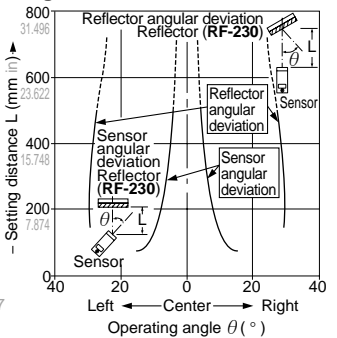

RX

SENSING CHARACTERISTICS (TYPICAL)

RX-RVM5 Retroreflective type

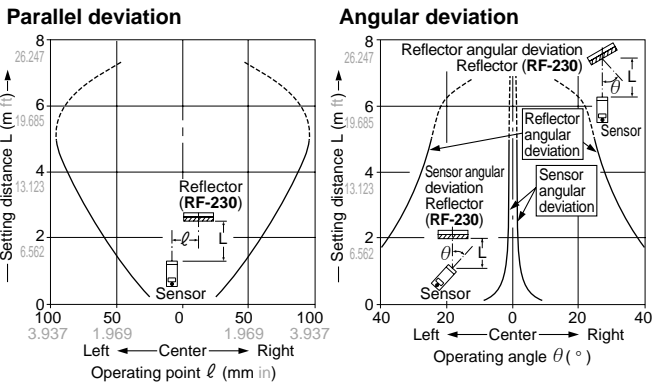

RX2-PRVM2 Retroreflective type

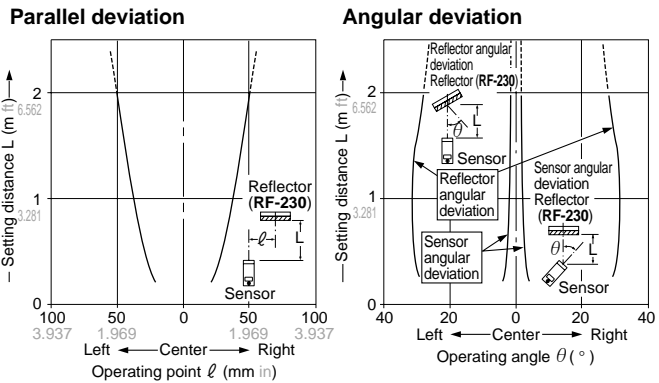

RX-D700 RX3-D700 Diffuse reflective type

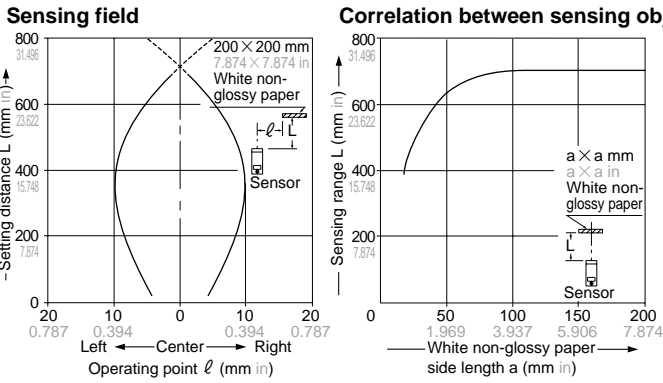

As the sensing object size becomes smaller than the standard size (white non-glossy paper 200 × 200 mm 7.874 × 7.874 in), the sensing range shortens, as shown in the left graph.

(For plotting the left graph, the sensitivity has been set such that a 200 × 200 mm 7.874 × 7.874 in white non-glossy paper is just detectable at a distance of 700 mm 27.559 in.)

RX-D200R Diffuse reflective type

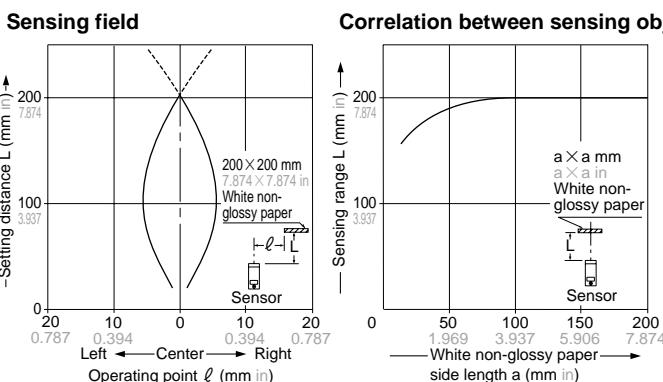

As the sensing object size becomes smaller than the standard size (white non-glossy paper 200 × 200 mm 7.874 × 7.874 in), the sensing range shortens, as shown in the left graph.

(For plotting the left graph, the sensitivity has been set such that a 200 × 200 mm 7.874 × 7.874 in white non-glossy paper is just detectable at a distance of 200 mm 7.874 in.)

RX2-D300 Diffuse reflective type

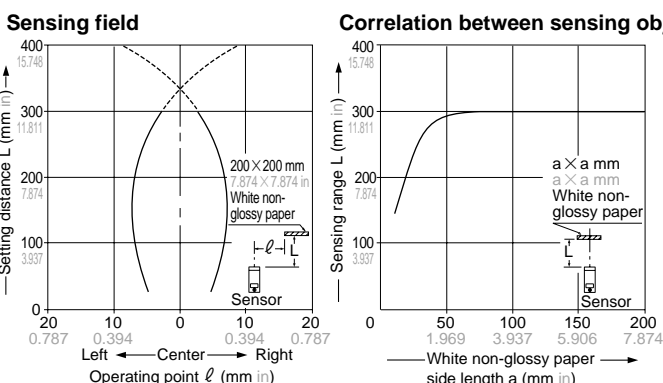

As the sensing object size becomes smaller than the standard size (white non-glossy paper 200 × 200 mm 7.874 × 7.874 in), the sensing range shortens, as shown in the left graph.

(For plotting the left graph, the sensitivity has been set such that a 200 × 200 mm 7.874 × 7.874 in white non-glossy paper is just detectable at a distance of 300 mm 11.811 in.)

PRECAUTIONS FOR PROPER USE

Refer to p.1135~ for general precautions.

All models

 This product is not a safety sensor. Its use is not intended or designed to protect life and prevent body injury or property damage from dangerous parts of machinery. It is a normal object detection sensor.

Mounting

- The tightening torque should be 1.17 N·m or less.

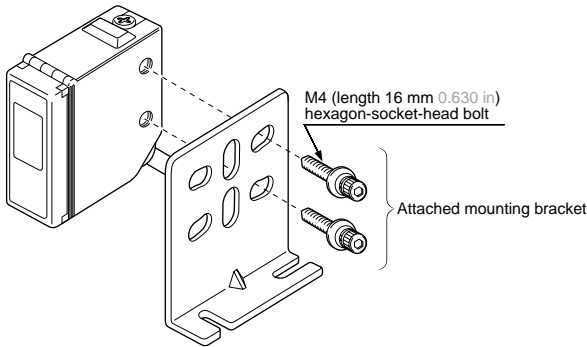

Wiring

- The self-diagnosis output does not incorporate a short-circuit protection circuit. Do not connect it directly to a power supply or a capacitive load.

Others

- Do not use during the initial transient time (50 ms) after the power supply is switched on.

RX-RVM5

Glossy object sensing

- Please take care of the following points when detecting materials having a gloss.
 - ① Make L, shown in the diagram, sufficiently long.
 - ② Install at an angle of 10 to 30 degrees to the sensing object.

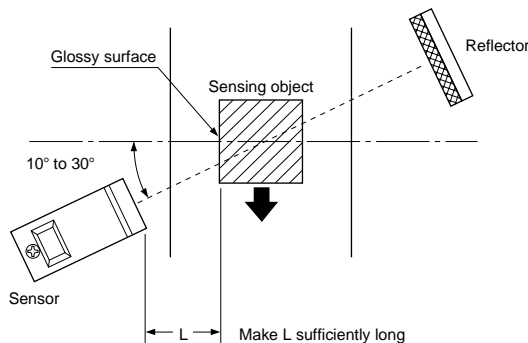

**RX□-PRVM3 RX□-PRV50
RX2-PRVM2**

Retroreflective type sensor with polarizing filters

- If a shiny object is covered or wrapped with a transparent film such as those described below, the retroreflective type sensor with polarizing filters may not be able to detect it. In that case, follow the steps given below.

Example of sensing objects

- Can wrapped by clear film
- Aluminum sheet covered by plastic film
- Gold or silver color (specular) label or wrapping paper

Steps

- Tilt the sensor with respect to the sensing object while fitting.
- Reduce the sensitivity.
- Increase the distance between the sensor and the sensing object.

RX2-□

Wiring

- Always connect the sensor to the power supply through a load. If the sensor is connected to the power supply directly, the short-circuit protection makes the sensor inoperable (The output stays in the OFF state and no indicator lights up). If this happens, connect the sensor to the power supply through a load. Further, note that the sensor will be damaged if the power supply is connected in reverse without a load.

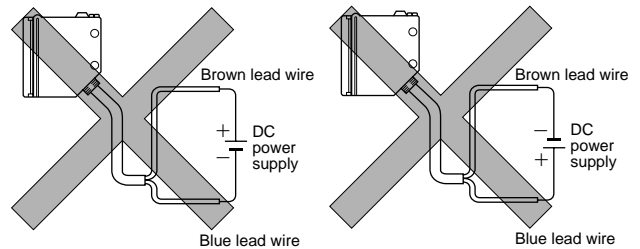

- Do not connect sensors in series (AND circuit).

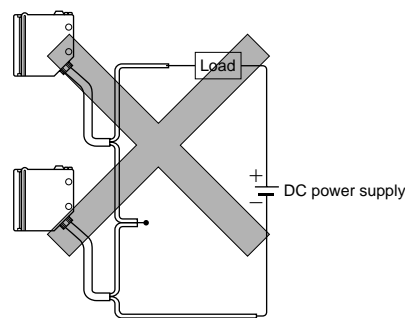

- The residual voltage of the sensor is 4 V. Before connecting to a relay, be aware of the actuation voltage of the relay. (Not all 12 V relays may be connected as the load.)

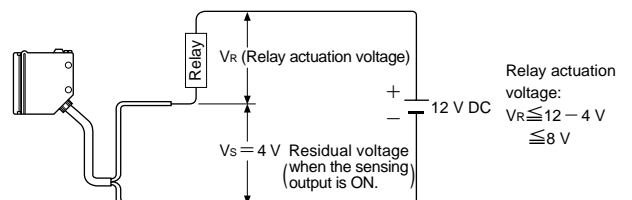

PRECAUTIONS FOR PROPER USE

Refer to p.1135~ for general precautions.

RX3-□

Self-diagnosis output

- The self-diagnosis output turns ON when the incident light intensity is reduced due to the lens being soiled with dust or dirt, due to beam misalignment, or if the internal circuit has failed. If the self-diagnosis output and the operation indicator behave as given in the table below, error is indicated and should be rectified.

Operation of each part			Failure	Corrective action
Self-diagnosis output	Operation indicator (Red LED)	Stability indicator (Green LED)		
ON	Blinking pattern ① (Note 1)	Lights off	Sensing output wire is disconnected during unstable light received condition or unstable dark condition.	Check the sensing output wire (black lead wire) and the placement of the sensor.
		Lights up	Failure of the sensor circuit. (Failure of the emitting or receiving elements, emitting circuit, amplifier circuit, or output transistor.)	If the sensor does not operate after the power is supplied once again, please contact our office.
	Blinking pattern ② (Note 1)	Lights up / Lights off	Sensing output wire is disconnected.	Check the sensing output wire (black lead wire).
	Lights up / Lights off	Lights up / Lights off	Sensing output is short-circuited and excessive current flows.	Check the sensing output wire (black lead wire) and the load.
	Lights up / Lights off	Blinking pattern ② (Note 1)	Unstable sensing condition due to soiled lens or beam misalignment. (Note 2)	Check the placement of the sensors and the surface condition of the lenses.

Notes:

- There are two blinking patterns of the operation indicator and the stability indicator.

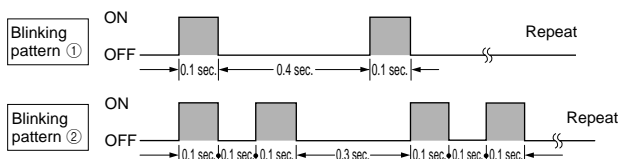

- The time chart for unstable light received condition and unstable dark condition are shown in the following diagram.

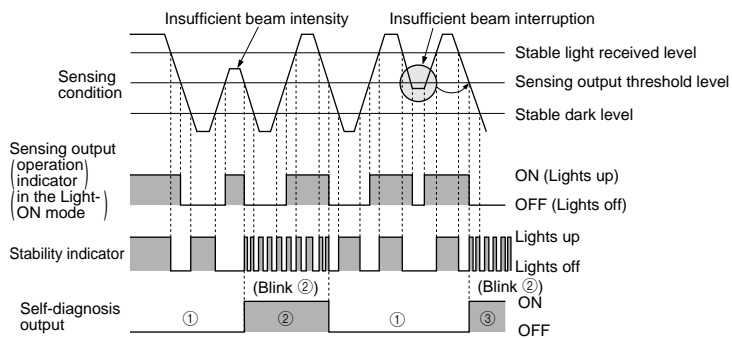

- The self-diagnosis output transistor stays in the 'OFF' state during stable sensing.
- When the sensing output changes, if the incident light intensity does not reach the stable light received level or the stable dark level, the self-diagnosis output becomes ON. Further, the self-diagnosis output changes state when the sensing output changes from Light to Dark state. (It is not affected by the operation mode switch.)
- In case of insufficient beam interruption, there will be a time lag before the self-diagnosis output turns ON.
- For the emitter of the thru-beam type diagnosis is only for the emitting element and circuit failure, and the failure is indicated by blinking pattern ①.
- The self-diagnosis output (for sensing output wire disconnection, output transistor failure) may not be generated or changed depending on the fault conditions.
- When the test input is connected to 0 V, the self-diagnosis is inoperable.
- Turning the sensitivity adjuster to the minimum simulates the internal circuit failure condition. Set it at the proper position.

PRECAUTIONS FOR PROPER USE

Refer to p.1135~ for general precautions.

RX4-□

Connection of protective tube connector

- Connect the junction connector securely as shown below. The tightening torque should be 0.98 N·m or less.

When mounted on a plate

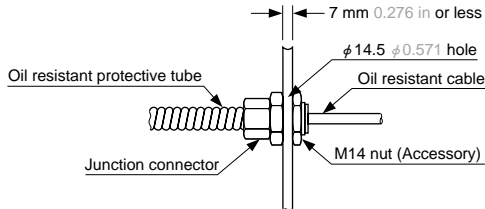

When mounted with a female screw

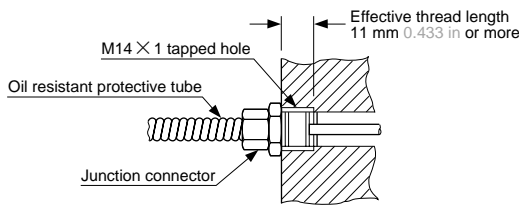

When connected to another protective tube

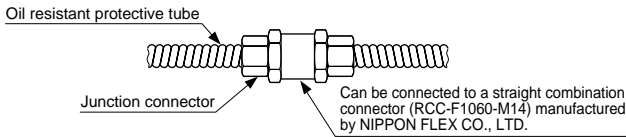

**RX-□
RX4-□**

Self-diagnosis function

- The sensor diagnoses the incident light intensity, and if it is reduced due to dirt or dust, or beam misalignment an output is generated.

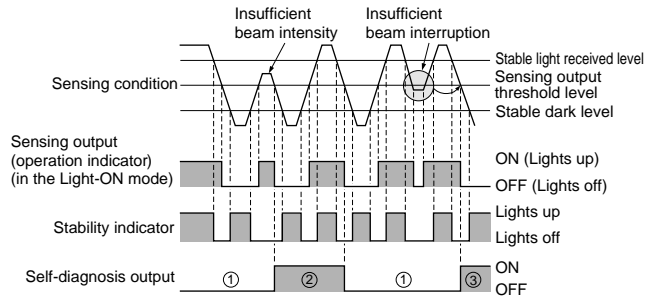

- ① The self-diagnosis output transistor stays in the 'OFF' state during stable sensing.
- ② When the sensing output changes, if the incident light intensity does not reach the stable light received level or the stable dark level, the self-diagnosis output becomes ON. Further, the self-diagnosis output changes state when the sensing output changes from Light to Dark state. (It is not affected by the operation mode switch.)
- ③ In case of insufficient beam interruption, there will be a time lag before the self-diagnosis output turns ON.

DIMENSIONS (Unit: mm in)

The CAD data in the dimensions can be downloaded from the SUNX website: <http://www.sunx.co.jp/>

**RX-M10 RX-M2R RX-500G
RX2-M5 RX3-M10**

Sensor

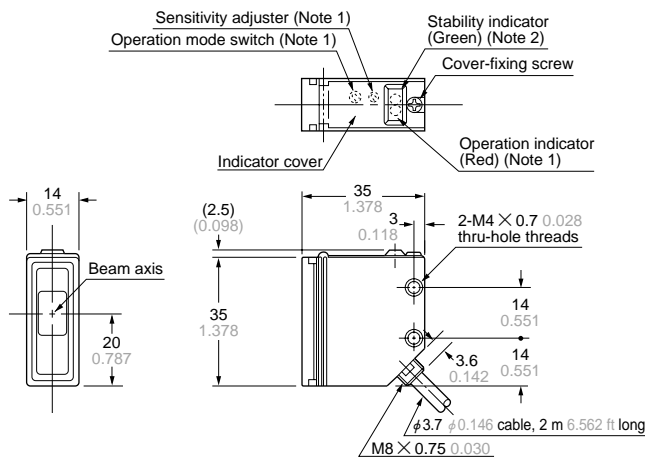

- Notes: 1) Not incorporated on the emitter.
2) It is the emitting indicator (red) on the emitter of the thru-beam type sensor.

RX-M50

Sensor

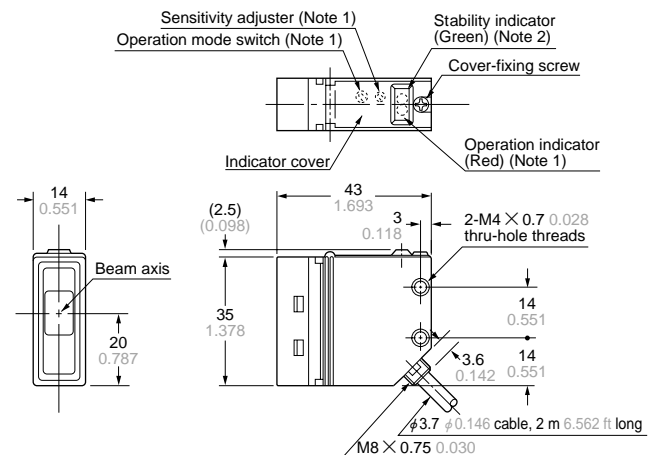

- Notes: 1) Not incorporated on the emitter.
2) It is the emitting indicator (red) on the emitter of the thru-beam type sensor.

DIMENSIONS (Unit: mm in) The CAD data in the dimensions can be downloaded from the SUNX website: <http://www.sunx.co.jp/>

MS-RX-1 Sensor mounting bracket (Accessory for RX-□, RX2-□, RX3-□)

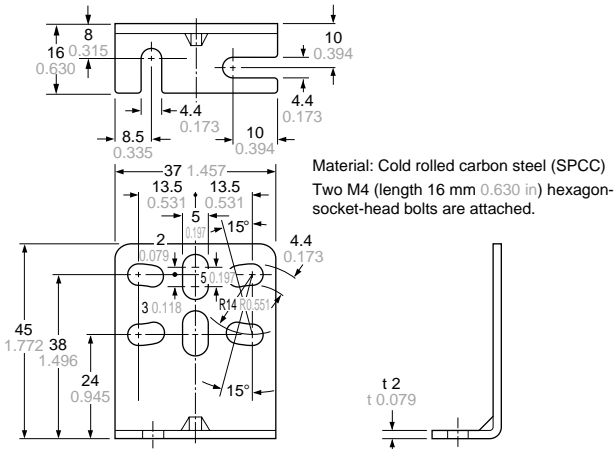

Assembly dimensions
Mounting drawing with RX-D700

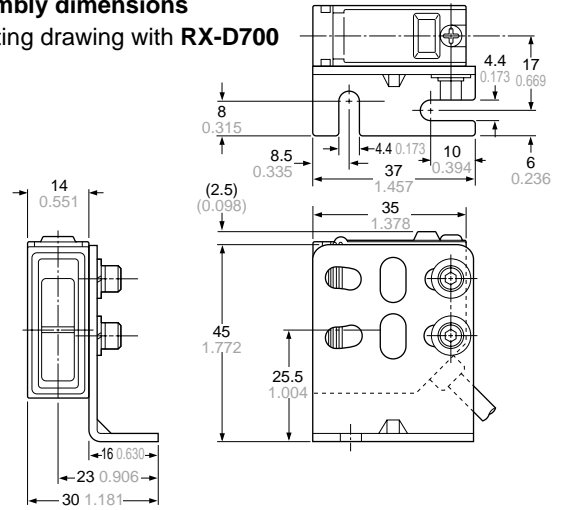

MS-RX-2 Sensor mounting bracket (Accessory for RX4-□)

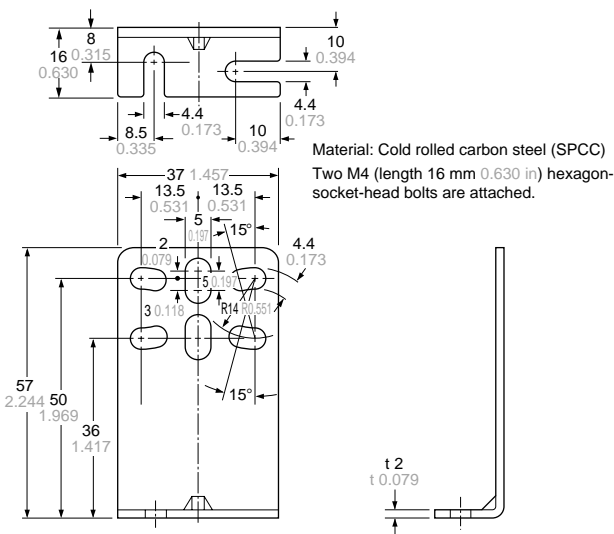

Assembly dimensions
Mounting drawing with RX4-M5

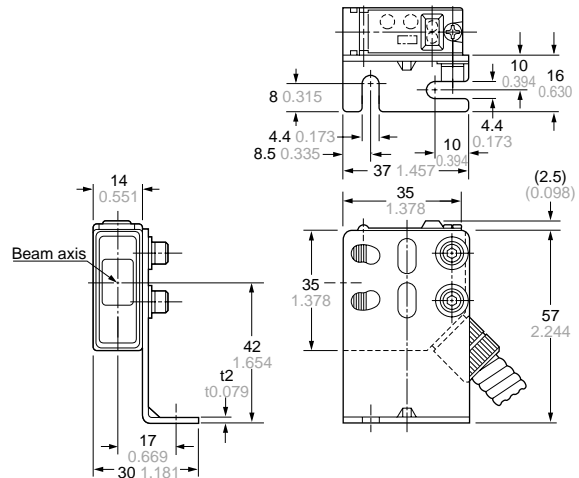

MS-RF21-1 Reflector mounting bracket for RF-210 (Optional)

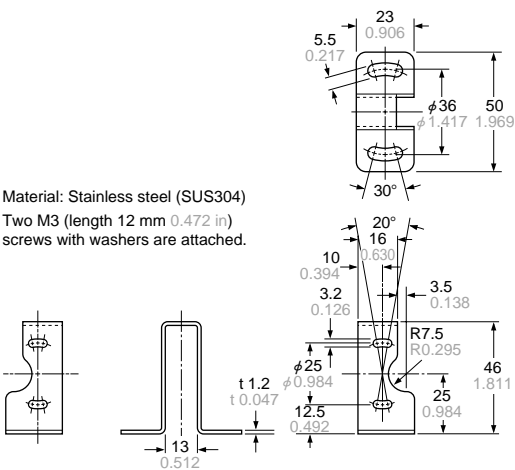

Assembly dimensions

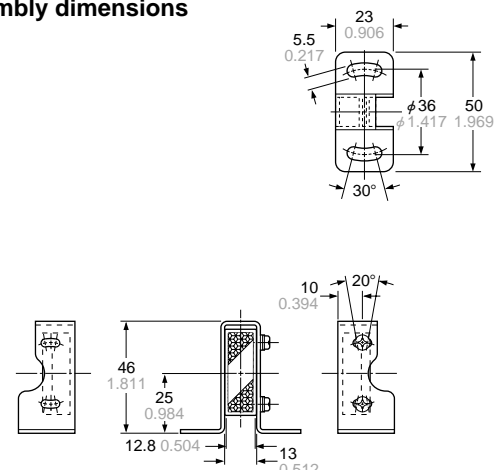

DIMENSIONS (Unit: mm in) The CAD data in the dimensions can be downloaded from the SUNX website: <http://www.sunx.co.jp/>

MS-RF22 Reflector mounting bracket for RF-220 (Optional)

Assembly dimensions

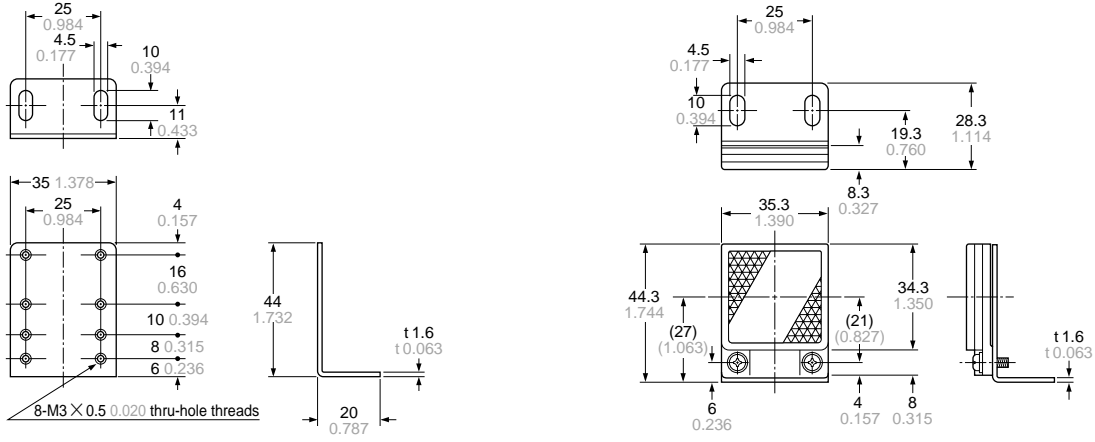

Material: Cold rolled carbon steel (SPCC)
(Uni-chrome plated)
Two M3 (Length 8 mm 0.315 in) screws with washers are attached.

MS-RF23 Reflector mounting bracket for RF-230 (Optional)

Assembly dimensions

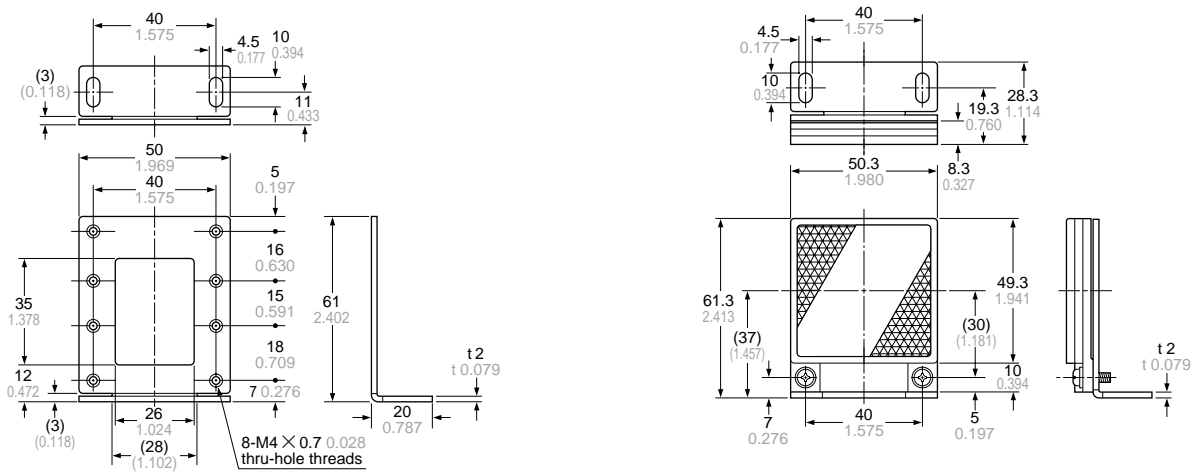

Material: Cold rolled carbon steel (SPCC)
(Uni-chrome plated)
Two M4 (Length 10 mm 0.394 in) screws with washers are attached.

PT-RX500
PT-RX1000 Protective tube (Optional)

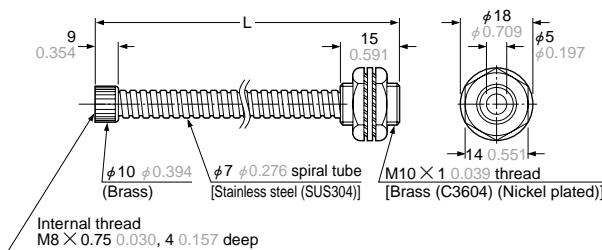

· Length L

Model No.	L (mm in)	
PT-RX500	500 +10/0	19.685 +0.394/0
PT-RX1000	1,000 +10/0	39.370 +0.394/0