

SF1-F SERIES

20 mm 0.787 in Beam Pitch Individual Beam Output Area Sensor



Individual beam outputs for a variety of applications

Refer to p.419~ for the light curtain.

Individual beam sensing

Each beam channel can generate a corresponding output. The SF1-F series can be used for discriminating the size of traveling objects, or for sensing their position.

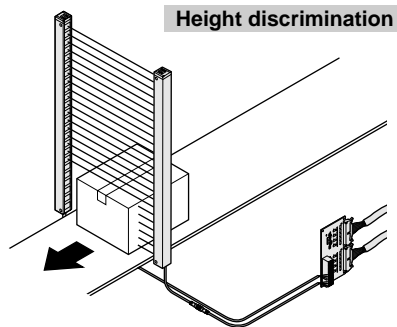

Height discrimination

20 mm 0.787 in beam pitch

A narrow 20 mm 0.787 in beam pitch, half of a conventional type, offers high sensing performance. It is able to detect a minimum $\phi 30$ mm $\phi 1.181$ in opaque object.

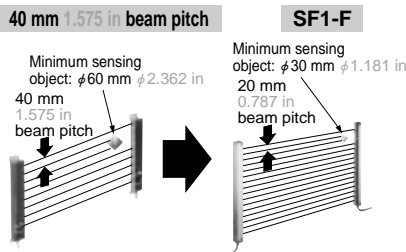

Space-saving slim size

The SF1-F series is reduced in volume, having only 2/5 times the cross-section area of the conventional model.

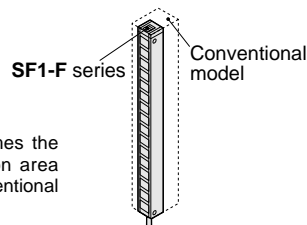

Only 2/5 times the cross-section area of the conventional model.

Wide variation

There are eight types of sensors having a sensing height from 140 mm 5.512 in (8 beam channels) to 1,260 mm 49.606 in (64 beam channels).

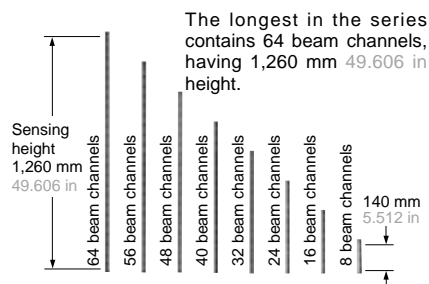

The longest in the series contains 64 beam channels, having 1,260 mm 49.606 in height.

Long sensing range: 7 m 22.966 ft

It has a long sensing range of 7 m 22.966 ft. Hence, it can detect a wide area of maximum 1,260 mm 49.606 in X 7 m 22.966 ft.

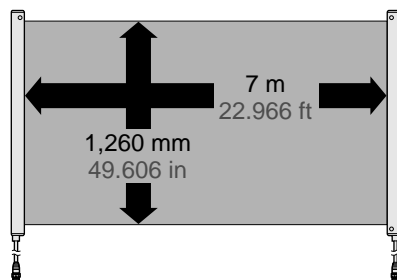

Convenient functions

Channel-check function

When the channel-check input is connected to 0V, the emission of each channel is stopped successively, one at a time. At this time, the corresponding receiver channels generate an output. This is extremely useful for a start-up check.

Interference prevention function

It prevents interference between two sensors installed close to each other. Use this function in applications, such as discriminating object size or sensing position of moving objects, where two sensors are mounted adjacently.

APPLICATIONS

Discriminating object size

Height discrimination

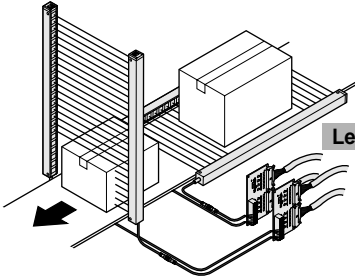

Length discrimination

Sensing moving object position

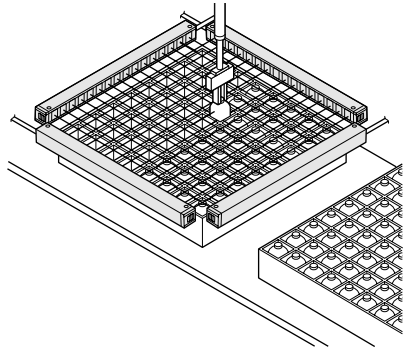

WARNING Never use this product in any personnel safety application.

ORDER GUIDE

Sensors Mating cable is not supplied with the sensor. Please order it separately.

Type	Appearance	Sensing range	Model No.	Number of beam channels	Sensing height (mm in)	Data output
Area sensor		7 m 22.966 ft	SF1-F8	8	140 5.512	Complementary voltage-driver output • Output format: Serial
			SF1-F16	16	300 11.811	
			SF1-F24	24	460 18.110	
			SF1-F32	32	620 24.409	
			SF1-F40	40	780 30.709	
			SF1-F48	48	940 37.008	
			SF1-F56	56	1,100 43.307	
			SF1-F64	64	1,260 49.606	

Control board

Appearance	Model No.	Individual beam output
	SF1-F64CB	NPN open-collector transistor

Mating cables Mating cable is not supplied with the sensor. Please order it separately.

Appearance	Model No.	Description
	SF1-CC3A	Length: 3 m 9.843 ft Weight: 600 g approx (two cables). 0.5 mm ² 4-core cable, with connector on one end, two cables per set. Cable outer diameter: ϕ 7 mm ϕ 0.276 in
	SF1-CC7A	Length: 7 m 22.966 ft Weight: 950 g approx (two cables). Connector outer diameter: ϕ 14 mm ϕ 0.551 in max. Cable color: Gray (for emitter) Gray with black line (for receiver)

SF1-F

ORDER GUIDE

Accessory

- MS-SF1-1 (Sensor mounting bracket)

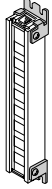

Four bracket set
 Four M6 (length 40 mm 1.575 in) truss head screws, four nuts, and four spring washers are attached.

• Front covers

Applicable beam channels		8 beam channels	16 beam channels	24 beam channels	32 beam channels	40 beam channels	48 beam channels	56 beam channels	64 beam channels
Designation	Model No.	FC-SF1-8	FC-SF1-16	FC-SF1-24	FC-SF1-32	FC-SF1-40	FC-SF1-48	FC-SF1-56	FC-SF1-64

Note: The model Nos. given above denote a single unit, not a pair of units.

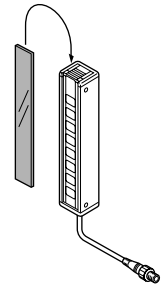

OPTIONS

Designation	Model No.	Description
Sensor mounting bracket	MS-SF1-P	It consists of one set of two brackets each for the emitter and the receiver.

Sensor mounting bracket • MS-SF1-P

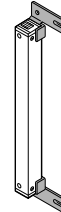

Applicable beam channels		8 beam channels	16 beam channels	24 beam channels	32 beam channels	40 beam channels	48 beam channels	56 beam channels	64 beam channels
Designation	Model No.	OS-SF1-8	OS-SF1-16	OS-SF1-24	OS-SF1-32	OS-SF1-40	OS-SF1-48	OS-SF1-56	OS-SF1-64

Note: The model Nos. given above denote a single unit, not a pair of units.

Slit mask • OS-SF1-□

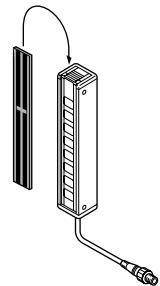

The slit mask restrains the amount of beam emitted or received and hence reduces the interference between neighbouring sensors. It is also used in cases when the beam intensity is too strong penetrating through the sensing object. Replace the original front cover with the slit mask. However, the sensing range reduces when the slit mask is used.

Sensing range

- Slit on emitter side : 3 m
9.843 ft
- Slit on receiver side : 2.6 m
8.530 ft
- Slit on both sides : 1.2 m
3.937 ft

SPECIFICATIONS

Sensors

		Number of beam channels							
		8	16	24	32	40	48	56	64
Item	Model No.	SF1-F8	SF1-F16	SF1-F24	SF1-F32	SF1-F40	SF1-F48	SF1-F56	SF1-F64
Applicable control board		SF1-F64CB							
Sensing height		140 mm 5.512 in	300 mm 11.811 in	460 mm 18.110 in	620 mm 24.409 in	780 mm 30.709 in	940 mm 37.008 in	1,100 mm 43.307 in	1,260 mm 49.606 in
Sensing range		7 m 22.966 ft							
Beam pitch		20 mm 0.787 in							
Sensing object		φ 30 mm φ 1.181 in or more opaque object (φ 35 mm φ 1.378 in or more opaque object if the setting distance is less than 0.5 m 1.640 ft.)							
Supply voltage		24 V DC ± 10 % Ripple P-P 10 % or less							
Current consumption		Emitter: 55 mA or less Receiver: 60 mA or less		Emitter: 70 mA or less Receiver: 75 mA or less		Emitter: 85 mA or less Receiver: 90 mA or less		Emitter: 100 mA or less Receiver: 105 mA or less	
Data output		Complementary voltage-driver output • Output format: Serial • Output voltage: High ... (Supply voltage – 2.5 V) or more Low ... 1.5 V or less • Maximum load current: 100 mA							
Response time		10 ms or less							
Indicators	Emitter	Emitting indicator: Green LED (lights up under normal emission, blinks under emitting circuit failure)							
	Receiver (Note)	Power indicator: Green LED (lights up when the sensor works normally) Error indicator: Yellow LED / Red LED (blink alternately when the synchronization wire breaks or the emitting circuit fails) ※The three color indicators blink in rotation when the receiving circuit fails.							
Channel-check function		Incorporated							
Interference prevention function		Incorporated (Two units of sensors can be mounted close together.)							
Environmental resistance	Protection	IP65 (IEC)							
	Ambient temperature	– 10 to + 55 °C + 14 to + 131 °F (No dew condensation or icing allowed), Storage: – 10 to + 70 °C + 14 to + 158 °F							
	Ambient humidity	35 to 85 % RH, Storage: 35 to 85 % RH							
	Ambient illuminance	Sunlight: 20,000 lx at the light-receiving face, Incandescent light: 3,500 lx at the light-receiving face							
	Noise immunity	Power line: 240 Vp, 10 ms cycle, and 0.5 μs pulse width Radiation: 300 Vp, 10 ms cycle, and 0.5 μs pulse width (with noise simulator)							
	Voltage withstandability	1,000 V AC for one min. between all supply terminals connected together and enclosure							
	Insulation resistance	20 MΩ, or more, with 500 V DC megger between all supply terminals connected together and enclosure							
	Vibration resistance	10 to 55 Hz frequency, 1.5 mm 0.059 in amplitude in X, Y and Z directions for two hours each							
Shock resistance		100 m/s ² acceleration (10 G approx.) in X, Y and Z directions for three times each							
Emitting element		Infrared LED (modulated)							
Material		Protection enclosure: Aluminum, Unit case: ABS, Front cover: Acrylic, Lens: Acrylic							
Cable		0.5 mm ² 4-core cabtyre cable, 0.5 m 1.640 ft long with a round connector at the end ※Use together with the optional mating cable							
Cable extension		Extension up to total 20 m 65.617 ft is possible, for both emitter and receiver, with 0.5 mm ² , or more, cable.							
Weight (Total of emitter and receiver)		520 g approx.	840 g approx.	1,180 g approx.	1,520 g approx.	1,840 g approx.	2,180 g approx.	2,520 g approx.	2,860 g approx.
Accessory		MS-SF1-1 (Sensor mounting bracket): 1 set for emitter and receiver							

Note: The receiver is not equipped with an incident beam indicator. In case of beam alignment, please confirm the operation from the output indicator of the control board (SF1-F64CB).

SPECIFICATIONS

Control board

Model No.		SF1-F64CB
Item		SF1-F□
Applicable sensors		SF1-F□
Supply voltage		24 V DC \pm 10 % Ripple P-P 10 % or less, Warm-up time: 500 ms or less
Current consumption		300 mA or less (including the sensor)
Individual beam outputs		NPN open-collector transistor <ul style="list-style-type: none"> • Maximum sink current: 50 mA • Applied voltage: 30 V DC or less (between individual beam output and 0 V) • Residual voltage: 1.1 V or less (at 50 mA sink current)
	Number of channels	64 channels
	Output operation	Light-ON (Note 1)
	Connector	Two 40-pin head connectors for a 2.54 mm 0.100 in pitch flat cable Conforming to MIL-C-83503 (Note 2)
Response time		20 ms or less (including the sensor's response time)
Input (External, Interference prevention / Channel-check)		Input voltage: 30 V DC or less Input impedance: 5 k Ω approx.
Indicators		Power indicator: Red LED (lights up when the power is ON) Sensor operation indicator: Green LED (lights up when the sensor works normally) Output indicators: Red LED \times 64 (each lights up when the output is ON)
Environmental resistance	Ambient temperature	- 10 to + 55 °C + 14 to + 131 °F (No dew condensation or icing allowed), Storage: - 10 to + 70 °C + 14 to + 158 °F
	Ambient humidity	35 to 85 % RH, Storage: 35 to 85 % RH
	Noise immunity	Power line: 240 Vp, 10 ms cycle, and 0.5 μ s pulse width (with noise simulator)
	Vibration resistance	10 to 55 Hz frequency, 0.75 mm 0.030 in amplitude in X, Y and Z directions for two hours each
	Shock resistance	100 m/s ² acceleration (10 G approx.) in X, Y and Z directions for three times each
Weight		200 g approx.

Notes: 1) Individual outputs not assigned to any beam channel stay at 'OFF'.

2) Please procure the connector and the connector attached cable for connection to the individual beam outputs.

- Recommended connector: AXM140415A [manufactured by Matsushita Electric Works, Ltd]
HIF3BA-40D-2.54R [manufactured by Hirose Electric CO., LTD]
or other equivalents
- Recommended connector attached cable: AYT5140□ (40-pin connector-40-pin connector) [manufactured by Matsushita Electric Works, Ltd]
AYT5840□ (40-pin connector-40 wires) [manufactured by Matsushita Electric Works, Ltd]
or equivalent

I/O CIRCUIT AND WIRING DIAGRAMS

SF1-F Sensor

I/O circuit diagram

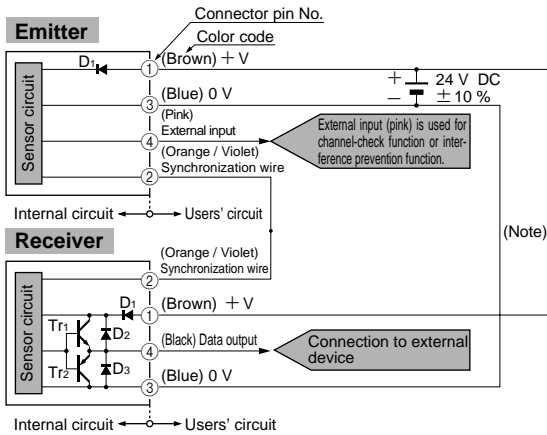

- Notes: 1) To supply power to the emitter and the receiver from separate power supplies, be sure to connect both 0 V (blue) wires in common and adjust both the power supplies to the same voltage.
 2) Unused wires must be insulated to ensure that they do not come into contact with wires already in use.

Symbols ... D1: Reverse supply polarity protection diode
 D2, D3: Surge absorption zener diode
 Tr1: NPN output transistor
 Tr2: PNP output transistor

Wiring diagram

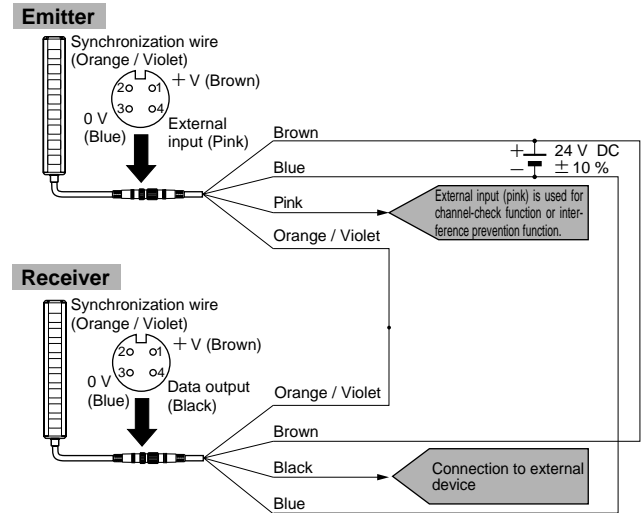

- Notes: 1) To supply power to the emitter and the receiver from separate power supplies, be sure to connect both 0 V (blue) wires in common and adjust both the power supplies to the same voltage.
 2) Unused wires must be insulated to ensure that they do not come into contact with wires already in use.

SF1-F64CB Control board

I/O circuit and wiring diagrams

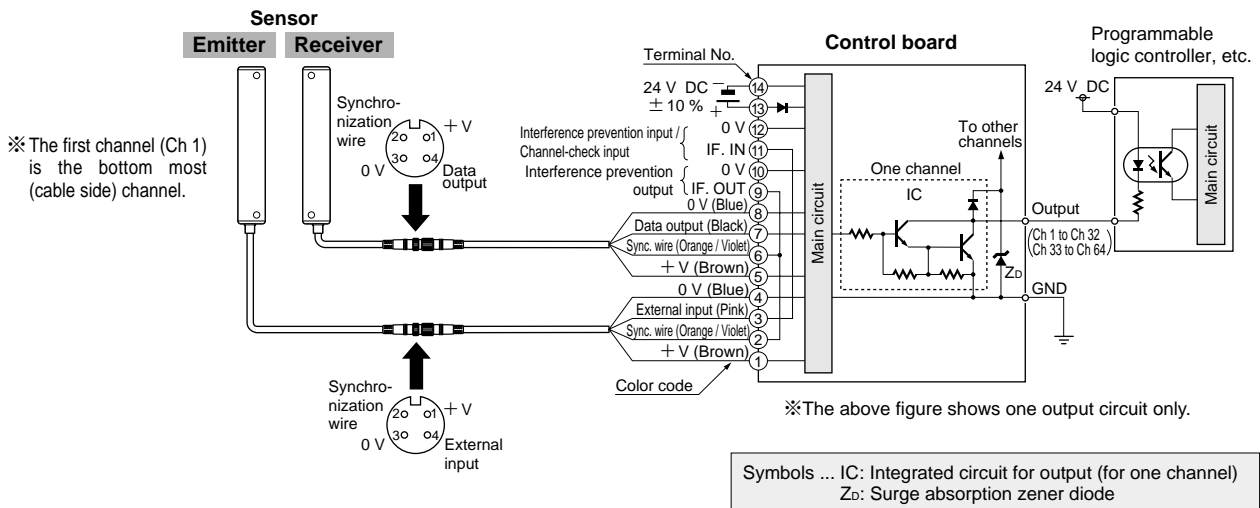

SENSING CHARACTERISTICS (TYPICAL)

Parallel deviation (All models)

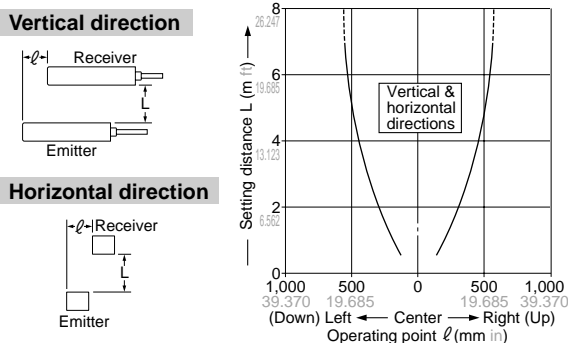

Angular deviation (All models)

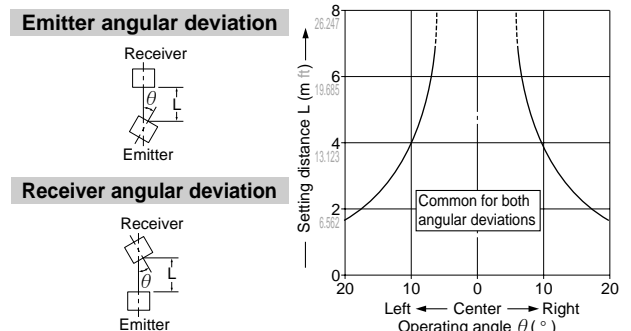

SF1-F

PRECAUTIONS FOR PROPER USE

Refer to p.1135~ for general precautions.



- Never use this product as a sensing device for personnel protection.
- For sensing devices to be used as safety devices for press machines or for personnel protection, use products which meet standards, such as OSHA, ANSI or IEC etc., for personnel protection applicable in each region or country.
- If this product is used as a sensing device for personnel protection, death or serious body injury could result.
- For a product which meets safety standards, use the following products.
Type4: **SF4-AH** series (p.420~) **SF2-EH** series (p.486~)
Type2: **SF2-A** series (p.446~) **SF2-N** series (p.464~)

Mounting

- Install the sensors where they cannot be affected by a beam reflected from a machinery frame or a workpiece. If the reflected beam is received, beam interruption is not achieved.
- Do not use the sensor without the front cover or the enclosure. IP protection cannot be maintained and a contact failure may occur between modular units.
- When mounting the sensor, the tightening torque should not exceed the value given below.

	Tightening torque
Sensor	2 N·m
Control board	0.5 N·m (M3 screw)

Wiring

- Make sure that all the wiring and connections are correct before supplying power. If power is supplied in miswired condition, the internal circuit may get damaged.
- Use a power supply that can reach the rated voltage in 500 ms or less.
- The data outputs are not incorporated with a short-circuit protection circuit. Do not connect them directly to a power supply or a capacitive load.
- Connect the emitter and the receiver with or without the control board as follows.

Use without control board

<One set of sensor>

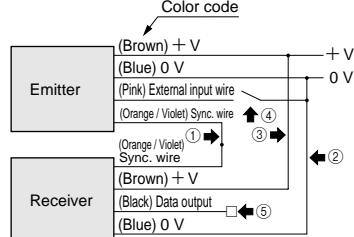

- 1 Connect both the synchronization wires.
- 2 Connect both the 0 V wires in common.
- 3 Although both the + V wires need not be connected in common, they must be at the same voltage.
- 4 To use the channel-check function connect a switch between the external input wire and 0 V. If this function is not used, insulate the external input wire.
- 5 Connect the data output wire to an external device, such as, a microcomputer board, etc.

<Two sets of sensors (Using interference prevention function)>

To install two sets of sensors as shown in the figure on the right, connect as follows.

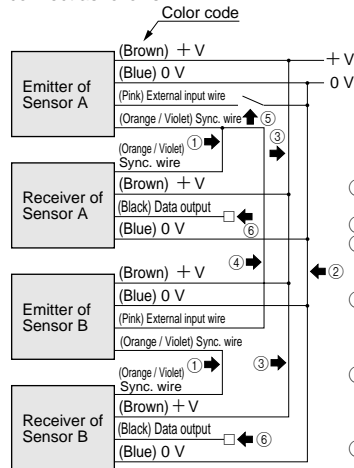

- 1 Connect together the synchronization wires of both the sensors.
- 2 Connect both the 0 V wires in common.
- 3 Although both the + V wires need not be connected in common, they must be at the same voltage.
- 4 Connect the external input wire of Sensor B to the synchronization wire of Sensor A to prevent interference between Sensor A and Sensor B.
- 5 To use the channel-check function, connect a switch between the external input wire of Sensor A and 0 V. If this function is not used, insulate the external input wire.
- 6 Connect the data output wire to an external device, such as, a microcomputer board, etc.

Use with control board

<One set of sensor>

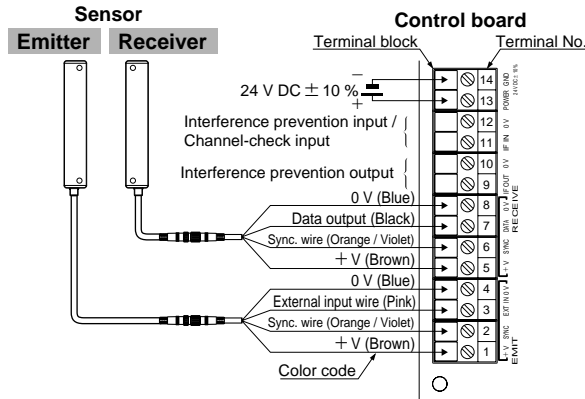

<Two sets of sensors (Using interference prevention function)>

To install two sets of sensors as shown in the figure on the right, connect as follows.

- 1 Connect IF. OUT (terminal No.9) of Control Board A to IF. IN (terminal No.11) of Control Board B.
- 2 Connect 0 V (terminal No.10) of Control Board A to 0 V (terminal No.12) of Control Board B.

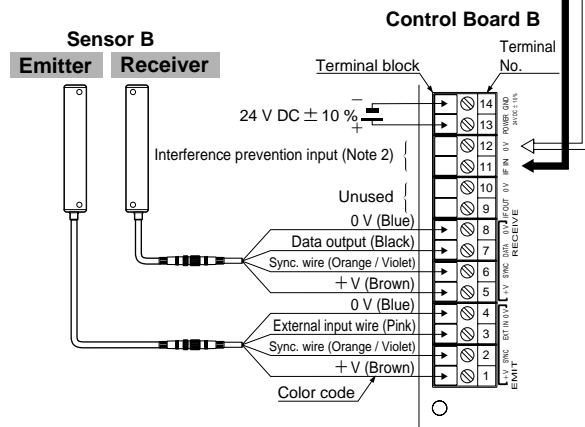
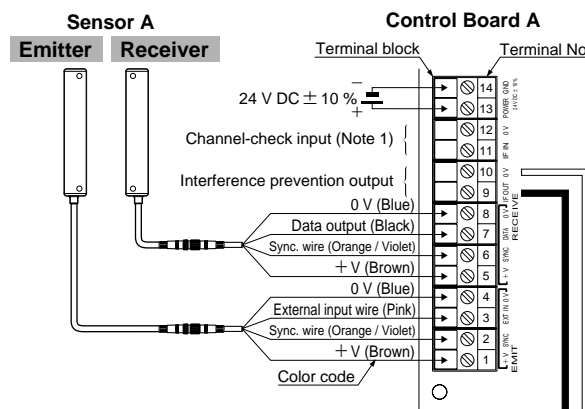
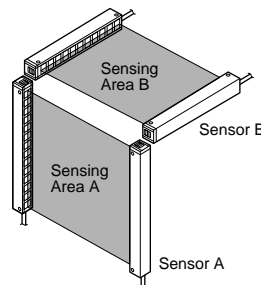

- Notes: 1) Terminal No.11 and No.12 of Control Board A are used exclusively for the channel-check input.
2) Terminal No.11 and No.12 of Control Board B are used exclusively for the interference prevention input.
Terminal No.9 and No.10 of Control Board B cannot be used.

PRECAUTIONS FOR PROPER USE

Refer to p.1135~ for general precautions.

Functional description

Sensor

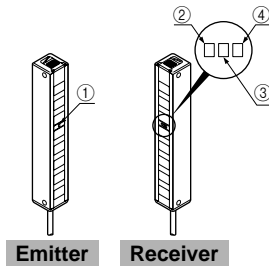

Control board

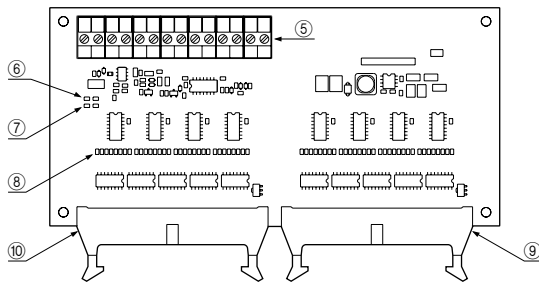

	Description	Function
Sensor	① Emitting indicator (Green LED)	Lights up under normal emission, blinks under emitting circuit failure.
	② Power indicator (Green LED)	Lights up when the sensor works normally.
	③ Error indicator (Yellow LED)	Blink alternately when the emitting circuit fails or the synchronization wire breaks.
	④ Error indicator (Red LED)	The three color indicators blink in rotation when the receiving circuit fails.
Control board	⑤ Terminal block	Emitter, receiver, power supply, and interference prevention wires are connected.
	⑥ Power indicator (Red LED)	Lights up when the power is ON.
	⑦ Sensor operation indicator (Green LED)	Lights up when the sensor works normally.
	⑧ Output indicators (Red LED) × 64	Each lights up when corresponding individual beam output is ON.
	⑨ Individual beam output Connector 1	Output connector for Ch 1 to Ch 32
	⑩ Individual beam output Connector 2	Output connector for Ch 33 to Ch 64

Connector pin position on the control board

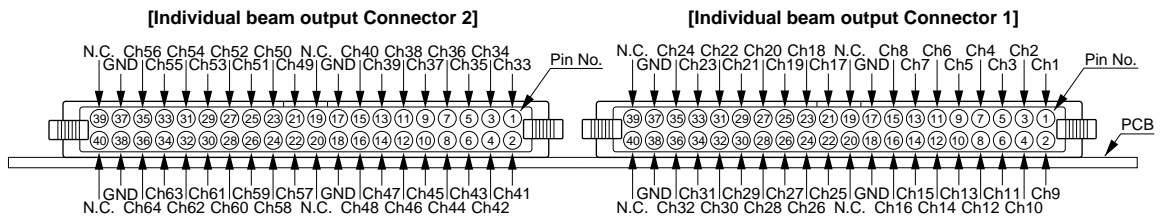

Channel-check function

- Emission of all the beam channels is halted sequentially one after the other, beginning from Ch 1, when the external input (pink) of the emitter is held Low or the channel-check input terminals No.11 and No.12 are short-circuited on the SF1-F64CB control board.

At a time, emission is stopped only for one channel while the other channels continue emission. As a result, the corresponding channels on the receiver enter the dark state sequentially. This function can be used to check if all the beam channels are operable, or not, on start-up.

<Channel-check input>

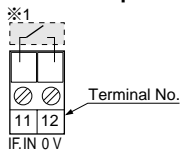

※1

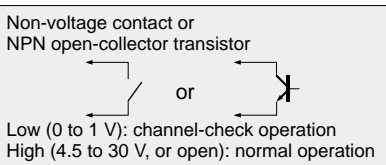

Note: When two sets are used with the interference prevention function without a control board, connect the external input wire that is not connected to the synchronization wire to 0 V.

- While the input condition is maintained, the operation continues to be repeated.
- When two sets are used with the interference prevention function, the emission of the beam channels of both Sensor A and Sensor B is halted sequentially, beginning from Ch 1.

Others

- Do not use during the initial transient time (2 sec.) after the power supply is switched on.
- Take care that the sensor is not directly exposed to fluorescent light from a rapid-starter lamp or a high frequency lighting device, as it may affect the sensing performance.
- The components on the control board may be damaged or degraded by electrostatic charge. Remove electrostatic charge from your body by earthing before handling the control board.
- The control board has no protection enclosure. The control board must be enclosed in a protective metal box, etc. If the control board gets wet or covered with dust, or if its components touch a conductor, it may get damaged.

Individual Beam Outputs

SF1-F

Slim Body

NA2-N

Picking

NA1-PK3

NA1-PK5/5

SF1-F

PRECAUTIONS FOR PROPER USE

Refer to p.1135~ for general precautions.

Data output (in case of using sensor only)

- The output of each beam is serially output in synchronization with the emitter synchronization signal.
- The output of the channel for which the beam is interrupted becomes 'Low'.

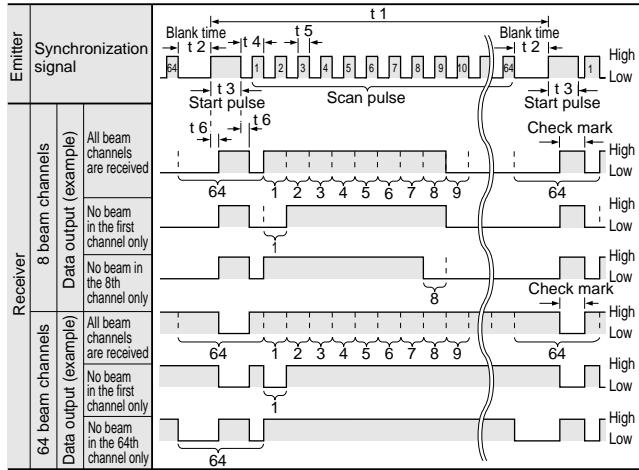
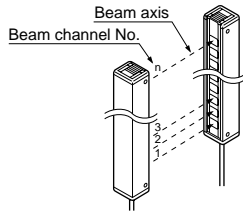

t1	t2	t3	t4	t5	t6
5 ms approx.	280 μs approx.	210 μs approx.	70 μs approx.	35 μs approx.	30 μs approx.

Start pulse

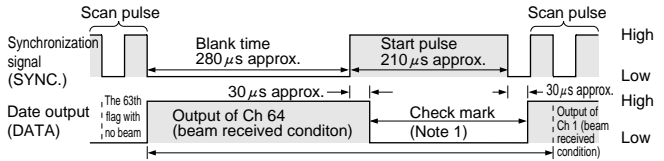

Scan pulse

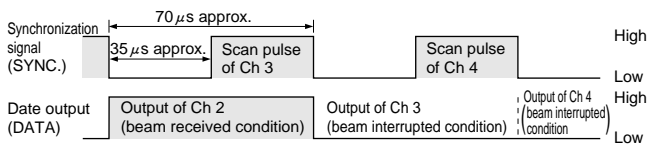

- Notes: 1) In the check mark section, the data output reverses unconditionally during approximately the start pulse time.
 2) The voltage levels for both SYNC. and DATA output are High: (Supply voltage - 1.1 V) or more, Low: 1.1 V or less

DIMENSIONS (Unit: mm in)

The CAD data in the dimensions can be downloaded from the SUNX website: <http://www.sunx.co.jp/>
 Refer to p.1112 for dimensions of the sensor mounting bracket **MS-SF1-P**.

SF1-F □ Sensor

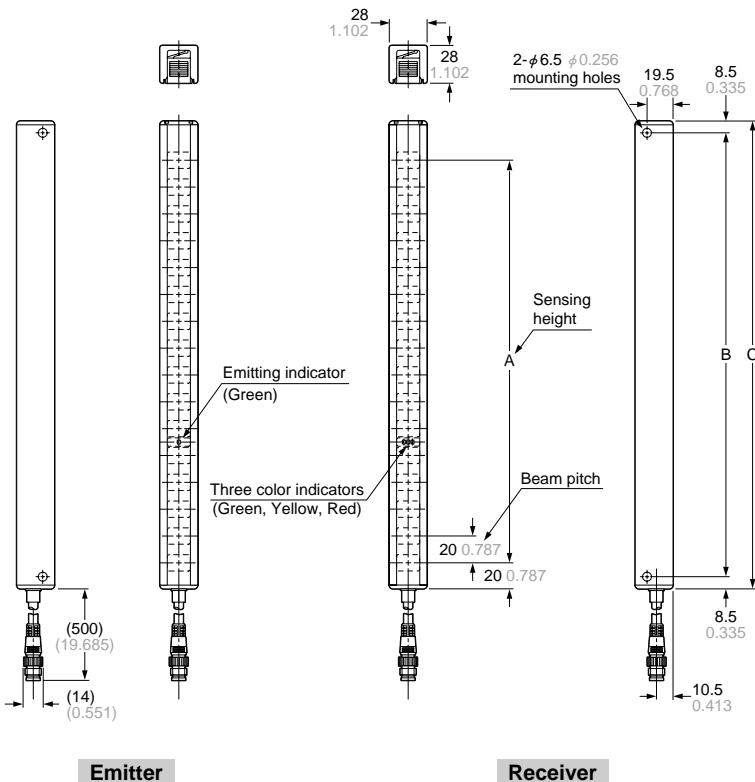

Model No.	A	B	C
SF1-F8	140 5.512	172 6.772	189 7.441
SF1-F16	300 11.811	332 13.071	349 13.740
SF1-F24	460 18.110	492 19.370	509 20.039
SF1-F32	620 24.409	652 25.669	669 26.339
SF1-F40	780 30.709	812 31.968	829 32.638
SF1-F48	940 37.008	972 38.268	989 38.937
SF1-F56	1,100 43.307	1,132 44.567	1,149 45.236
SF1-F64	1,260 49.606	1,292 50.866	1,309 51.535

DIMENSIONS (Unit: mm in)

The CAD data in the dimensions can be downloaded from the SUNX website: <http://www.sunx.co.jp/>
Refer to [p.1112](#) for dimensions of the sensor mounting bracket **MS-SF1-P**.

MS-SF1-1 Sensor mounting bracket (Accessory for sensor)

Assembly dimensions

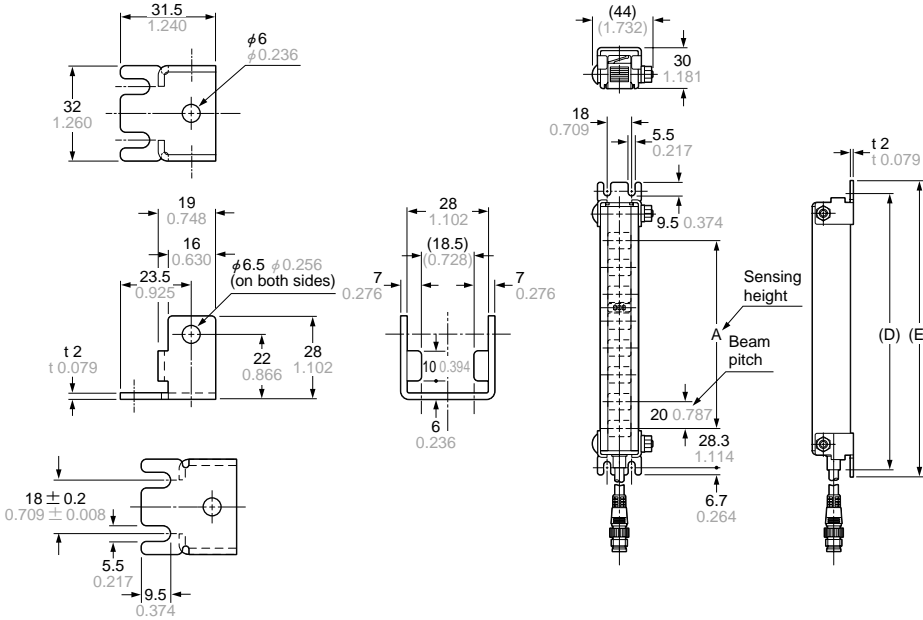

Material: Cold rolled carbon steel (SPCC)
(Uni-chrome plated)

Four bracket set
(4 psc. each of M6 (length 40 mm 1.575 in) truss head screws, nuts and spring washers are attached.)

Model No.	A	B	C
SF1-F8	140 5.512	205 8.071	219 8.622
SF1-F16	300 11.811	365 14.370	379 14.921
SF1-F24	460 18.110	525 20.669	539 21.220
SF1-F32	620 24.409	685 26.968	699 27.520
SF1-F40	780 30.709	845 33.268	859 33.819
SF1-F48	940 37.008	1,005 39.567	1,019 40.118
SF1-F56	1,100 43.307	1,165 45.866	1,179 46.417
SF1-F64	1,260 49.606	1,325 52.165	1,339 52.716

Individual Beam Outputs

SF1-F

Slim Body

NA2-N

NA1-11

Picking

NA1-PK5/5

NA1-PK3

SF1-F64CB Control board

