

TH SERIES

Hot Melt Glue Detector



Quick, reliable and non-contact detection of hot melt glue



Miniature sensor head Spot type

The sensor head can be mounted in a congested and tight place as it has a miniature size of W18 × H33 × D23 mm W0.709 × H1.299 × D0.906 in. Further, since a red alignment marker has been provided, setting can be done while confirming the detection point projected on the work-piece.



Incorporated with red marker

Sensitive and reliable detection

The spot type reliably detects a hot melt drop of 3 mm 0.118 in diameter at 85 °C 185 °F, or more, and the long sensing range type reliably detects a hot melt drop of 6 mm 0.236 in diameter (equivalent to 3 × 10 mm 0.118 × 0.394 in) at 100 °C 212 °F or more.

Long sensing range 300mm 11.811 in Long sensing range type

A long sensing range of 300 mm 11.811 in max. is possible. Hot melt glue can be reliably detected not only on small pharmaceutical or confectionary boxes, but also on large cardboard boxes.

Suitable for high speed production line

As the response time is 1 ms or less, the TH series reliably detects hot melt adhesives even where product boxes flow extremely fast.

(However, for the long sensing range type, this is valid for a sensing distance of 200 mm 7.874 in or less.)

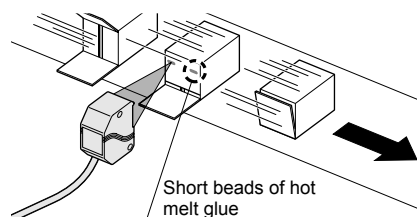

Short beads of hot melt glue

Wide sensing area Long sensing range type

Since the view field is $\phi 30$ mm $\phi 1.181$ in at a sensing distance of 300 mm 11.811 in, the hot melt glue can be detected even if its position of application varies slightly.

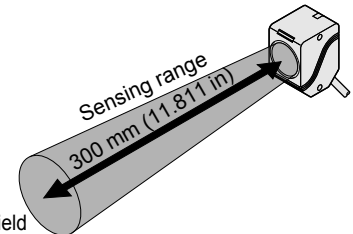

View field $\phi 30$ mm $\phi 1.181$ in approx.

Sensor head with operation indicator Long sensing range type

Since the operation indicator lights up when hot melt glue is detected, position alignment of the sensor head is easy.

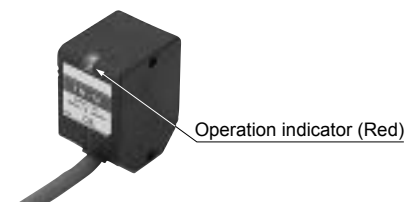

Operation indicator (Red)

Easy start-up by teaching

The optimum sensitivity can be easily set by the teaching method. Moreover, since the teaching is done with the boxes moving, it is not required to stop the production line for teaching.

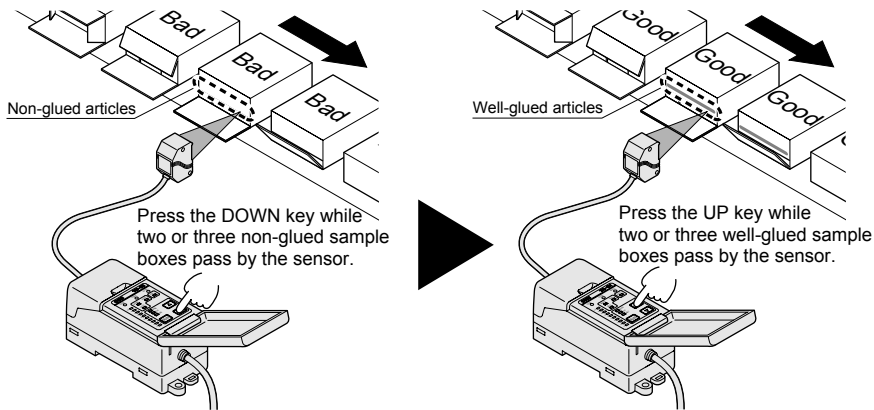

Eight-channel registration

Since sensitivity settings for eight channels can be stored, product changeover is smooth. The required channel can be selected either by the front panel or by external channel select inputs.

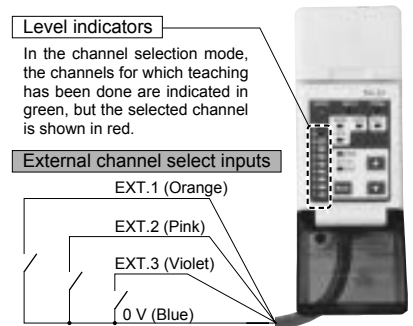

Three functions for inspecting hot melt glue application

Sensitivity level set-up To inspect quantity of applied hot melt glue

The sensitivity level (operating threshold level) can be adjusted over a scale of ten steps after the teaching. It enables detection of hot melt glue of a certain amount or more, but not inadequate glue.

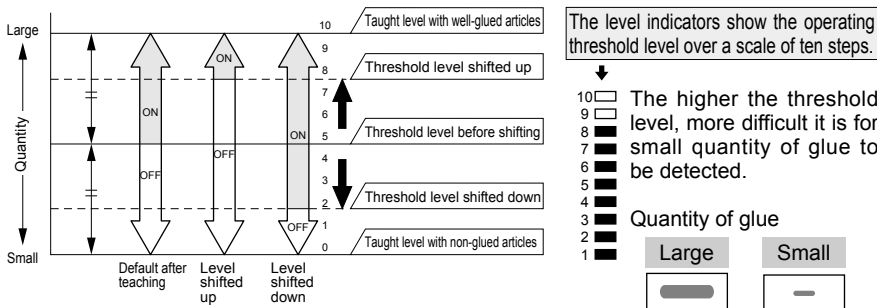

Presence evaluation To inspect presence of hot melt glue on every box

The synchronization signal corresponding to box passage is input into the controller and if the sensor detects even a small amount of glue while the box is passing, the result is OK.

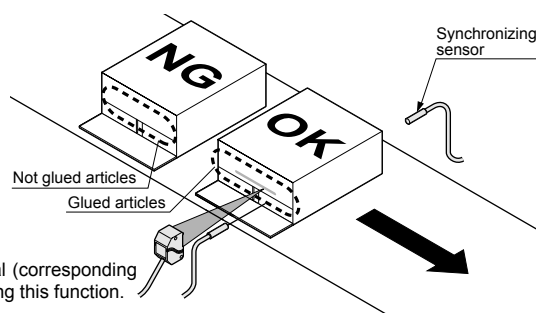

Note: An external synchronization signal (corresponding to box passage) is needed for using this function.

Length evaluation To inspect the length of hot melt bead on every box

The sensor evaluates the length of the hot melt bead as OK or NG. Since evaluation is done with the synchronization signal corresponding to the box passage input into the controller, the sensor adapts to any change in the line speed.

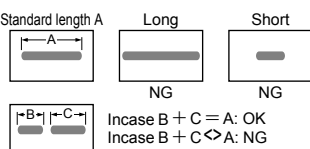
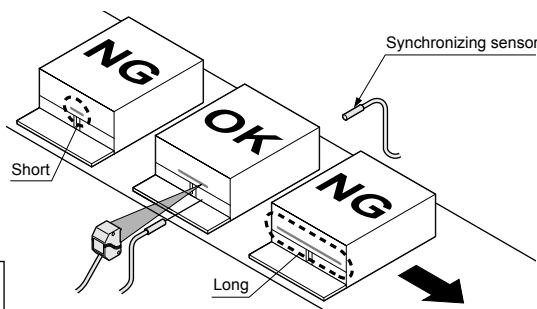

Note: An external synchronization signal (corresponding to box passage) is needed for using this function.

OFF-delay timer

The OFF-delay timer extends the output signal for an approx. 40 ms fixed time period. This is useful for detecting very short hot melt beads on a quick production line or for sending the signal to a device having a slow response time.

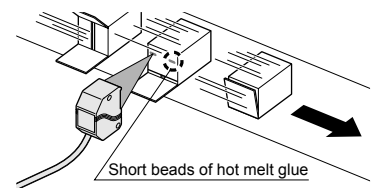

Time chart

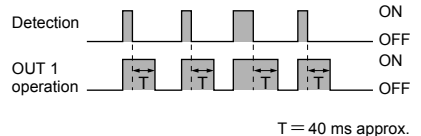

APPLICATIONS

High speed packing line

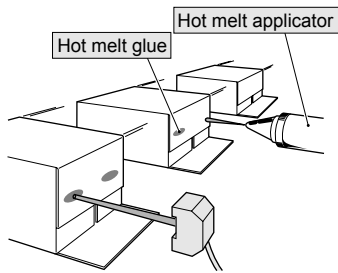

Hot melt length evaluation

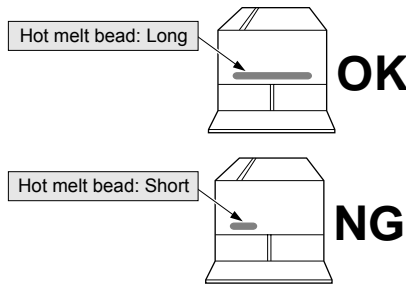

Bookbinding line

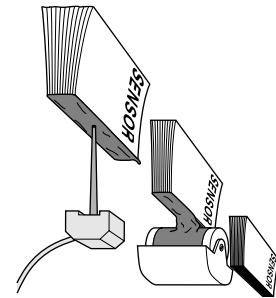

Magnetic disk assembly line

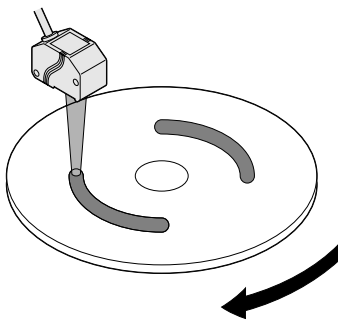

Straw attachment line

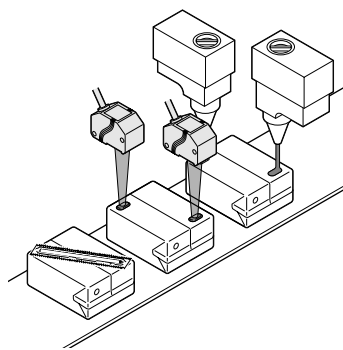

GD

Metal-sheet
Double-feed Detection

TH

Hot Melt Glue Detection

LA-T

Wire Flaw Detection

EZ-10

Water Detection

ORDER GUIDE

Type	Appearance		Sensing range	Set model No.	Output
	Sensor head	Controller			
Spot			 40 ± 10 mm 1.575 ± 0.394 in	TH-11CS	NPN open-collector transistor
Long sensing range			 10 to 300 mm 0.394 to 11.811 in (Note)	TH-12CS	NPN open-collector transistor
				TH-12CPS	PNP open-collector transistor

Note: Teaching is possible for this sensing range.

However, the sensing range varies with the size of the sensing object and its temperature, ambient temperature, etc.

A sensor head and its respective controller comprise a set. Make sure to use the sensor head and the controller specified in the set model No. together as a set. [Please refer to 'SPECIFICATIONS' on p.652, p.653 for more details.]

ORDER GUIDE

Accessories

- **MS-TH-1**
(Sensor head mounting bracket for spot type)

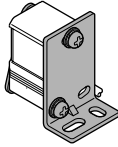

Two M3 (length 25 mm 0.984 in) screws with washers are attached.

- **TH-B1**
(Heat shield for spot type)

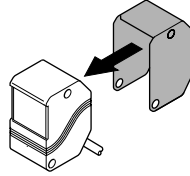

- **MS-TH-2**
(Sensor head mounting bracket for long sensing range type)

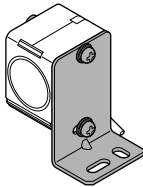

Two M3 (length 30 mm 1.181 in) screws with washers are attached.

- **TH-B2**
(Heat shield for long sensing range type)

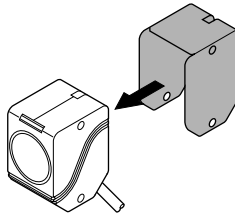

- **OS-TH12**
(Slit mask for long sensing range type)

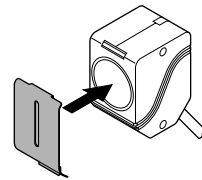

Metal-to-Metal
Double-feed Detection
GD

Hot Melt/Glue Detection
TH

Wire Flaw Detection
LA-T

Water Detection
EZ-10

SPECIFICATIONS

TH-11CS

Spot type

Sensor head

Model No.		TH-11
Item		
Applicable controller		TH-C1
Sensing range		40 ± 10 mm 1.575 ± 0.394 in
Sensing object		φ3 mm φ0.118 in or more hot melt glue (emissivity 0.9) at +85 °C +185 °F or more, under ambient temperature of +25 °C +77 °F (Note)
Environmental resistance	Ambient temperature	0 to +50 °C +32 to +122 °F (No dew condensation), Storage: -10 to +60 °C +14 to +140 °F
	Ambient humidity	35 to 85 % RH, Storage: 35 to 85 % RH
	Ambient illuminance	Sunlight: 11,000 lx at the light-receiving face, Incandescent light: 3,500 lx at the light-receiving face
	Vibration resistance	10 to 55 Hz frequency, 1.5 mm 0.059 in amplitude in X, Y and Z directions for two hours each
	Shock resistance	500 m/s ² acceleration (50 G approx.) in X, Y and Z directions for three times each
Visible targeting		Red LED
Material		Enclosure: Polycarbonate, Front cover: Sapphire glass
Cable		0.2 mm ² 3-core shielded cable, 2 m 6.562 ft long
Weight		77 g approx.
Accessories		MS-TH-1 (Sensor head mounting bracket): 1 set, TH-B1 (Heat shield): 1 pc.

Note: A hot melt drop at +60 °C +140 °F or higher can be detected if it is φ5 mm φ0.197 in or more.

Controller

Model No.		TH-C1
Item		
Applicable sensor head		TH-11
Supply voltage		12 to 24 V DC ± 10 % Ripple P-P 10 % or less
Current consumption		100 mA or less
Output (OUT 1, OUT 2)		NPN open-collector transistor <ul style="list-style-type: none"> • Maximum sink current: 100mA • Applied voltage: 30 V DC or less (between output and 0 V) • Residual voltage: 1 V or less (at 100 mA sink current) 0.4 V or less (at 16 mA sink current)
	Output operation	OUT 1: ON when hot melt adhesive is detected (Max. 1 sec. approx.), OUT 2: ON when the evaluated result is NG (Max. 1 sec. approx.)
	Short-circuit protection	Incorporated
Response time (operation freq.)		1 ms or less (1 to 200 Hz)
Warm-up time		40 sec. approx.
Sensitivity setting		Teaching method (Push-button operation)
Level storage function		Sensitivity levels of eight channels can be stored.
External channel select function		Incorporated
Timer function		Incorporated with approx. 40 ms fixed OFF-delay timer, switchable either effective or ineffective
Environmental resistance	Ambient temperature	0 to +50 °C +32 to +122 °F (No dew condensation), Storage: -10 to +60 °C +14 to +140 °F
	Ambient humidity	35 to 85 % RH, Storage: 35 to 85 % RH
	Noise immunity	Power line: 240 Vp, 10 ms cycle, and 0.5 μs pulse width (with noise simulator)
	Voltage withstandability	1,000 V AC for one min. between all supply terminals connected together and enclosure
	Insulation resistance	20 MΩ, or more, with 250 V DC megger between all supply terminals connected together and enclosure
	Shock resistance	500 m/s ² acceleration (50 G approx.) in X, Y and Z directions for three times each
Material		Enclosure: Heat-resistant ABS, Terminal cover: Heat-resistant ABS, Front cover: Polycarbonate
Cable		0.3 mm ² 8-core cabtyre cable, 2 m 6.562 ft long
Cable extension		Extension up to total 100 m 328.084 ft is possible with 0.3 mm ² , or more, cable.
Weight		200 g approx.

Note: Refer to 'Functional description' on p.658 for controller indicator functions.

SPECIFICATIONS

**TH-12CS
TH-12CPS**

Long sensing range type

Sensor head

Model No.		TH-12
Item		
Applicable controller		TH-C2, TH-C2P
Sensing range		10 to 300 mm 0.394 to 11.811 in (Note1, 2)
Sensing object		#6 mm #0.236 in (equivalent to 3 X 10 mm 0.118 X 0.394 in) or more hot melt glue (emissivity 0.9) at +100 °C +212 °F or more, under ambient temperature of +25 °C +77 °F (Note 2)
Environmental resistance	Pollution degree	3 (Industrial environment)
	Ambient temperature	0 to +50 °C +32 to +122 °F (No dew condensation), Storage: -10 to +60 °C +14 to +140 °F
	Ambient humidity	35 to 85 % RH, Storage: 35 to 85 % RH
	Ambient illuminance	Sunlight: 11,000 lx at the light-receiving face, Incandescent light: 3,500 lx at the light-receiving face
	Vibration resistance	10 to 55 Hz frequency, 1.5 mm 0.059 in amplitude in X, Y and Z directions for two hours each
	Shock resistance	500 m/s ² acceleration (50 G approx.) in X, Y and Z directions for three times each
OUT 1 operation indicator		Red LED [lights up when hot melt is detected (Max. 1 sec. approx.)]
Material		Enclosure: Polycarbonate, Indicator: Polycarbonate, Lens: Silicone
Cable		0.2 mm ² 5-core shielded cable, 2 m 6.562 ft long
Weight		120 g approx.
Accessories		MS-TH-2 (Sensor head mounting bracket): 1 set, TH-B2 (Heat shield): 1 pc., OS-TH12 (Slit mask): 1 pc.

Notes: 1) Teaching is possible for this detection range. However, the detection range varies with the size of the sensing object and its temperature, ambient temperature, etc.
2) Refer to 'Reference table for sensing distance' on p.658 for the relation between the sensing distance and the hot melt condition.

Controller

Type		NPN output (for TH-12CS)	PNP output (for TH-12CPS)
Item	Model No.	TH-C2	TH-C2P
Applicable sensor head		TH-12	
Supply voltage		12 to 24 V DC ± 10 % Ripple P-P 10 % or less	
Current consumption		100 mA or less	
Output (OUT 1, OUT 2)		NPN open-collector transistor • Maximum sink current: 100 mA • Applied voltage: 30 V DC or less (between output and 0 V) • Residual voltage: 1 V or less (at 100 mA sink current) 0.4 V or less (at 16 mA sink current)	PNP open-collector transistor • Maximum source current: 100 mA • Applied voltage: 30 V DC or less (between output and +V) • Residual voltage: 2 V or less (at 100 mA source current)
	Utilization category	DC-12 or DC-13	
	Output operation	OUT 1: ON when hot melt adhesive is detected (Max. 1 sec. approx.), OUT 2: OFF when the evaluated result is NG (Max. 1 sec. approx.)	
	Short-circuit protection	Incorporated	
Response time (operation freq.)		Sensing distance 200 mm 7.874 in or less: 1 ms or less (1 to 200 Hz), Sensing distance 300 mm 11.811 in or less: 1.5 ms or less (1 to 100 Hz)	
Warm-up time		40 sec. approx.	
Sensitivity setting		Teaching method (Push-button operation)	
Level storage function		Sensitivity levels of eight channels can be stored.	
External channel select function		Incorporated	
Timer function		Incorporated with approx. 40 ms fixed OFF-delay timer, switchable either effective or ineffective	
Environmental resistance	Pollution degree	3 (Industrial environment)	
	Ambient temperature	0 to +50 °C +32 to +122 °F (No dew condensation), Storage: -10 to +60 °C +14 to +140 °F	
	Ambient humidity	35 to 85 % RH, Storage: 35 to 85 % RH	
	EMC	EN 50081-2, EN 50082-2, EN 60947-5-2	
	Voltage withstandability	1,000 V AC for one min. between all supply terminals connected together and enclosure	
	Insulation resistance	20 MΩ, or more, with 250 V DC megger between all supply terminals connected together and enclosure	
	Vibration resistance	10 to 55 Hz frequency, 1.5 mm 0.059 in amplitude in X, Y and Z directions for two hours each	
	Shock resistance	500 m/s ² acceleration (50 G approx.) in X, Y and Z directions for three times each	
Material		Enclosure: Heat-resistant ABS, Terminal cover: Heat-resistant ABS, Front cover: Polycarbonate	
Cable		0.3 mm ² 8-core cabtyre cable, 2 m 6.562 ft long	0.3 mm ² 8-core cabtyre cable, 1 m 3.281 ft long
Cable extension		Extension up to total 100 m 328.084 ft is possible with 0.3 mm ² , or more, cable.	
Weight		200 g approx.	140 g approx.

Note: Refer to 'Functional description' on p.658 for controller indicator functions.

I/O CIRCUIT AND WIRING DIAGRAMS

NPN output type

I/O circuit diagram

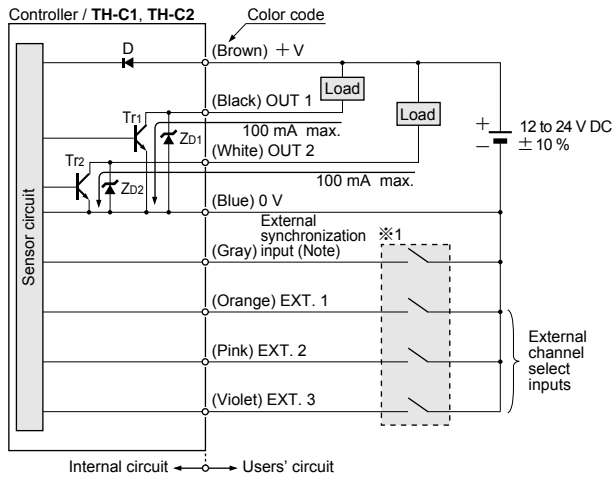

Note: The external synchronization input is active Low.

Symbols ... D: Reverse supply polarity protection diode
 Zb1, Zb2: Surge absorption zener diode
 Tr1, Tr2 : NPN output transistor

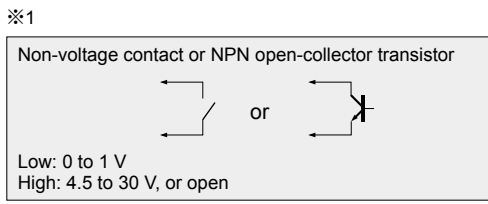

Specifying channel with external channel select inputs

Input \ Channel No.	EXT.1 (Orange)	EXT.2 (Pink)	EXT.3 (Violet)
1	L	H	H
2	H	L	H
3	L	L	H
4	H	H	L
5	L	H	L
6	H	L	L
7	L	L	L
8	H	H	H

L: Low (0 to 1 V), H: High (4.5 to 30 V, or open)

- Notes: 1) The channel can be specified from the front panel only when all external channel select inputs (EXT.1, EXT.2, and EXT.3) are High (corresponding to Channel No. 8).
 2) The external channel select inputs take precedence over the front panel channel selection (except for Channel No. 8).
 3) If channel specification is changed from front panel operation to external channel select inputs and Channel No. 8 is to be selected by the external channel call inputs, make sure to specify a channel other than No. 8 before setting all the external channel select inputs (EXT.1, EXT.2, EXT.3) to High. If this operation is not done, channel specification by front panel operation gets precedence.

Sensor head wiring diagram

TH-11CS

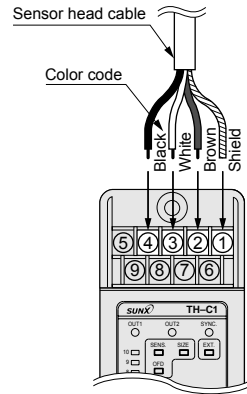

Terminal No.	Color code
①	Shield
②	Brown
③	White
④	Black
⑤ to ⑨	Not connected (Note)

Note: Do not make any connection to terminals ⑤ to ⑨. If connected, the internal circuit may get damaged.

TH-12CS

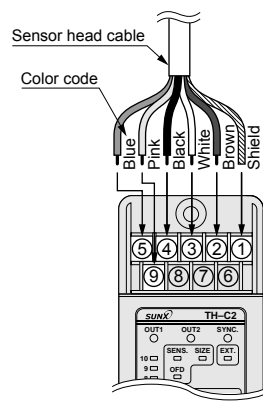

Terminal No.	Color code
①	Shield
②	Brown
③	White
④	Black
⑤	Blue
⑥ to ⑧	Not connected (Note)
⑨	Pink

Note: Do not make any connection to terminals ⑥ to ⑧. If connected, the internal circuit may get damaged.

I/O CIRCUIT AND WIRING DIAGRAMS

PNP output type

I/O circuit diagram

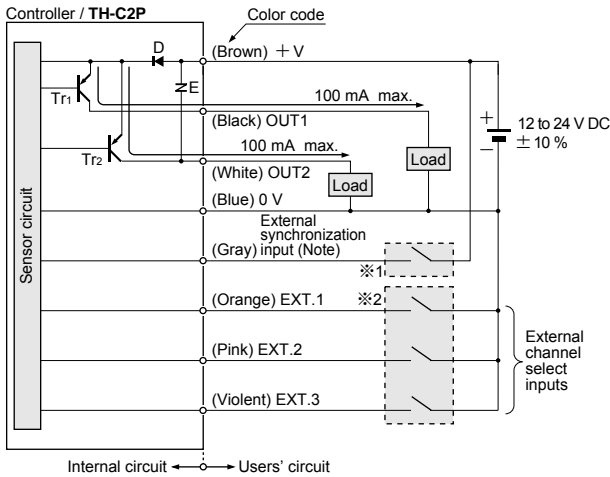

Note: The external synchronization input is active High.

Symbols ... D: Reverse supply polarity protection diode
E: Surge absorption varistor
Tr1, Tr2: PNP output transistor

※1

Non-voltage contact or PNP open-collector transistor

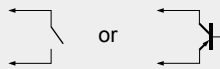

Low: 0 to 1 V
High: + V or open

※2

Non-voltage contact or NPN open-collector transistor

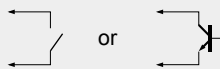

Low: 0 to 1 V
High: 4.5 to 30 V, or open

Specifying channel with external channel select inputs

Input Channel No.	EXT.1 (Orange)	EXT.2 (Pink)	EXT.3 (Violet)
1	L	H	H
2	H	L	H
3	L	L	H
4	H	H	L
5	L	H	L
6	H	L	L
7	L	L	L
8	H	H	H

L: Low (0 to 1 V), H: High (4.5 to 30 V, or open)

- Notes: 1) The channel can be specified from the front panel only when all external channel select inputs (EXT.1, EXT.2, and EXT.3) are High (corresponding to Channel No. 8).
2) The external channel select inputs take precedence over the front panel channel selection (except for Channel No. 8).
3) If channel specification is changed from front panel operation to external channel select inputs and Channel No. 8 is to be selected by the external channel call inputs, make sure to specify a channel other than No. 8 before setting all the external channel select inputs (EXT.1, EXT.2, EXT.3) to High.
If this operation is not done, channel specification by front panel operation gets precedence.

Sensor head wiring diagram

TH-12CPS

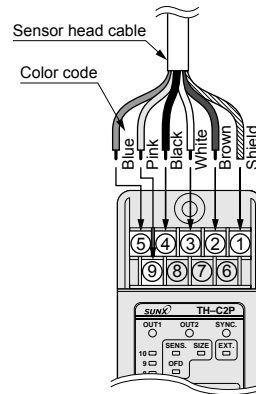

Terminal No.	Color code
①	Shield
②	Brown
③	White
④	Black
⑤	Blue
⑥ to ⑧	Not connected (Note)
⑨	Pink

Note: Do not make any connection to terminals ⑥ to ⑧. If connected, the internal circuit may get damaged.

SENSING CHARACTERISTICS (TYPICAL)

TH-11CS Spot type

Sensing fields

• Horizontal direction

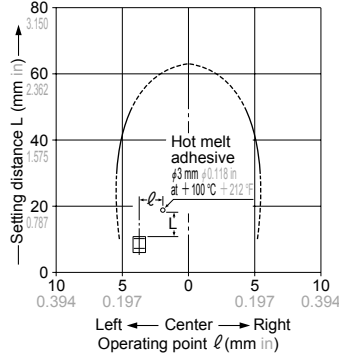

• Vertical direction

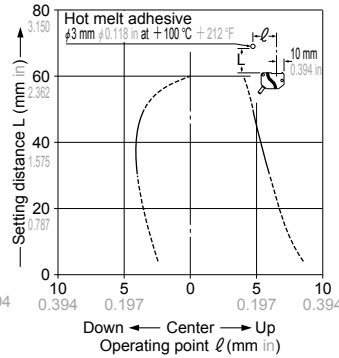

The figures on the left show the measured characteristics with $\phi 3 \text{ mm } \phi 0.118 \text{ in}$, $+100 \text{ }^\circ\text{C} +212 \text{ }^\circ\text{F}$ hot melt glue (emissivity 0.9) at setting distance 40 mm 1.575 in, ambient temperature $+25 \text{ }^\circ\text{C} +77 \text{ }^\circ\text{F}$ and with 1-level teaching.

TH-12CS TH-12CPS Long sensing range type

Sensing fields (without slit mask fitted)

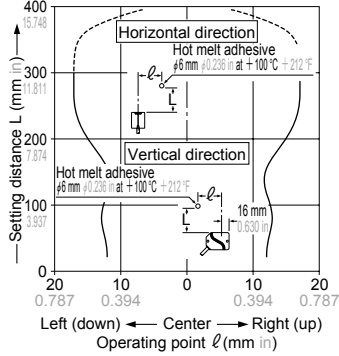

The figure on the left shows the measured characteristics with $\phi 6 \text{ mm } \phi 0.236 \text{ in}$, $+100 \text{ }^\circ\text{C} +212 \text{ }^\circ\text{F}$ hot melt glue (emissivity 0.9) at setting distance 300 mm 11.811 in, ambient temperature $+25 \text{ }^\circ\text{C} +77 \text{ }^\circ\text{F}$ and with 2-level teaching.

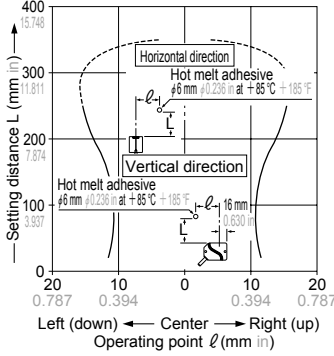

The figure on the left shows the measured characteristics with $\phi 6 \text{ mm } \phi 0.236 \text{ in}$, $+85 \text{ }^\circ\text{C} +167 \text{ }^\circ\text{F}$ hot melt glue (emissivity 0.9) at setting distance 250 mm 9.843 in, ambient temperature $+25 \text{ }^\circ\text{C} +77 \text{ }^\circ\text{F}$ and with 2-level teaching.

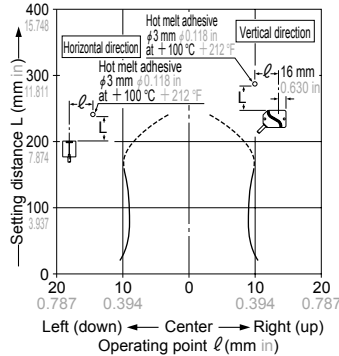

The figure on the left shows the measured characteristics with $\phi 3 \text{ mm } \phi 0.118 \text{ in}$, $+100 \text{ }^\circ\text{C} +212 \text{ }^\circ\text{F}$ hot melt glue (emissivity 0.9) at setting distance 160 mm 6.299 in, ambient temperature $+25 \text{ }^\circ\text{C} +77 \text{ }^\circ\text{F}$ and with 2-level teaching.

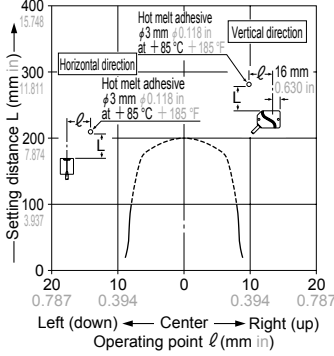

The figure on the left shows the measured characteristics with $\phi 3 \text{ mm } \phi 0.118 \text{ in}$, $+85 \text{ }^\circ\text{C} +167 \text{ }^\circ\text{F}$ hot melt glue (emissivity 0.9) at setting distance 100 mm 3.937 in, ambient temperature $+25 \text{ }^\circ\text{C} +77 \text{ }^\circ\text{F}$ and with 2-level teaching.

Sensing fields (with slit mask fitted)

• Horizontal direction

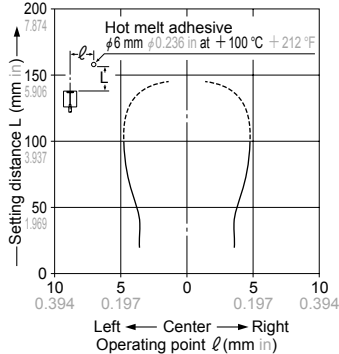

• Vertical direction

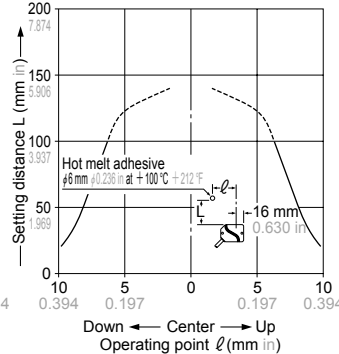

The figures on the left show the measured characteristics with the enclosed slit fitted, $\phi 6 \text{ mm } \phi 0.236 \text{ in}$, $+100 \text{ }^\circ\text{C} +212 \text{ }^\circ\text{F}$ hot melt glue (emissivity 0.9) at setting distance 100 mm 3.937 in, ambient temperature $+25 \text{ }^\circ\text{C} +77 \text{ }^\circ\text{F}$ and with 2-level teaching.

If the slit mask is fitted, the sensing distance is about 1/3 of the sensing distance without the slit mask. (Refer to the 'Reference table for sensing distance' on p.658)

PRECAUTIONS FOR PROPER USE



This product is not a safety sensor. Its use is not intended or designed to protect life and prevent body injury or property damage from dangerous parts of machinery. It is a normal object detection sensor.

Mounting

Mounting sensor head

<In case of TH-11CS>

- The tightening torque should be 0.5 N·m or less.
- Use the attached heat shield **TH-B1**, if the sensor head is installed nearby a hot melt applicator.

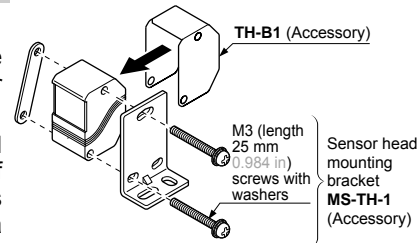

<In case of TH-12CS, TH-12CPS>

- The tightening torque should be 0.5 N·m or less.
- Use the attached heat shield **TH-B2**, if the sensor head is installed near a hot melt applicator.
- When length evaluation, etc., of a short hot melt glue is to be done, install the attached slit (**OS-TH12**). However, if the slit is used, the sensing range reduces.

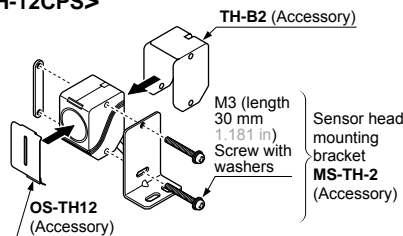

Mounting controller

<Using DIN rail>

- ① Push the DIN rail stopper in the direction of the arrow to lock it. Hook the front (non-stopper) side of the bottom slot on the 35 mm 1.378 in width DIN rail. (When pushing in the stopper, lightly press the stopper groove downwards.)
- ② Now, press down the rear side of the bottom slot on the 35 mm 1.378 in width DIN rail to fit it.
- ③ For removing, insert a 'minus' screwdriver into the hole of the DIN rail stopper and pull it out.

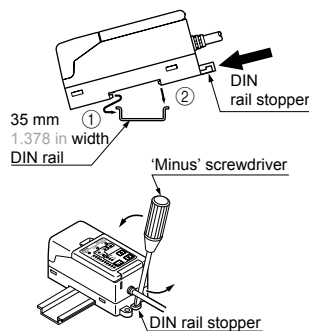

<Using screws>

- Use two M4 pan head screws. The tightening torque should be 1.2 N·m or less.

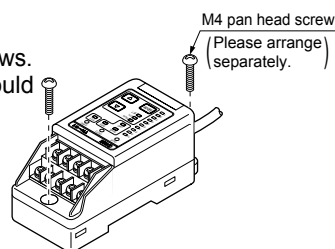

Wiring

- Make sure that the power supply is off while wiring.
- Verify that the supply voltage variation is within the rating.
- If power is supplied from a commercial switching regulator, ensure that the frame ground (F.G.) terminal is connected to an actual ground.
- In case noise generating equipment (switching regulator, inverter motor, etc.) is used in the vicinity of this product, connect the frame ground (F.G.) terminal of the equipment to an actual ground.
- Do not run the wires together with high-voltage lines or power lines or put them in the same raceway. This can cause malfunction due to induction.
- The sensor head cable cannot be extended.

Others

- Since the **TH** series employs a differential method for sensing, if the length of the box or its traveling speed is different from that at the time of teaching, proper sensing may not be possible. Make sure to teach under the actual sensing conditions.
- If the sensor is used in an environment of marked temperature changes, perform the teaching periodically for stable detection.
- Do not use the **TH** series during the warm-up time (40 sec. approx.) after the power supply is switched on. Further, do not touch any key during the warm-up time, as this may erase the sensitivity settings stored in the controller.
- In case the power supply is switched off in a mode other than the RUN mode, take care that operation commences in the channel selection mode when the power supply is switched on again.
- Avoid dust, dirt, and steam.
- Take care that the product does not come in direct contact with water, oil, grease, or organic solvents, such as, thinner, etc.
- Wipe the lens of the sensor head clean with a cloth damped with ethanol if hot melt glue, dirt, etc, sticks to it.
- Make sure to detect the hot melt glue with the sensing object moving. Stationary hot melt glue cannot be detected.
- The time duration for detecting hot melt glue should be 1 sec. or less. If this time duration exceeds 1 sec., OUT 1 automatically turns OFF. Take care that, in this case, it may take approx. 40 sec. max., after being brought to the no-detection state, for the sensor to return to the stable sensing condition.
- Do not place any heat source such as an incandescent lamp around the sensor head or the hot melt glue application area. It may cause a malfunction.
- If some thermal reflector (glossy object, etc.) exists near the hot melt glue application area, the reflected heat may cause an error. In this case, install a heat shield, etc., to make sure that the reflected heat does not reach the sensor head.
- Make sure that sunlight, or light from an incandescent lamp or fluorescent lamp does not enter the sensor head directly. In addition, also take care against reflected sunlight or reflected light from an incandescent lamp.

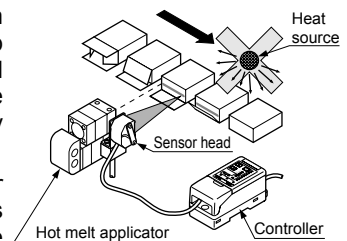

PRECAUTIONS FOR PROPER USE

Emissivity

• The emissivity varies with the sensing object. This sensor can also detect other high emissivity objects besides hot melt glue (emissivity 0.9). Further, detection of low emissivity objects is also possible depending on the temperature or surface area.

Emissivity of different objects

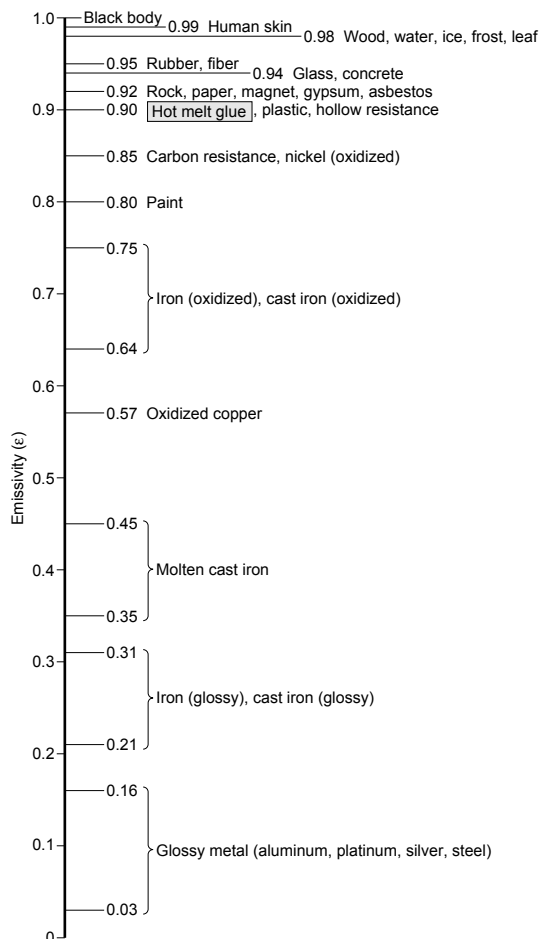

Reference table for sensing distance (TH-12CS or TH-12CPS)

• The relation between the sensing distance and the hot melt condition is given in the table below.

Temperature [°C °F]	Hot melt Size [mm in]	Sensing distance [mm in]	
		Without slit mask fitted	With slit mask fitted
+ 85 + 185	φ3 φ0.118	10 to 100 0.394 to 3.937	—
	φ5 φ0.197	10 to 210 0.394 to 8.268	—
	φ6 φ0.236	10 to 250 0.394 to 9.843	—
	3 × 10 0.118 × 0.394	10 to 250 0.394 to 9.843	—
	6 × 10 0.236 × 0.394	10 to 330 0.394 to 12.992	10 to 110 0.394 to 4.331
+ 100 + 212	φ3 φ0.118	10 to 160 0.394 to 6.299	—
	φ5 φ0.197	10 to 260 0.394 to 10.236	10 to 86 0.394 to 3.386
	φ6 φ0.236	10 to 300 0.394 to 11.811	10 to 100 0.394 to 3.937
	3 × 10 0.118 × 0.394	10 to 300 0.394 to 11.811	10 to 100 0.394 to 3.937
	6 × 10 0.236 × 0.394	10 to 400 0.394 to 15.748	10 to 133 0.394 to 5.236

Functional description

Controller (common)

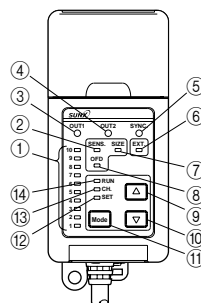

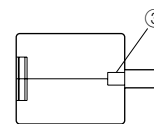

Sensor head / TH-12



Description	Function
① Level indicators (2-color LEDs)	<ul style="list-style-type: none"> In RUN mode Indicate the sensing level in real time. In CH. selection mode (CH.) Indicate the teaching state of each channel. (For details, see 'Sensitivity setting' on p.659.) In teaching mode (SET) Indicate the sensing level during teaching, in real time. After the teaching, the level indicators blink in green to indicate the allowable ambient temperature range for actual use. (For details, see 'Sensitivity setting' on p.659.) When the teaching fails, all level indicators blink in red continuously. In sensitivity level set-up mode (SENS.) Indicate the sensitivity level (operating threshold level) in ten steps. (For details, see 'Sensitivity level set-up function' on p.660.) In length evaluation mode (SIZE) Indicate the relative tolerance of the evaluated bead length in ten steps. (For details, see 'Presence / absence detection (function · length evaluation function (SIZE))' on p.660.) In OFF-delay timer set-up mode (OFD) Timer ON: the indicators numbered 1 to 4 light up. Timer OFF: all indicators go off.
② Sensitivity level set-up mode indicator (SENS.) (Green LED)	<ul style="list-style-type: none"> Lights up in the sensitivity level set-up mode (SENS.). Lights up in all three modes, RUN, CH., and SET, when teaching has been done. Blinks during the warm-up time (40 sec. approx.) immediately after the power supply is switched on.
③ OUT 1 Operation indicator (Red LED)	<ul style="list-style-type: none"> Lights up when the OUT 1 is ON. (If the detection time is small, it is possible that the indicator on the sensor head may not light up synchronously with the controller indicator or may not light up at all. (TH-12CS, TH-12CPS))
④ OUT 2 Operation indicator (Red LED)	<ul style="list-style-type: none"> Lights up when the evaluated results is NG. TH-11CS: lights up when the OUT 2 is ON. TH-12CS, TH-12CPS: lights up when the OUT 2 is OFF.
⑤ External synchronization input indicator (SYNC.) (Red LED)	<ul style="list-style-type: none"> Lights up when the external synchronization input is ON (Low). (TH-11CS, TH-12CS) Lights up when the external synchronization input is ON (High). (TH-12CPS)
⑥ External channel selection indicator (EXT.) (Green LED)	<ul style="list-style-type: none"> Lights up when either EXT.1, EXT.2, or EXT.3 is Low. Blinks during the warm-up time (40 sec. approx.) immediately after the power supply is switched on.
⑦ Length evaluation mode indicator (SIZE) (Green LED)	<ul style="list-style-type: none"> Lights up in length evaluation mode (SIZE). Lights up in RUN mode also when the length evaluation is active at the selected channel. (The synchronization signal should be input while teaching) (the TH series to effect the length evaluation.) Blinks during the warm-up time (40 sec. approx.) immediately after the power supply is switched on.
⑧ OFF-delay timer set-up mode indicator (OFD) (Green LED)	<ul style="list-style-type: none"> Lights up in OFF-delay timer set-up mode (OFD). Lights up in RUN mode also when the OFF-delay is set at the selected channel. Blinks during the warm-up time (40 sec. approx.) immediately after the power supply is switched on.
⑨ UP key	<ul style="list-style-type: none"> Increments level in each set-up mode. Prompts the TH series to learn well-glued articles during teaching in SET mode.
⑩ DOWN key	<ul style="list-style-type: none"> Decrements level in each set-up mode. Prompts the TH series to learn non-glued articles during teaching in SET mode.
⑪ Mode key	<ul style="list-style-type: none"> Selects each set-up mode.
⑫ Teaching mode indicator (SET) (Green LED)	<ul style="list-style-type: none"> Lights up in teaching mode (SET). Blinks during the warm-up time (40 sec. approx.) immediately after the power supply is switched on.
⑬ CH. selection mode indicator (CH.) (Green LED)	<ul style="list-style-type: none"> Lights up in CH. selection mode (CH.). Blinks during the warm-up time (40 sec. approx.) immediately after the power supply is switched on.
⑭ RUN mode indicator (RUN) (Green LED)	<ul style="list-style-type: none"> Lights up in RUN mode. Blinks during the warm-up time (40 sec. approx.) immediately after the power supply is switched on.

PRECAUTIONS FOR PROPER USE

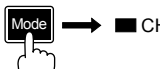
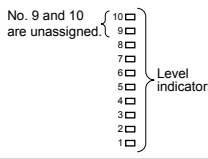
Sensitivity setting

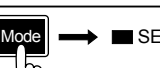
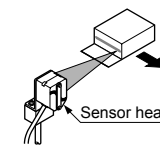
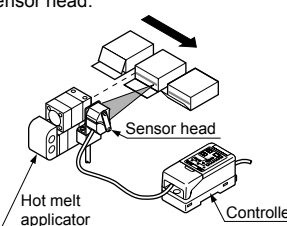
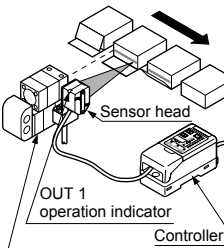
Step	Operation
Starting up	<p>① Switch on the power supply</p> <ul style="list-style-type: none"> During the warm-up time (40 sec. approx.), several indicators on the panel blink. The RUN mode indicator then lights up. Do not operate the keys during the warm-up time (40 sec. approx.).
Channel selection	<p>② Press the Mode key once to enter into the CH. selection mode (CH.).</p>  <ul style="list-style-type: none"> The level indicators indicate the teaching condition of each channel. (The TH series has eight channels) numbered from No. 1 to 8. Lights up green: Teaching done Lights off : Teaching not done Lights up red : Selected 
	<p>③ Select the channel. (Note 1)</p> <ul style="list-style-type: none"> Select the channel with UP and DOWN keys. (The channel selection is available from No. 1 to 8.) The selected channel indicator lights up red. 
Beam alignment	<p>④ Press the Mode key again to enter into the teaching mode (SET).</p> 
	<p>⑤ Align the beam axis.</p> <p>In case of TH-11CS</p> <ul style="list-style-type: none"> Fix the sensor head after aligning the red marker emitted by the sensor head with the position through which the hot melt glue passes. <p>In case of TH-12CS, TH-12CPS</p> <ul style="list-style-type: none"> Fix the sensor head after aligning its front face along the direction in which the hot melt glue passes. 
	<p>The box on which hot melt glue has been applied is made to pass the sensor head.</p> <p>In case of TH-11CS</p> <ul style="list-style-type: none"> When hot melt glue is detected, OUT 1 operation indicator of the controller lights up in red. Moreover, if you desire to perform the beam alignment accurately, carry out the alignment while confirming the detection level from the controller's level indicators.  <p>In case of TH-12CS, TH-12CPS</p> <ul style="list-style-type: none"> When hot melt glue is detected, OUT 1 operation indicators of the sensor head and the controller light up in red. ※ In case the detection time is short, it is possible that the sensor head indicator may not light up or light up at the same time as the controller indicator. Moreover, if you desire to perform the beam alignment accurately, carry out the alignment while confirming the detection level from the controller's level indicators. 

Teach in the teaching mode (SET).

- Make sure to perform the teaching when the box is moving.
- To effect either presence or length evaluation, the external signal synchronized with travelling boxes must be input during teaching. Non-glued articles must be taught earlier than well-glued articles. (Refer to p.660 for 'Presence / absence detection function -') (Length evaluation function (SIZE)).

Either, **2-level teaching** in which, both, well-glued and non-glued articles are taught, or **1-level teaching**, in which only well-glued articles are taught, is possible.

However, the **2-level teaching** is recommended, unless you have only well-glued articles, because of its much more stable detection.

2-level teaching <Teaching timing> reference

(1) 5 to 7 non-glued boxes will pass through consecutively. After 3 or 4 boxes have gone through, continuously press the DOWN key for a moment while 2 or 3 are passing through. (Note 2)



(2) 5 to 7 well-glued boxes will pass through consecutively. After 3 or 4 boxes have gone through, continuously press the UP key for a moment while 2 or 3 boxes are passing through. Doing so will confirm the sensitivity setting.



(3) If using the Presence / absence detection function or the length evaluation function, in order to input the length determination data, make sure to let 2 or 3 boxes (well-glued) go through even after releasing the UP key.

Result of teaching

The temperature and the amount of thermal radiation from hot melt glue limit the operating ambient temperature range. The level indicators indicate this after the teaching.

a) If use is possible over the ambient temperature range [0 to +50 °C (+32 to +122 °F)], all the ten level indicators blink (green) twice after the teaching.

b) If use is possible over the ambient temperature range [0 +32 to (ambient temperature during teaching +10 °C +50 °F)], all the ten level indicators blink (green) continuously after the teaching.

c) If use is possible over the ambient temperature range [0 +32 to (ambient temperature during teaching +5 °C +35.6 °F)], five level indicators blink (green) continuously after the teaching.

d) If teaching is not done properly, all the level indicators blink continuously (red). In this case, press the Mode key to change once to some other mode, then set to the teaching mode (SET) and repeat the procedure from '⑤ Align the beam axis.' (Note 3)

(4) If the Mode key is pressed to set to RUN mode, the sensitivity level is set to Level 5 and length evaluation level is set to Level 10 automatically (presence / absence detection).

※ 'SENS' (sensitivity level set-up mode indicator) of the taught channel lights up in RUN mode too.

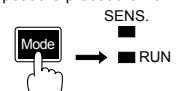

1-level teaching

- Carry out the step (2), (3) and (4). Then the teaching is completed.

- Notes:
- Channel selection is possible from the front panel only when all external channel select inputs, EXT.1, EXT.2 and EXT.3, are High.
 - When carrying out 2-level teaching, make sure to continuously press the Down key. If the Down key is not continuously pressed, 1-level teaching is carried out.
 - If the teaching is repeatedly unsuccessful, some other heat source may exist around the sensor head or near the hot melt glue application area. Check the surroundings and screen the sensor head from extraneous heat radiation.
 - The set data is not erased even when power is switched off.

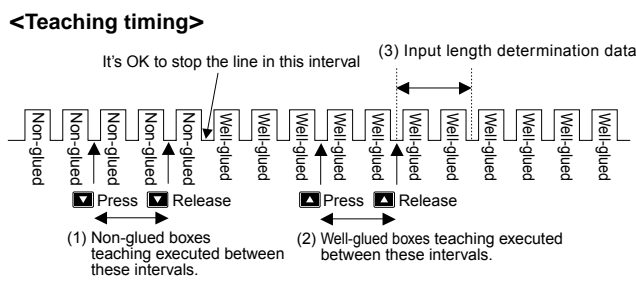

PRECAUTIONS FOR PROPER USE

Sensitivity level set-up function (SENS.)

- This function enables adjustment of the sensitivity level (operating threshold level) in ten steps after the teaching. It enables fine sensitivity adjustment to accept only adequate hot melt glue.

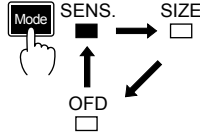
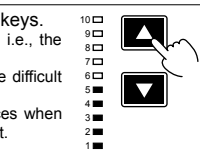
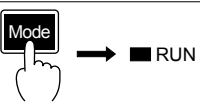
Step	Operation
①	Refer to 'Sensitivity setting' on p.659, and teach the TH series. • If the sensitivity has already been set, start from step ②. • To adjust the sensitivity stored in another channel, select the channel by referring to 'Sensitivity setting' on p.659.
②	Press the Mode key for 3 sec. or more. • After that, the Mode key enables you to select the SENS., SIZE, and OFD. modes in rotation. Select 'SENS.', the sensitivity level set-up mode. 
③	Adjust the sensitivity level with UP and DOWN keys. • After teaching, the sensitivity level is set to Level 5, i.e., the center of well-glued and non-glued levels. • As the sensitivity level is increased, it becomes more difficult to detect a hot melt glue of less quantity. ※If decreasing the sensitivity level, there are instances when the level cannot be decreased beyond a certain point. 
④	Press the Mode key for 3 sec. or more to return to the RUN mode. 

Presence / absence detection function • Length evaluation function (SIZE)

Presence / absence detection function

- This function examines the presence of even a small quantity of hot melt glue during the external synchronization signal input period and if it is detected, the result is OK. Otherwise the result is NG and OUT 2 is turned OFF (TH-11CS: ON) (1 sec. approx.).

<Time chart>

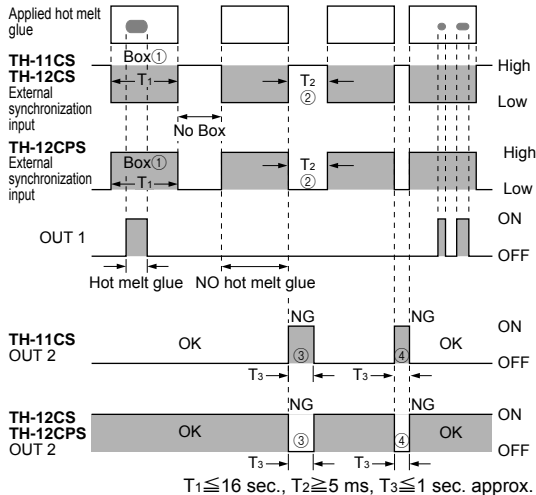

- T_1 , the external synchronization input time at Low level, should be 16 sec. or less.
- T_2 , the OFF time duration between two synchronization input pulses, should be 5 ms or more.
- OUT 2 is output when the external synchronization input rises to High level. (In case of TH-12CPS, the external synchronization input operation is reversed.)
- If the next external synchronization signal is input while OUT 2 is being output, in case of TH-11CS, OUT 2 becomes OFF and, in case of TH-12CS or TH-12CPS, OUT 2 becomes ON at that instant.

Length evaluation function

- This function examines the length of hot melt bead applied on every box. It measures if the time duration of detecting hot melt glue is longer or shorter than the criterion predetermined with well-glued articles. If the result is NG, OUT 2 is turned OFF (TH-11CS: ON) for 1 sec. approx. As the evaluation is done by feeding the synchronization signal of the moving boxes into the controller, the TH series can adapt to a change in line speed.

<Time chart>

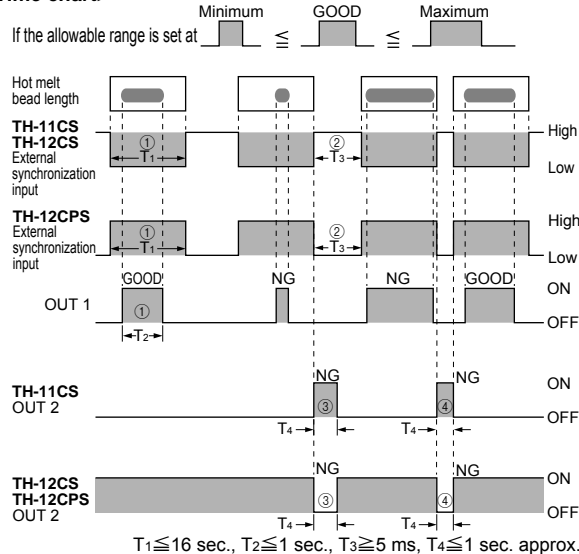

- T_1 , the time duration of the external synchronization input pulse, is 16 sec. max. Further, the upper limit of the hot melt glue detection time T_2 is 1 sec. and the time taken for stable operation of the length evaluation function is 200 ms max.
- T_3 , the time duration between two synchronization input pulses (box passage signal), should be 5 ms or more.
- OUT 2 is output when the external synchronization input rises to High level. (In case of TH-12CPS, the external synchronization input operation is reversed.)
- If the next external synchronization signal is input while OUT 2 is being output, in case of TH-11CS, OUT 2 becomes OFF and, in case of TH-12CS or TH-12CPS, OUT 2 becomes ON at that instant.

• In case the length evaluation function is used, do not change the sensitivity level from Level 5 (condition immediately after teaching).

PRECAUTIONS FOR PROPER USE

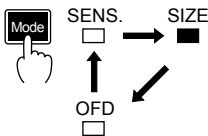
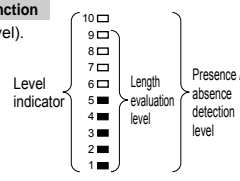
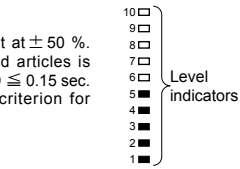
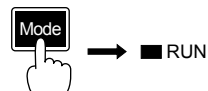
Step	Operation
①	<p>Refer to 'Sensitivity setting' on p.659 and teach the TH series.</p> <ul style="list-style-type: none"> If teaching has already been done, carry out the operations from procedure ②. If a different channel is being set, select the channel by referring to 'Sensitivity setting' on p.659. <div style="border: 1px solid black; padding: 5px; margin-top: 10px;"> <ul style="list-style-type: none"> While teaching, non-glued articles must be taught before well-glued articles. While teaching the TH series, make sure to input the external synchronization signal (box passage signal). In case OUT 2 is used, input the external synchronization signal (box passage signal) even at the time of teaching. </div>
②	<p>Press the Mode key for 3 sec. or more.</p> <p>After that, the Mode key enables you to select the SENS., SIZE, and OFD modes in rotation. Select 'SIZE', the length evaluation mode.</p> 
③	<p>Press the UP key and the DOWN key to set the length evaluation level for presence / absence detection function and length evaluation function.</p> <ul style="list-style-type: none"> Normally, it is set to presence / absence detection function. (Level 10) <div style="border: 1px solid black; padding: 5px; margin-top: 10px;"> <p>In case of using presence / absence detection function Set to Level 10 (presence / absence detection level).</p> <p>In case of using length evaluation function Set to Level 1 to 9 (length evaluation level).</p>  </div> <ul style="list-style-type: none"> The allowable range of the bead length (detection time duration) is set as a (±) percentage relative to the reference bead length of well-glued articles. The level indicators represent ± 10 % each. The allowable range for length evaluation can be adjusted from ± 10 % to ± 90 % ± 100 % results in an operation which is the same as presence / absence defecation function. <p>(e.g.)</p> <p>In the right figure, the allowable range is set at ± 50 %. If the reference bead duration of well-glued articles is 0.1 sec.; 0.05 sec. (0.1 sec. × 50 %) ≤ GOOD ≤ 0.15 sec. (0.1 sec. × 150 %) is formulated as the criterion for accepting articles.</p> 
④	<p>Press the Mode key for 3 sec. or more to return to RUN mode.</p> 

OFF-delay timer function (OFD)

- The controller is equipped with an approx. 40 ms fixed OFF-delay timer. Since it extends the output duration of OUT 1 by a fixed time interval, it is convenient to detect short hot melt beads on a quick production line or to send the signal to a device having a slow response time.

Time chart

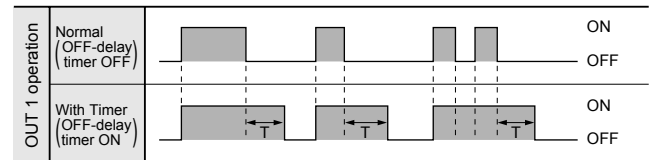

Note: The OFF-delay timer is effective only for OUT 1. T = 40 ms approx.

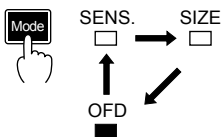
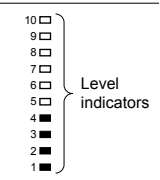
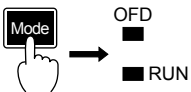
Step	Operation
①	<p>Refer to 'Sensitivity setting' on p.659 and select the channel.</p> <ul style="list-style-type: none"> If the channel is not to be changed, start from Step ②.
②	<p>Press the Mode key for 3 sec. approx. or more.</p> <p>After that, the Mode key enables you to select the SENS., SIZE, and OFD modes in rotation. Select 'OFD', the OFF-delay timer set-up mode.</p> 
③	<p>Press the UP key.</p> <ul style="list-style-type: none"> The level indicators numbered from 1 to 4 light up in green to notify that the OFF-delay timer is set. When the DOWN key is pressed, the OFF-delay timer turns OFF. (All level indicators go off.) 
④	<p>Press the Mode key for 3 sec. or more to return to RUN mode.</p> <ul style="list-style-type: none"> The 'OFD' indicator always lights up even in the RUN mode once the OFF-delay timer is set. 

DIMENSIONS (Unit: mm in) The CAD data in the dimensions can be downloaded from the SUNX website:

TH-11CS Spot type

Sensor head / TH-11

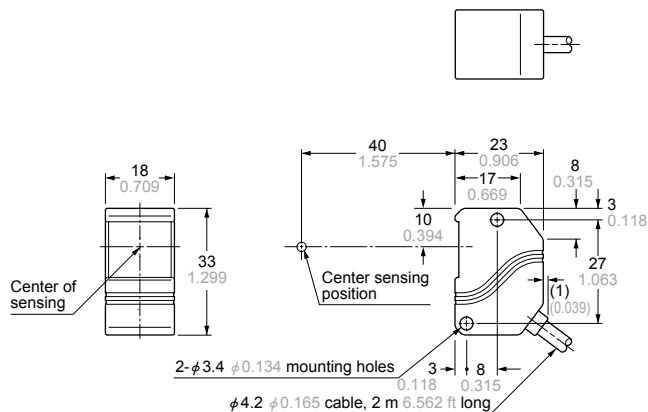

Controller / TH-C1

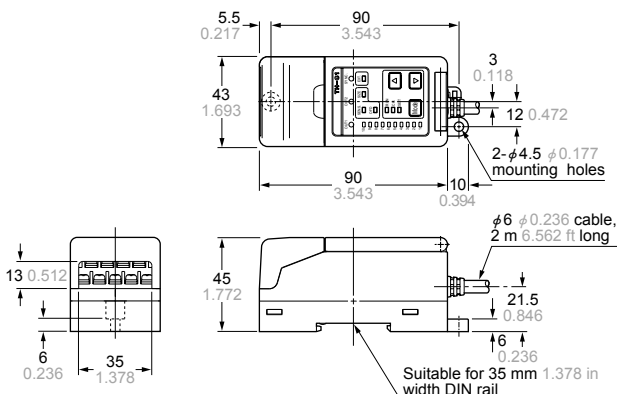

TH-12CS TH-12CPS Long sensing range type

Sensor head / TH-12

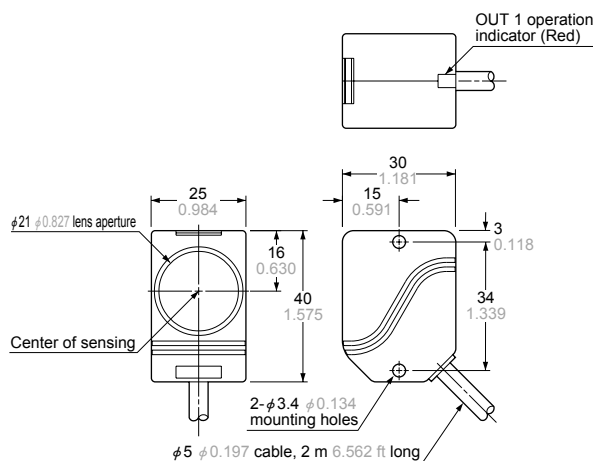

Controller / TH-C2, TH-C2P

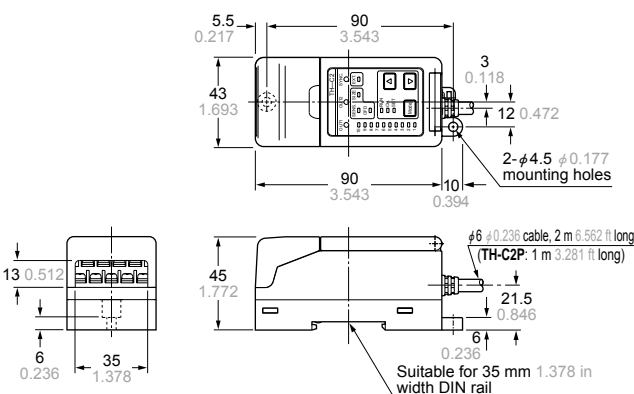

MS-TH-1 Sensor head mounting bracket for spot type (Accessory for TH-11)

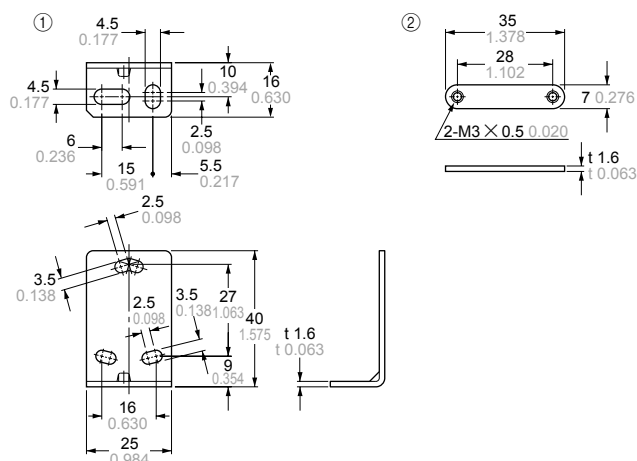

Material: Cold rolled carbon steel (SPCC)
Two M3 (length 25 mm 0.984 in) screws with washers are attached.

Assembly dimensions

The drawing below shows MS-TH-1 mounted on TH-11 fitted with heat shield TH-B1 (accessory).

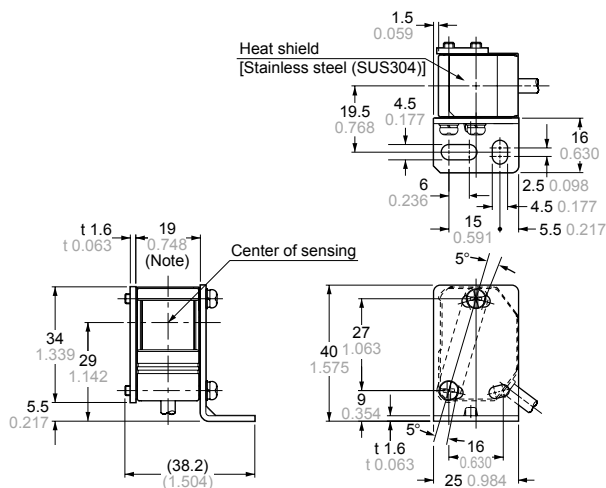

Note: 18 mm 0.709 in when the heat shield is not used.

DIMENSIONS (Unit: mm in) The CAD data in the dimensions can be downloaded from the SUNX website:

MS-TH-2

Sensor head mounting bracket for long sensing range type (Accessory for TH-12)

Assembly dimensions

The drawing below shows **MS-TH-2** mounted on **TH-12** fitted with heat shield **TH-B2** (accessory)

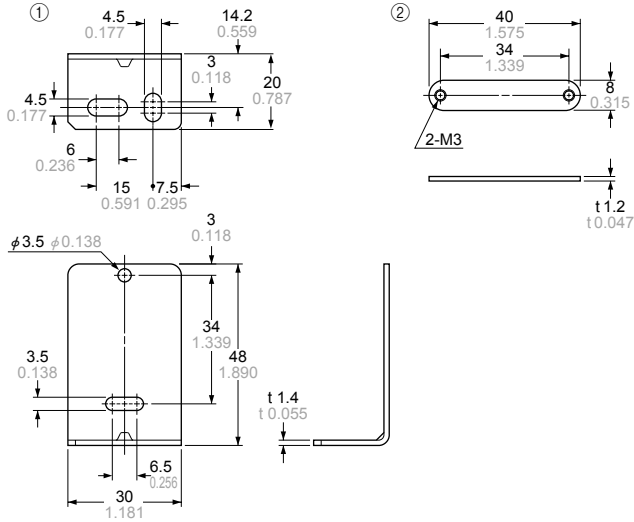

Material: Cold rolled carbon steel (SPCC)
Two M3 (length 30 mm 1.181 in) screws with washers are attached.

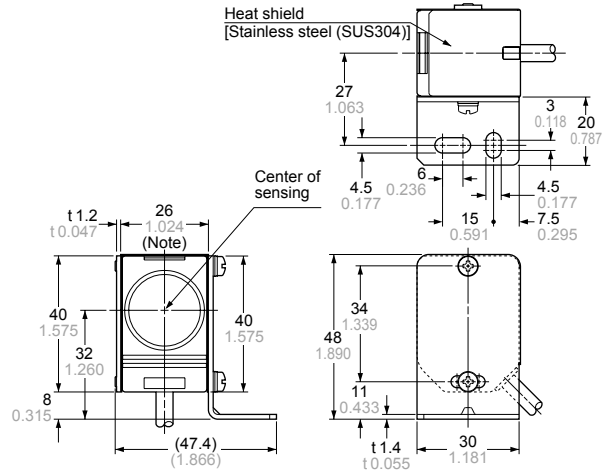

Note: 25 mm 0.984 in when the heat shield is not used.

OS-TH12

Slit mask for long sensing range type (Accessory for TH-12)

Assembly dimensions

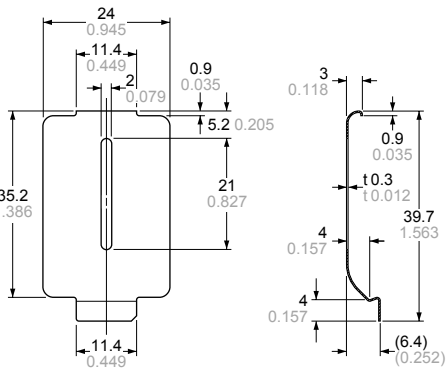

Material: Stainless steel (SUS304)

