

Using three-stage hybrid technology, this DIN rail mountable, single-pair, surge-suppressor attenuates over-voltage transients with gas tubes and silicon avalanche components while resettable fuses (PTCs) mitigate sneak currents. The PTC increases resistance by several orders of magnitude when over-currents exceed safe levels. A normal state resumes when over-currents are removed. The ability to self-restore in this manner significantly increases suppressor performance and survivability.

The STC-DRS Series mounts onto a standard 35 mm industrial DIN rail. There are three Field Side and three Electronics Side screw terminals. One is reserved for a shield. Three electrically tied ground terminals are provided for grounding the unit to building-approved ground. The shield is isolated from ground.

Features

- Low-voltage data surge protection
- Three-stage hybrid technology
- Sneak/fault current protection with resettable fuses (PTCs)
- Low-profile packaging
- Easy installation
- Fits standard 35 mm DIN rail
- Fast response time <1 nanosecond
- UL 497B Listed
- 5 Year Limited Warranty



Dimensions

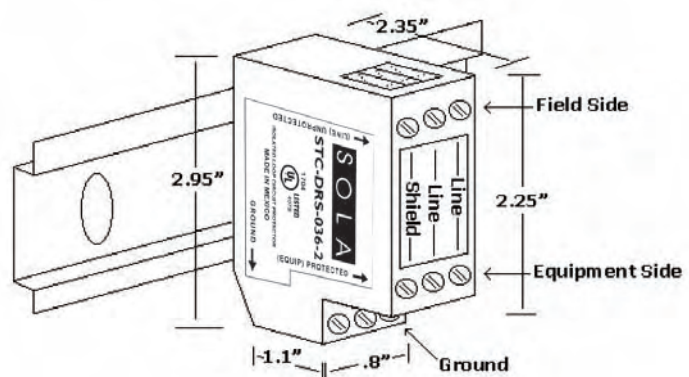

Notes:

These protectors are intended for indoor use on communication-loop circuits that have been isolated from the Public Switch Telephone Network.

The communication loop circuits shall not be exposed to accidental contact with the electric light or power conductors. The protectors shall be installed per the applicable requirements of the National Electric Code, ANSI/NFPA 70.

Selection Table

CATALOG NUMBER	MAX PEAK SIGNAL VOLTAGE	NOMINAL BREAKDOWN VOLTAGE	MAX CURRENT 1P 10X1000 MS (OCCURRENCES)	PEAK CURRENT 8X20 MS	TYP. CAP (PF)	MAX. CONTINUOUS CURRENT	NOMINAL SERIES RESISTANCE
STC-DRS-232	15	22	>100	10KA	1500	150ma	5 Ω
STC-DRS-036	30	36	>100	10KA	1500	150ma	5 Ω
STC-DRS-060	52	60	>100	10KA	1500	150ma	5 Ω