



Window Current Sensor

ECSW Series

Current Sensor



- Overcurrent & Undercurrent (Window Current) Sensing
- Adjustable Overcurrent & Undercurrent Trip Points
- Current Sensor is Included
- 10 A SPDT Isolated Output Contacts
- LED Indicators

Approvals:  

Selector Switch

ON ↔ OFF

- | | | |
|-----|--|--------------------|
| SW1 | | Not Used |
| SW2 | | Latched |
| SW3 | | Zero I |
| | | Output |
| | | Normally Energized |

Mode Selection Switches

- SW1 = Latched or Auto reset selector
 OFF - Automatic reset after a fault
 ON - Output relay latches after a fault trips the unit
- SW2 = Zero current detection - (below 250 mA)
 OFF - Zero current detection disabled
 ON - Zero current detection enabled
- SW3 = Output during normal operation
 OFF - Output relay de-energized
 ON - Output relay energized

Description

The ECSW Series of single phase, AC window current sensors includes adjustable overcurrent and undercurrent trip points. Detects locked rotor, a jam, loss of load, an open heater or lamp load, a broken belt, or loss of suction. LED's aid in trip point adjustment and provide fault indication. The built-in toroidal sensor eliminates the need for an external current transformer. The output can be electrically latched after a fault, or automatically reset. Remote resetting of a latched output by removing input voltage. The unit includes switch selectable zero current detection and normally de-energized or energized output operation. Time delays are included to improve operation and eliminate nuisance tripping.

Operation

When the input voltage is applied, sensing delay on startup begins and the output transfers (if normally energized is selected). Upon completion of the startup delay, sensing of the monitored current begins. As long as current is above undercurrent trip point and below the overcurrent trip point (inside the window), the output remains in its normal operating condition and both red LED's are OFF. The green LED glows when the output is energized. If current varies outside the window, the associated red LED glows, and the trip delay begins. If the current remains outside the window for the full trip delay, the relay transfers to fault condition state. If the current returns to normal levels (inside the window) during the trip delay, the red LED goes OFF, the trip delay is reset, and the output remains in the normal condition.

Reset: Remove input voltage or open latch switch. If zero current detection is selected, the unit will reset as soon as zero current is detected.

Operation With Zero Current Detection Enabled: If the current decreases to zero within the trip delay period, then zero current is viewed as an acceptable current level. The unit's output remains in its normal operating state. This allows the monitored load to cycle ON and OFF without nuisance tripping the ECSW. Zero current is defined as current flow of less than 250 milliamp-turns. Note: When zero current detect is selected, the latching operation of switch SW2 is canceled; the output will not latch after a fault trip.

Notes on Operation:

- 1) There is no hysteresis on the trip points. The overcurrent and undercurrent trip points should be adjusted to provide adequate protection against short cycling.
- 2) If the upper set point is set below the lower set point, both red LED's will glow indicating a setting error.
- 3) If zero current detection is selected (SW2 ON), and the system is wired to disconnect the monitored load, the system may short cycle. After the unit trips, the load de-energizes, and zero current is detected. The ECSW resets, and the load energizes again immediately and may be short cycled.
- 4) The sensing delay on start up only occurs when input voltage is applied. When zero current detection is selected, the trip delay must be longer than the duration of the inrush current or the unit will trip on the inrush current.

Typical Pump or Fan Protection Circuit Operation

Window Current Sensing: With the ECSW connected as shown in the diagram, a load may be monitored and controlled for over and under current. The ECSW Series' on board CT (CS) may be placed on the line or load side of the contactor. The ECSW selection switches are set for zero current sensing (see Selector Switch SW2) and the output selection is normally de-energized (see Selector Switch SW3). The input voltage (V) is applied to the ECSW continually. As the control switch (FSW) is closed, the input voltage (V) is applied to the motor contactor coil (MCC), and the motor (M) energizes. As long as the current remains below the overcurrent and above the undercurrent trip points, the ECSW's output contacts remain de-energized. If the load current should rise above or fall below a trip point, for the full trip delay, the normally open (NO) contact will close, energizing the control relay (CR) coil. The CR normally closed contact (CR1) opens and the MCC de-energizes and CR latches on through its normally open contacts (CR2). Reset is accomplished by momentarily opening the normally closed reset switch (RSW).

Connection

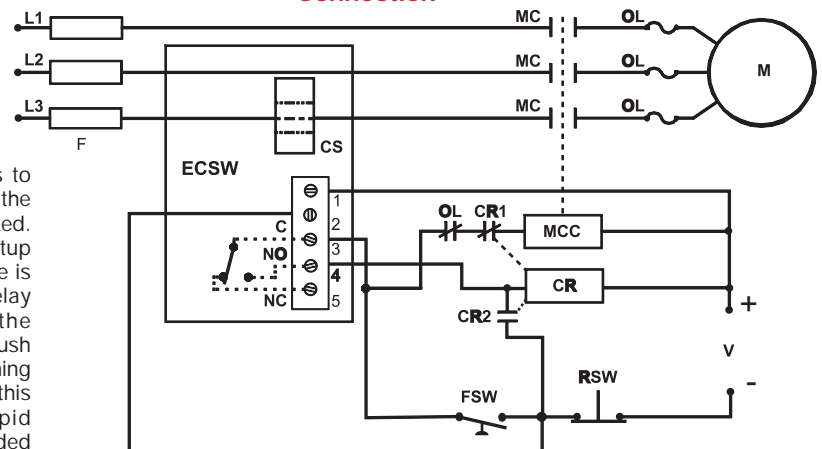

MC = Motor Contactor M = Motor F = Fuses
 OL = Overload RSW = Reset Switch
 FSW = Fan or Float Switch CR = Control Relay
 CS = Current Sensor MCC = Motor Contactor Coil

Note: The output is normally de-energized.

Note: If the current falls to zero within the trip delay, the ECSW remains de-energized. The sensing delay on startup occurs when input voltage is applied therefore trip delay must be longer than the duration of the motor's inrush current. The external latching relay CR2 is required in this system to prevent rapid cycling. A timer can be added to provide an automatic reset.

Window Current Sensor

ECSW Series

Current Sensor

Technical Data

Sensor		
Type	Toroid, through hole wiring for up to #4 AWG (21.1 mm ²) THHN wire	
Mode	Over and under current trip points (window current sensing)	
Trip Point Range	0.5 ... 50 A in 3 adjustable ranges	
Tolerance	Guaranteed range	
Maximum Allowable Current	Steady - 50 A turns; Inrush - 300 A turns for 10 s	
Trip Point vs. Temperature & Voltage	+/-5%	
Response Time	≤ 75 ms	
Frequency	45 ... 500 Hz	
Type of Detection	Peak detection	
Zero Current Detection	< 250 mA turns typical	
Time Delay		
Range	0.15 ... 50 s in 2 adjustable ranges or 0.08 ... 50 s fixed	
Tolerance	Adjustable: guaranteed range; Fixed: +/-10%	
Sensing Delay On Start Up	Fixed ≅ 0.1 ... 6 s in 1 s increments	
Tolerance	+40% -0%	
Delay vs. Temperature & Voltage	+/-15%	
Input		
Voltage	24, 120, or 230 V AC; 12 or 24 V DC	
Tolerance	12 V DC & 24 V DC/AC	-15% ... +20%
	120 & 230 V AC	-20% ... +10%
AC Line Frequency	50 ... 60 Hz	
Output		
Type	Electromechanical relay	
Mode: Switch selectable	ON -	Energized during normal operation, de-energized after a fault
	OFF -	De-energized during normal operation, energizes during a fault
Form	Isolated, SPDT	
Rating	10 A resistive at 240 V AC; 1/4 hp at 125 V AC; 1/2 hp at 250 V AC	
Life	Mechanical: 1 x 10 ⁶ ; Electrical: 1 x 10 ⁵	
Latch	Type	Electrical
	Reset	Remove input voltage
	Function	Switch selectable latching function
Protection		
Surge	IEEE C62.41-1991 Level A	
Circuitry	Encapsulated	
Isolation Voltage	≥ 2500 V RMS input to output	
Insulation Resistance	≥ 100 MΩ	
Mechanical		
Mounting	Surface mount with two #6 (M3.5 x 0.6) screws	
Termination	0.197 in. (5 mm) terminal blocks for up to #12 (3.2 mm ²) AWG wire	
Environmental		
Operating Temperature	-40° C ... +60° C	
Storage Temperature	-40° C ... +85° C	
Humidity	95% relative, non-condensing	
Weight	≅ 6.4 oz (181 g)	

Connection

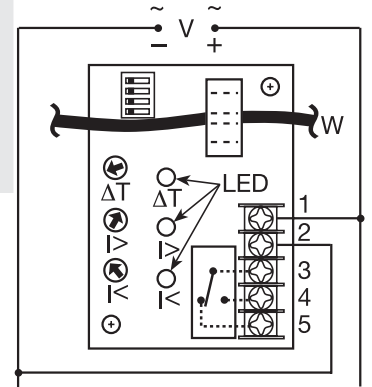

V = Voltage W = Monitored Wire
 ΔT = Adjustable Trip Delay
 I> = Adjustable Overcurrent
 I< = Adjustable Undercurrent

Mechanical View

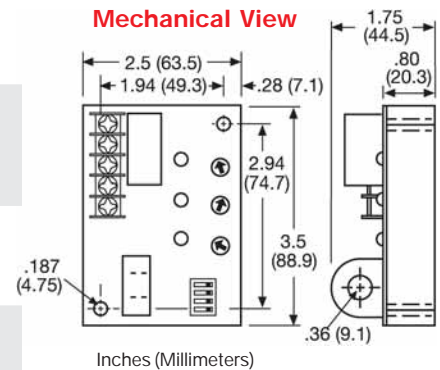

Inches (Millimeters)

8

Ordering Table

<p>ECSW</p> <p>Series</p>	<p>X</p> <p>Input</p> <p>-1 - 12 V DC</p> <p>-2 - 24 V AC</p> <p>-3 - 24 V DC</p> <p>-4 - 120 V AC</p> <p>-6 - 230 V AC</p>	<p>X</p> <p>Trip Point Range</p> <p>Adjustable Ranges</p> <p>-L - 0.5 ... 5 A</p> <p>-M - 2 ... 20 A</p> <p>-H - 5 ... 50 A</p>	<p>X</p> <p>Trip Delay</p> <p>-A - Adjustable 0.15 ... 7 s</p> <p>-B - Adjustable 0.5 ... 50 s</p> <p>-F - Fixed*</p>	<p>X</p> <p>Sensing Delay on Start Up</p> <p>-B - 0.1 s</p> <p>-C - 1 s</p> <p>-D - 2 s</p> <p>-E - 3 s</p> <p>-F - 4 s</p> <p>-G - 5 s</p> <p>-H - 6 s</p>	<p>X</p> <p>Connection</p> <p>-T - Terminal Blocks</p>
----------------------------------	--	--	--	--	---

Example P/N: **ECSW4LBCT** Fixed - **ECSW4HF10DT**

*If Fixed Delay is selected, insert delay [0.08 ... 50] in seconds. 0.1 ... 2 s in 0.1 s increments; 2 ... 50 s in 1 s increments

ECSW2B01 12.12.05