

# Single-Phase PumpSaver®Plus

## Model 111-Insider-P



Picture may not be representative of actual product.

The Model 111-Insider-P single-phase PumpSaver®Plus fits inside 1/3 and 1/2 hp 115V control boxes. The PumpSaver®Plus Model 111-Insider-P is designed to protect single-phase pumps from dry well, dead head, jammed impeller and over and undervoltage conditions.

A calibration adjustment allows the Insider-P to be calibrated to your specific pumping applications, thereby reducing the possibility of false or nuisance tripping. A unique microcontroller-based voltage and current sensing circuit constantly monitors the incoming power for fluctuations, overcurrent and undercurrent. When an abnormality, such as loss of suction is detected, the PumpSaver®Plus deactivates its output relay and directly disconnects the pump motor. The PumpSaver®Plus then begins its user-selectable restart delay (dry-well recovery) timer. When the timer counts down to zero or power is removed and re-applied, the PumpSaver®Plus reactivates its output relay, allowing the pump to turn back on.

The 111-Insider-P communicates with a hand-held diagnostics tool called the Informer (sold separately). The Informer displays 15 parameters including calibration points, trip points, running points, and last faults. An IR Kit-12 (12" fiber optic kit) is included with each 111-Insider-P, allowing the Informer to access these parameters even when the 111-Insider-P is enclosed in a control box. This is valuable for troubleshooting the pump while it is running.

NOTE: The PumpSaverPlus models have a sensitivity adjustment for the dry-well trip point. After calibration is done, you can adjust the sensitivity for the dry-well/dead-head trip point from 70-90% of the full load. This makes the unit even more adaptable to varying pumping applications. If you have a very low producing well, you increase the sensitivity closer to the 90% mark, or if you have a very heavy producing well, you would decrease the sensitivity around the 70% mark.

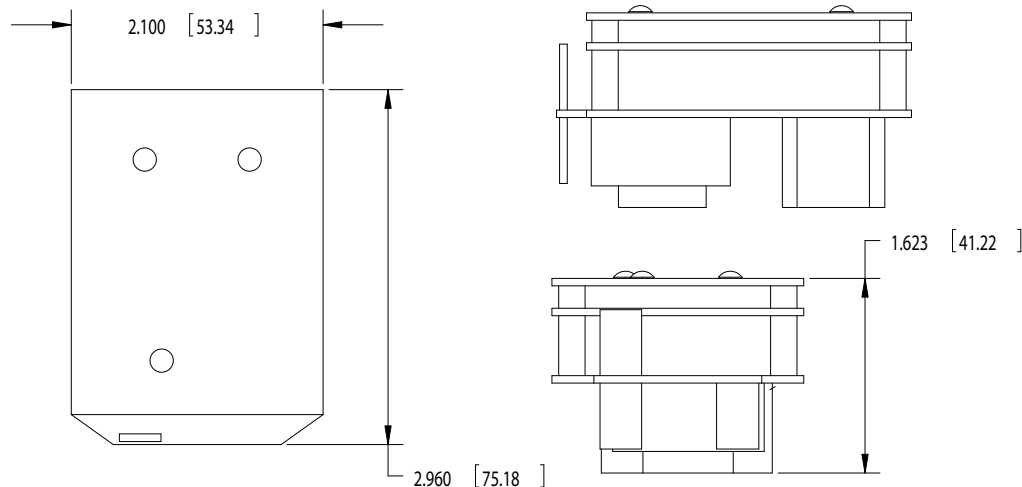

## Specifications

<b>Functional Specifications</b>	
Adjustments/Settings	
Overcurrent	125% of calibration point
Underload (dry-well)	Adjustable (70 to 90% of calibrated run power)
Overvoltage	132.5VAC
Undervoltage	95VAC
Number of restarts allowed in a 60-second period (rapid-cycling)	4
Trip Delay Times	
Overcurrent	5 seconds
Dry-well	4 seconds
Restart Delay Times	
Over/undervoltage	2 seconds
All other faults	Manual, 2-225 minutes
<b>Input Characteristics</b>	
Supply Voltage	115VAC
Load Range	1/3 - 1/2 hp
Frequency	50/60Hz (Note: 50Hz will increase all delay timers by 20%)
<b>Output Characteristics</b>	
Output Contact Rating-SPST	1/2hp@120VAC (17 amps max.)
<b>General Characteristics</b>	
Operating Temperature	-40° to 55° C (-40° to 131° F)
Maximum Input Power	5 W
Standards Passed	
Electrostatic Discharge (ESD)	IEC 61000-4-2, Level 2, 4kV contact, 6kV air
Surge Immunity	IEC 61000-4-5, Level 4, 4kV line-to-line and line-to-ground
Safety Marks	
cUR*	UL508, C22.2 No. 14
Weight	10 oz.
Mounting Methods	Inside a Franklin™, Pentek™, or CentriPro™ control box

\* The 111-Insider-P is approved by UL for use in the Franklin™, Pentek™ and CentriPro™ type 3R control boxes when installed properly. It is not intended to provide overload protection and should be used with thermally or impedance protected motors only.

### How to order:

Part Number: 111-Insider-P

