

Alternating Relay

Model ALT-XXX-3-SW



Features:

- Three float inputs (lead, lag, stop)
- Debounce time delay (5 seconds)
- LED load indicators
- Built-in switch to manually force a specific load (pump) to operate
- UL508 listed
- CE marked
- 8-pin plug in; DIN rail or surface mount
- 5-year warranty
- Made in the USA

Alternating relays are used to alternate between two loads and are commonly used in duplex pump-up and pump-down applications to balance the runtime of both pumps.

The ALT-xxx-3-SW alternating relays are 8-pin octal base plug-ins, available in two different single-phase voltage ranges. The ALT-100-3-SW is used for 95-120VAC applications and the ALT-200-3-SW is used for 190-240VAC applications. Both models are designed for three float inputs (lead, lag and stop floats). The lead and lag floats actuate latching relays that release when the stop float actuates. The units feature two LEDs to indicate the energized load(s).

The ALT relays have a built-in debounce time delay that prevents the relay from changing state if the float momentarily bounces, and they have a built-in switch to manually force a specific load (pump) to operate each time the input float closes. This is helpful when performing periodic maintenance or pump repair.



Specifications

Functional Characteristics	
Debounce Time Delay	5 seconds
Input Characteristics	
Supply Voltage ALT-100-3-SW ALT-200-3-SW	95-120VAC 190-240VAC
Frequency	50/60 Hz
Output Characteristics	
Output Contact Rating - DPDT Pilot Duty General Purpose	480VA @ 240VAC 10A @ 240VAC
General Characteristics	
Ambient Operating Temperature	-40° to 70° C (-40° to 158° F)
Maximum Input Power	5 W
Relative Humidity	10-95%, non-condensing per IEC 68-2-3
Terminal Torque	12 in.-lbs.
Wire Gauge	12-22 AWG Solid or stranded
Standards Passed	
Electrostatic Discharge (ESD)	IEC 61000-4-2, Level 3, 6kV contact, 8kV air
Radio Frequency Immunity (RFI), Radiated	150MHz, 10V/m
Fast Transient Burst	IEC 61000-4-4, Level 3, 3.5kV input power and controls
Surge Immunity	
IEC	IEC 61000-4-5, Level 3, 4kV line-to-line; Level 4, 4kV line-to-ground
ANSI/IEEE	C62.41 Surge and Ring Wave Compliance to a level of 6kV line-to-line
Hi-potential Test	Meets UL508 (2 x rated V + 1000V for 1 minute)
Safety Marks	
UL listed (OT08 octal socket required)	UL508 (File #E68520)
CE	IEC 60947-6-2
Dimensions	2.330" H x 2.375" W x 4.125" D (with socket)
Weight	9 oz.
Mounting Method	Plugs into 8-Pin OT08 Socket; DIN Rail or surface mount

Enclosure Dimensions

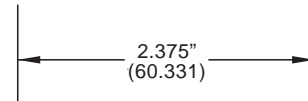
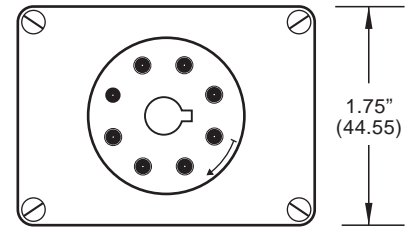

BOTTOM

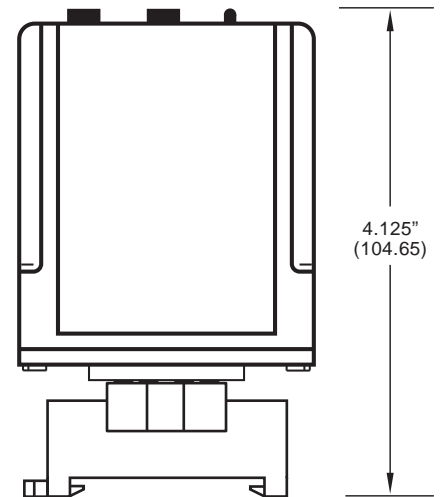

**SIDE
WITH OT08* SOCKET**

How to order:

Part Number: ALT-100-3-SW
ALT-200-3-SW

