

Features

Recordable voltage, current, last 4 faults, KWh usage, and power factor is available when using communications package.

Digitally programmable for precise customizing.

Sixteen set points can be programmed for maximum protection.

Last fault memory provides instant troubleshooting diagnostics.

Fast linear trip can prevent mechanical damage.

RS485 communication port for use with computerized systems using Modbus protocol.



Applications

The Model 777-FT can be used on any three phase motor drawing from 2-800 amps. It's linear trip feature can be set to trip in as little as 320ms, allowing one to protect mechanical drives from breaking chains, shear pins, etc. This product has been specifically designed for waste water, conveyor, lift gate and other applications where shock relays are used.

Description

The Model 777-FT is a fully-programmable electronic overload relay. An alphanumeric LED display provides programming and diagnostic information. Sixteen parameters can be programmed in the Model 777-FT:

- | | |
|--------------------------------------|---|
| 1) Low Voltage Set Point | 9) Rapid Cycle Timer (RD1) |
| 2) High Voltage Set Point | 10) Overload Restart Delay (RD2) |
| 3) Voltage Unbalance Set Point | 11) Underload Restart Delay (RD3 - Dry Well Recovery Timer) |
| 4) CT Size/Loop Setting | 12) No. of restarts after an overload (Manual or Automatic) |
| 5) Overcurrent Trip Point | 13) RS485 Address |
| 6) Undercurrent Trip Point | 14) No. of restarts after an underload fault |
| 7) Current Unbalance Trip Point | 15) Underload Trip Delay |
| 8) Trip Class (5,10,15,20,30) Linear | 16) Ground Fault Trip Point |

An RS-485 port allows the Model 777-FT to be connected to an RM-2000 remote monitor or directly to a computer or PLC. The RM-2000/777-FT motor management system combines unsurpassed electronic motor protection and critical, user friendly motor monitoring. SymCom's Solutions Software (sold separately) can be used to monitor and control up to 99 Model 777-FTs from a central computer. Using Solutions Software, an operator can control motors, view the operating parameters, and record the following operating parameters:

- | | |
|-------------------------------------|-----------------------------|
| • Line - Line Voltages (Recordable) | • Restart Delay Timers |
| • Line Currents (Recordable) | • KWH Usage (Recordable) |
| • Last 4 Faults (Recordable) | • Power Factor (Recordable) |

MotorSaver
THREE-PHASE ELECTRIC
MOTOR PROTECTOR

Model 777-FT
Model 777-LR-FT
Model 777-575-FT

Overload Relays

**Engineered
Protection**

**Protects 3-Phase
motors from:**

- Overload
- Underload
- Jams
- Under Voltage
- Over Voltage
- Single Phasing
- Unbalance (Voltage & Current)
- Ground Fault (Class II)
- Rapid Cycling
- Phase Reversal

Additional Features

- Fully Programmable
- UL and cUL Listed
- CE Compliant
- CSA Approved
- Automatic or Manual Reset
- Tamper Guard
- RS485 Communications Port
- Surface Mount or DIN Rail Mount
- Alphanumeric LED Diagnostic Display
- Last Fault Memory
- 5 Year Warranty
- Made in USA

New Features

- Network Programmable
- Ability to clear last fault



MotorSaver®

THREE-PHASE ELECTRIC MOTOR PROTECTOR

Specifications
 Operating Points
 Special Options

777-FT • 777-LR-FT • 777-575-FT
 Overload Relays



TYPICAL WIRING DIAGRAM FOR MODEL 777 (20 TO 90 AMPS)

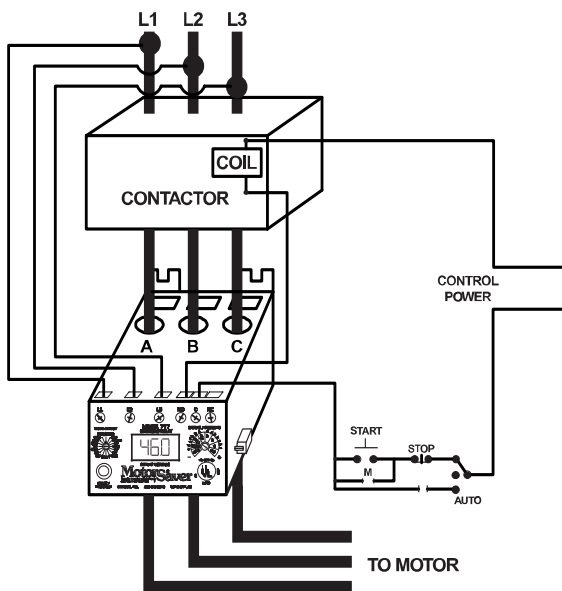

CURRENT TRANSFORMER WIRING DIAGRAM FOR MODEL 777 (80 TO 800 AMPS)

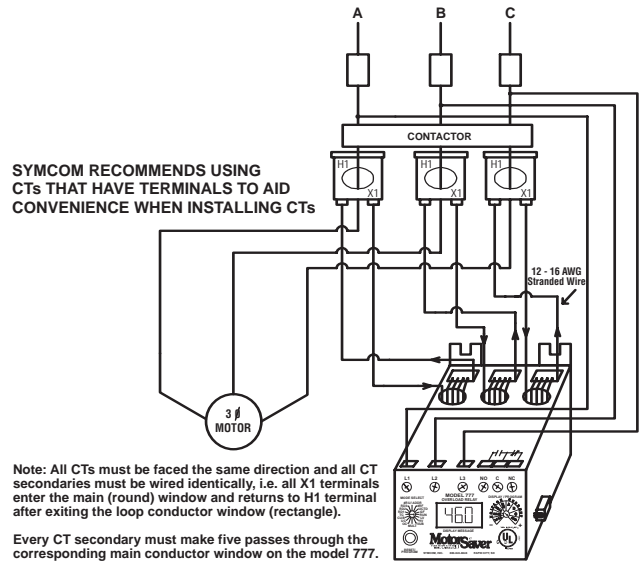

Wiring configuration based on motor amps.

Model	Full Load Amps	# of Loops	# of Conductors through A, B and C	MULT to Program (CT Ratio)
777-LR	1 - 2	1	2	2
	2 - 9	0	1	1
777-FT	8 - 12	2	3	3
	12 - 25	1	2	2
	25 - 90	0	1	1
External CTs required. See wiring diagram for external CTs	80 - 110	4	5	100 (100:5)
	110 - 160	4	5	150 (150:5)
	160 - 220	4	5	200 (200:5)
	220 - 320	4	5	300 (300:5)
	320 - 420	4	5	400 (400:5)
	400 - 520	4	5	500 (500:5)
	480 - 600	4	5	600 (600:5)
	560 - 800	4	5	800 (800:5)

Overload Trip Classes

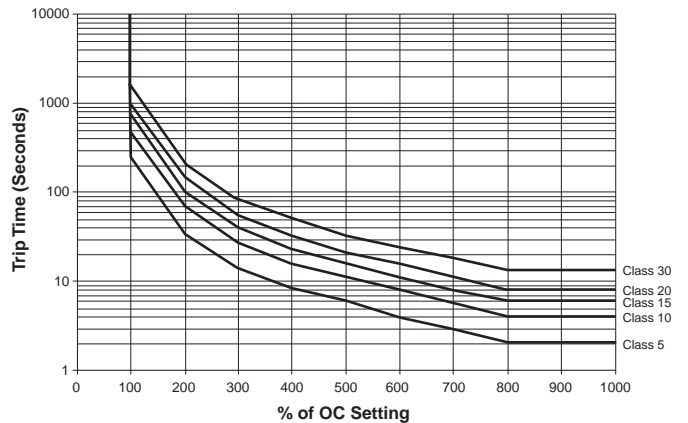

MotorSaver®

THREE-PHASE ELECTRIC MOTOR PROTECTOR

Specifications
 •
 Operating Points
 •
 Special Options

777-FT • 777-LR-FT • 777-575-FT
 Overload Relays



Model 777-FT Overloads are fully programmable three phase electronic overload relays. They can be used as a stand alone product or networked via the Modbus RS-485 port. A computer, PLC or other control device can be used to monitor and control the Model 777-FT overload relays.

The Model 777-FT includes three built-in current transformers (CTs) which will handle applications up to 90 amps. External current transformers can be implemented to handle higher amperage applications.

The following 16 set points can be viewed from the three digit LED displays or from a networked computer: undervoltage trip point, overvoltage trip point, voltage unbalance trip point, CT size/loops setting, overcurrent trip point, undercurrent trip point, current unbalance trip point, overload trip class (5,10,15,20,30), rapid cycle timer (RD1), overload restart delay (RD2), underload restart delay (RD3), number of starts after an overload, voltage and current unbalance, single phasing (manual or automatic), RS485 address, number of restarts after an underload fault, underload trip delay, and ground fault trip point. Individual line voltages and current levels, as well as average voltage and average current, can also be viewed while the motor is running.

*Contact SymCom for information on medium voltage applications.

Dimensions for All 777 Units

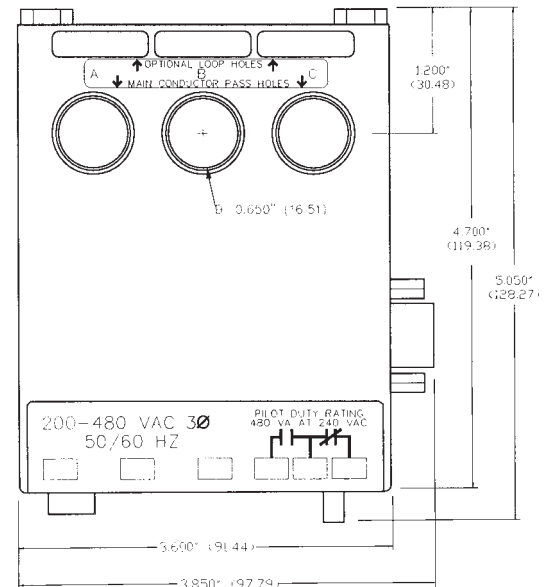
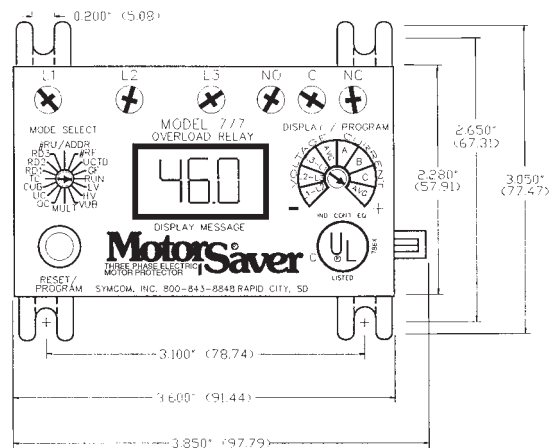



*Specifications
Model 777-FT,
Model 777-LR-FT &
Model 777-575-FT*

Electrical	
Input Voltage	200-480 VAC, 3Ø(Standard) 500-600VAC for model 777-575
Frequency	50-60 Hz
Motor Full Load Amp Range 777, 777-575 2-25 Amps, 3Ø (Loops Required) 25-90 Amps, 3Ø(Direct) 80-800 Amps, 3Ø(External CTs)	777-LR, 777-575-LR 1-4.5 Amps, 3Ø(Loops Required) 2-9 Amps, 3Ø(Direct)
Short Circuit Rating	10kA
Power Consumption	10W (Maximum)
Output Contact Rating SPDT (Form C)	Pilot duty rating: 480 VA @ 240 VAC General purpose: 10A @ 240 VAC
Expected Life	
Mechanical	1 x 10 ⁶ operations
Electrical	1 x 10 ⁶ operations at rated load
Accuracy at 25° C (77° F)	
Voltage	±1%
Current	±3%(<100 Amps Direct)
GF Current	±15%
Timing	5% ± 1 second
Repeatability	
Voltage	± 0.5% of nominal voltage
Current	± 1% (<100 amps direct)
Trip Times (Those not shown have user selectable trip times.)	
Ground Fault Trip Time 101%-200% of Setpoint 201%-300% of Setpoint 301%-400% of Setpoint 401% or Greater	Trip time 8 seconds ± 1 second 4 seconds ± 1 second 3 seconds ± 1 second 2 seconds ± 1 second
Current Unbalance Trip Times	
% Over Setpoint	Trip time
1%	30 seconds
2%	15 seconds
3%	10 seconds
4%	7.5 seconds
% Over Setpoint	Trip time
5%	6 seconds
6%	5 seconds
10%	3 seconds
15%	2 seconds
Safety Marks	
UL	UL508, UL1053
CE	IEC 60947-1, IEC 60947-5-1
Standards Passed	
Electrostatic Discharge (ESD)	IEC 1000-4-2, Level 3, 6kV contact, 8kV air
Radio Frequency Immunity (RFI), Conducted	IEC 1000-4-6, Level 3 10V/m
Radio Frequency Immunity (RFI), Radiated	IEC 1000-4-3, Level 3 10V/m
Fast Transient Burst	IEC 1000-4-4, Level 3, 3.5 kV input power
Surge	
IEC	1000-4-5 Level 3, 2kV line-to-line; Level 4, 4kV line-to-ground
ANSI/IEEE	C62.41 Surge and Ring Wave Compliance to a level of 6kV line-to-line
Hi-potential Test	Meets UL508 (2 x rated V +1000V for 1 minute)
Vibration	IEC 68-2-6, 10-55Hz, 1mm peak-to-peak, 2 hours, 3 axis
Shock	IEC 68-2-27, 30g, 3 axis, 11ms duration, half-sine pulse
Mechanical	
Dimensions	3.1"H x 5.1"D x 3.9"W
Terminal Torque	7 inch*lb
Enclosure Material	Polycarbonate
Weight	1.2lbs
Maximum Conductor Size Through 777	0.65" with insulation
Environmental	
Temperature Range	Ambient Operating: -20° - 70° C (-4° - 158° F) Ambient Storage: -40° - 80° C (-40° - 176° F)
Pollution Degree	3
Class of Protection	IP20, NEMA 1
Relative Humidity	10-95%, non-condensing per IEC 68-2-3
Programmable Operating Points	
	Range
LV- Low Voltage Threshold	170V (450V*) - HV Setting
HV- High Voltage Threshold	LV Setting - 528V (660V*)
VUB- Voltage Unbalance Threshold	2 - 15% or 999
MULT- # of Conductors or CT Ratio (XXX:5)	1-10 Conductors or 100-800 Ratio
OC- Over Current Threshold	(20 to 100A) ÷ MULT or 80 to 120% of CT Primary; LR, (2 to 10A) ÷ MULT
UC- Under Current Threshold	(0, 10 to 98A) ÷ MULT or 40 to 100% of CT Primary; LR, (0, 1 to 9.8A) ÷ MULT
CUB- Current Unbalance Threshold	2 - 25% or 999
TC- Over Current Trip Class **	5, J5, 10, J10, 15, J15, 20, J20, 30, J30, J00 (J00 = Linear)
RD1- Rapid Cycle Timer	0, 2 - 500 Seconds (x 0.5 if TC = J00)
MA- Motor Acceleration Timer	(0 to 500) x 0.158 Seconds = (0 to 79 Seconds)
RD2- Restart Delay After All Faults Except Under Current (motor cool down timer)	2 - 500 Minutes (x 0.5 if TC = J00)
OCTD - Overcurrent Trip Delay (Linear)	(2 to 500) x 0.158 Seconds = (0.32 to 79 Seconds)
RD3- Restart Delay After Under Current (dry well recovery timer)	2 - 500 Minutes (x 0.5 if TC = J00)
#RU- Number of Restarts After Under Current	0, 1, 2, 3, 4, A(Automatic)
ADDR- RS485 Address	A01- A99
#RF-Number of Restarts After All Faults Except Undercurrent***	0, 1, oc1, 2, oc2, 3, oc3, 4, oc4, A, ocA
UCTD- Under Current Trip Delay	2 - 60 Seconds
GF- Ground Fault Current Threshold	(3 to 20A) ÷ MULT or 10 to 30% of CT Primary or OFF; LR, (0.3 to 2.0A) ÷ MULT or OFF

NOTES: SymCom's 777-FT & 777-LR-FT can be preprogrammed prior to installation by applying 120 VAC between the L1 and L2 terminals.

* 575 volt Model (MS 777-575-FT)

** If J prefix is displayed in trip class setting, jam protection is enabled.

*** If "oc" is disabled in the #RF setting, the overcurrent will be included as a normal fault and the relay will automatically restart after RD2 expires, otherwise, manual reset is required after an overcurrent fault.

SymCom warrants its microcontroller based products against defects in material or workmanship for a period of five (5) years from the date of manufacture. All other products manufactured by SymCom shall be warranted against defects in material and workmanship for a period of two (2) years from the date of manufacture. For complete information on warranty, liability, terms returns, and cancellations, please refer to the SymCom Terms and Conditions of Sale document.