

Features

Recordable voltage, current, last 4 faults, KWh usage, and power factor is available when using communications package.

Digitally programmable for precise customizing.

Sixteen set points can be programmed for maximum protection.

Last fault memory provides instant troubleshooting diagnostics.

UL and cUL listed as an overload relay.

RS485 communication port for use with computerized systems using Modbus protocol.



MotorSaver
THREE-PHASE ELECTRIC
MOTOR PROTECTOR

Model 777
Model 777-LR
Model 777-575

Overload Relays

**Engineered
Protection**

Applications

The Model 777 can be used on any 3-phase motor drawing 2-800 amps. Applications include CONVEYOR SYSTEMS, HVAC EQUIPMENT, PUMPS, SAWS, GRINDERS AND OTHER 3-PHASE ELECTRIC MOTORS.

Description

The Model 777 is a fully-programmable electronic overload relay. An alphanumeric LED display provides programming and diagnostic information. Sixteen parameters can be programmed in the Model 777:

- | | |
|-----------------------------------|---|
| 1) Low Voltage Setpoint | 9) Rapid-Cycle Timer (RD1) |
| 2) High Voltage Setpoint | 10) Fault Restart Delay (RD2 - Motor Cool-down Timer) |
| 3) Voltage Unbalance Setpoint | 11) Underload Restart Delay (RD3 - Dry Well Recovery Timer) |
| 4) CT Size/Loop Setting | 12) No. of restarts after an overload (Manual or Automatic) |
| 5) Overcurrent Trip Point | 13) RS485 Address |
| 6) Undercurrent Trip Point | 14) No. of restarts after an underload fault |
| 7) Current Unbalance Trip Point | 15) Underload Trip Delay |
| 8) Trip Class (5, 10, 15, 20, 30) | 16) Ground Fault Trip Point |

Programming the Model 777 is an easy four step process: 1) Rotate the MODE SELECT switch to the parameter to be programmed; 2) Depress and hold the RESET/PROGRAM button; 3) Rotate the DISPLAY/PROGRAM dial to the desired setting as shown in the LED display; and 4) Release the RESET/PROGRAM button.

An RS-485 port allows the Model 777 to be connected to an RM-1000 or RM-2000 remote monitor or directly to a computer or PLC. The RM-2000/777 motor management system combines unsurpassed electronic motor protection and critical, user friendly motor monitoring. SymCom's Solutions Software (sold separately) can be used to monitor and control up to 99 Model 777s from a central computer. Using Solutions Software, an operator can control motors, view the operating parameters, and record the following operating parameters:

- Line - Line Voltages (Recordable)
- Line Currents (Recordable)
- Last 4 Faults (Recordable)
- Restart Delay Timers
- KWH Usage (Recordable)
- Power Factor (Recordable)

Protects 3-Phase motors from:

- Overload
- Underload
- Jams
- Undervoltage
- Overvoltage
- Single phasing
- Unbalance (voltage & current)
- Ground fault (Class II)
- Rapid cycling
- Phase reversal

Standard Features

- Fully programmable
- UL and cUL listed
- CE compliant
- CSA approved
- Automatic or manual reset
- Tamper guard
- RS485 communications port
- Surface mount or DIN rail mount
- Alphanumeric LED diagnostic display
- Last fault memory
- 5 year warranty
- Made in USA

New Features

- Network programmable
- Ability to clear last fault



Motorsaver[®]

THREE-PHASE ELECTRIC MOTOR PROTECTOR

Wiring Diagrams
•
Charts

777 • 777-LR • 777-575
Overload Relays



TYPICAL WIRING DIAGRAM FOR MODEL 777 (20 TO 90 AMPS)

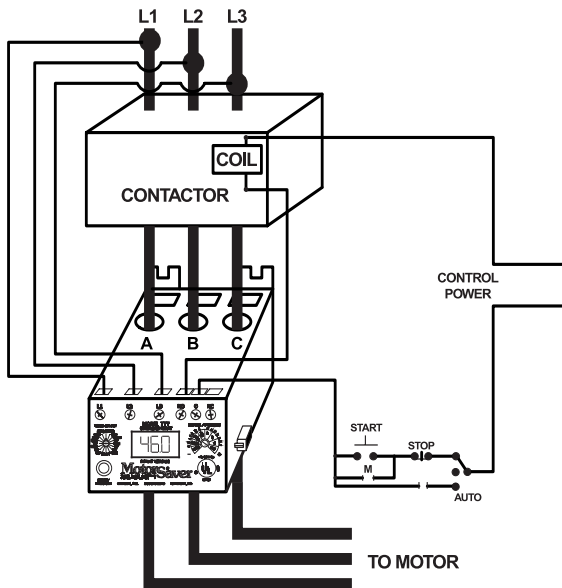

CURRENT TRANSFORMER WIRING DIAGRAM FOR MODEL 777 (80 TO 800 AMPS)

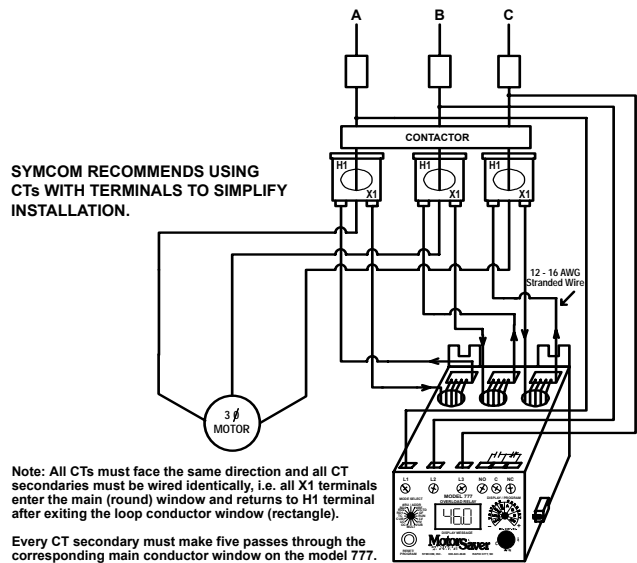

Wiring configuration based on motor amps.

Model	Full Load Amps	# of Loops	# of Conductors through A, B and C	MULT to Program (CT Ratio)
777-LR	1 - 2	1	2	2
	2 - 9	0	1	1
777	8 - 12	2	3	3
	12 - 25	1	2	2
	25 - 90	0	1	1
External CTs required. See wiring diagram for external CTs	80 - 110	4	5	100 (100:5)
	110 - 160	4	5	150 (150:5)
	160 - 220	4	5	200 (200:5)
	220 - 320	4	5	300 (300:5)
	320 - 420	4	5	400 (400:5)
	400 - 520	4	5	500 (500:5)
	480 - 600	4	5	600 (600:5)
	560 - 800	4	5	800 (800:5)

Overload Trip Classes

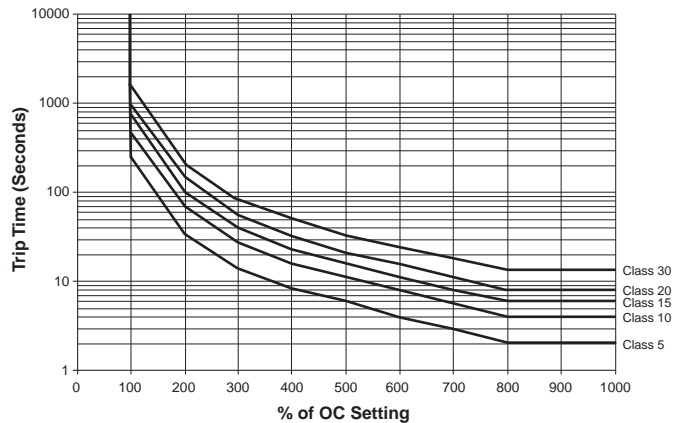

MotorSaver®

THREE-PHASE ELECTRIC MOTOR PROTECTOR

Accessories
•
Dimensions

777 • 777-LR • 777-575
Overload Relays



RS485MS-2W

The optional RS485MS-2W communications module is required if Model 777-type products are used on a Modbus network or with RM-1000 or RM-2000 remote displays. The communications module provides RS-485 bus drive capabilities and optical isolation from the overload electronics and powerline.

RM-1000

The RM-1000 is a local display/controller with RS-485 Modbus network capabilities. Its modular design allows for flexible, inexpensive installation yet provides robust motor management. Plant personnel safety is also enhanced by allowing system troubleshooting and control without opening the starter box.



RM-2000

The RM-2000 motor monitoring device used in conjunction with SymCom's Model 777 provides a complete motor management system. This system provides full electronic motor protection, historical data and critical, user-friendly motor-monitoring information. The RM-2000 also features a real-time clock, 2x20 backlit LCD, one upstream RS-485 Modbus communication port and is rated NEMA-3R when mounted on a panel door.



777 Manual Remote Reset Kit

The manual remote reset allows the 777 line of MotorSaver® and PumpSaver® products to be manually reset without opening the panel door. Simply connect the 9-pin adapter to the 777 communication port and mount the reset switch in a convenient location.

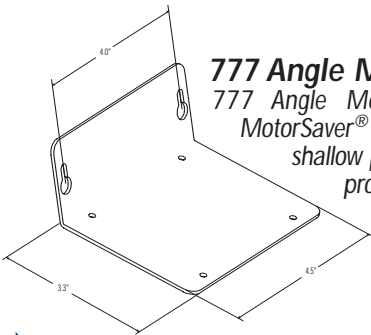

777 Angle Mounting Bracket

777 Angle Mounting Bracket allows the 777 line of MotorSaver® and PumpSaver® products to be mounted into shallow panels such as the Furnas Size 1 and other low profile panels. The angle bracket reduces the installed depth from 5.05" to 4.25".

Dimensions for All 777 Units

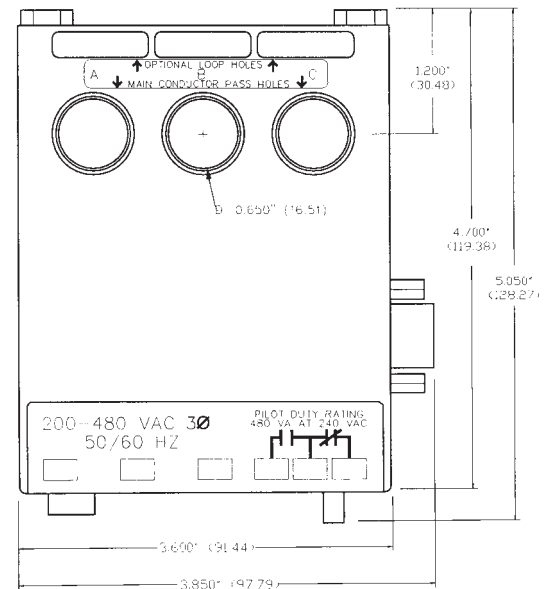
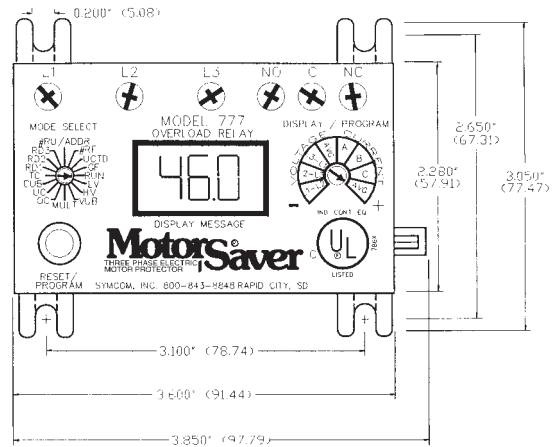



Specifications Model 777, Model 777-LR & Model 777-575

Electrical	
Input Voltage	200-480 VAC, 3Ø(Standard) 500-600VAC for model 777-575
Frequency	50-60 Hz
Motor Full Load Amp Range 777,777-575 2-25 Amps, 3Ø (Loops Required) 25-90 Amps, 3Ø(Direct) 80-800 Amps, 3Ø(External CTs)	777-LR, 777-575-LR 1-4.5 Amps, 3Ø(Loops Required) 2-9 Amps, 3Ø(Direct)
Short Circuit Rating	10kA
Power Consumption	10W (Maximum)
Output Contact Rating SPDT (Form C)	Pilot duty rating: 480 VA @ 240 VAC General purpose: 10A @ 240 VAC
Expected Life	
Mechanical	1 x 10 ⁶ operations
Electrical	1 x 10 ⁵ operations at rated load
Accuracy at 25° C (77° F)	
Voltage	±1%
Current	±3%(<100 Amps Direct)
GF Current	±15%
Timing	5% ± 1 second
Repeatability	
Voltage	± 0.5% of nominal voltage
Current	± 1% (<100 amps direct)
Trip Times (Those not shown have user selectable trip times.)	
Ground Fault Trip Time 101%-200% of Setpoint 201%-300% of Setpoint 301%-400% of Setpoint 401% or Greater	Trip time 8 seconds ± 1 second 4 seconds ± 1 second 3 seconds ± 1 second 2 seconds ± 1 second
Current Unbalance Trip Times	
% Over Setpoint	Trip time
1%	30 seconds
2%	15 seconds
3%	10 seconds
4%	7.5 seconds
% Over Setpoint	Trip time
5%	6 seconds
6%	5 seconds
10%	3 seconds
15%	2 seconds
Safety Marks	
UL	UL508, UL1053
CE	IEC 60947-1, IEC 60947-5-1
CSA	
Standards Passed	
Electrostatic Discharge (ESD)	IEC 1000-4-2, Level 3, 6kv contact, 8kv air
Radio Frequency Immunity (RFI), Conducted	IEC 1000-4-6, Level 3 10V/m
Radio Frequency Immunity (RFI), Radiated	IEC 1000-4-3, Level 3 10V/m
Fast Transient Burst	IEC 1000-4-4, Level 3, 3.5 kv input power
Surge	
IEC	1000-4-5 Level 3, 2kv line-to-line; Level 4, 4kv line-to-ground
ANSI/IEEE	C62.41 Surge and Ring Wave Compliance to a level of 6kv line-to-line
Hi-potential Test	Meets UL508 (2 x rated V +1000V for 1 minute)
Vibration	IEC 68-2-6, 10-55Hz, 1mm peak-to-peak, 2 hours, 3 axis
Shock	IEC 68-2-27, 30g, 3 axis, 11ms duration, half-sine pulse
Mechanical	
Dimensions	3.1"H x 5.1"D x 3.9"W
Terminal Torque	7 inch•lb
Enclosure Material	Polycarbonate
Weight	1.2 lbs
Maximum Conductor Size Through 777	0.65" with insulation
Environmental	
Temperature Range	Ambient Operating: -20° - 70° C (-4° - 158° F) Ambient Storage: -40° - 80° C (-40° - 176° F)
Pollution Degree	3
Class of Protection	IP20, NEMA 1
Relative Humidity	10-95%, non-condensing per IEC 68-2-3
Programmable Operating Points	
	Range
LV- Low Voltage Threshold	170V (450V*) - HV Setting
HV- High Voltage Threshold	LV Setting - 528V (660V*)
VUB- Voltage Unbalance Threshold	2 - 15% or 999
MULT- # of Conductors or CT Ratio (XXX:5)	1-10 Conductors or 100-800 Ratio
OC- Overcurrent Threshold	(20 to 100A) ÷ MULT or 80 to 120% of CT Primary; LR, (2 to 10A) ÷ MULT
UC- Undercurrent Threshold	(0, 10 to 98A) ÷ MULT or 40 to 100% of CT Primary; LR, (0, 1 to 9.8A) ÷ MULT
CUB- Current Unbalance Threshold	2 - 25% or 999
TC- Overcurrent Trip Class **	5, J5, 10, J10, 15, J15, 20, J20, 30, J30
RD1- Rapid Cycle Timer	0, 2 - 500 Seconds
RD2- Restart Delay After All Faults Except Undercurrent (motor cool down timer)	2 - 500 Minutes
RD3- Restart Delay After Undercurrent (dry well recovery timer)	2 - 500 Minutes
#RU- Number of Restarts After Undercurrent	0, 1, 2, 3, 4, A(Automatic)
ADDR- RS485 Address	A01- A99
#RF-Number of Restarts After All Faults Except Undercurrent***	0, 1, oc1, 2, oc2, 3, oc3, 4, oc4, A, ocA
UCTD- Undercurrent Trip Delay	2 - 60 Seconds
GF- Ground Fault Current Threshold	(3 to 20A) ÷ MULT or 10 to 30% of CT Primary or OFF; LR, (0.3 to 2.0A) ÷ MULT or OFF

SymCom warrants its microcontroller based products against defects in material or workmanship for a period of five (5) years from the date of manufacture. All other products manufactured by SymCom shall be warranted against defects in material and workmanship for a period of two (2) years from the date of manufacture. For complete information on warranty, liability, terms returns, and cancellations, please refer to the SymCom Terms and Conditions of Sale document.

NOTES: SymCom's 777 & 777-LR can be preprogrammed prior to installation by applying 120 VAC between the L1 and L2 terminals.
* 575 volt Model (MS 777-575)
** If J prefix is displayed in trip class setting, jam protection is enabled.
*** If "oc" is disabled in the #RF setting, the overcurrent will be included as a normal fault and the relay will automatically restart after RD2 expires, otherwise, manual reset is required after an overcurrent fault.