

The RM-2000 motor-monitoring device can be used to monitor and/or control SymCom's Model 777 via an RS-485 Modbus network. A second communication port allows monitoring and control of up to 99 RM-2000 devices from a computer with SymCom's Solutions software, or a PLC, DCS, or SCADA system. The RM-2000 is environmentally protected and can easily be mounted on the front of a panel or MCC.

The RM-2000 displays the following motor information:

- Real-time line currents, average current and current unbalance
- Current to ground
- Line-to-line voltages, average voltage and voltage unbalance
- Instantaneous power
- Power factor
- Last four faults
- All programmed 777 settings
- Remaining restart delay times

The RM-2000 is also equipped with a real-time clock, which allows access to the following motor management information:

- Total motor run-time (reset capable)
- Time and date of last four faults, with voltage and current at time of trip
- Time and date of last ten motor starts
- Total number of motor restarts (reset capable)
- Minimum time between any two starts with time and date
- Run-time since last start (reset capable)
- KWwhs consumed
- KVARs consumed



PART I – INSTALLATION AND OPERATION

FEATURES

The RM-2000 is a motor management device used in conjunction with any SymCom Model 777. The RM-2000 provides the following features:

Information Displayed

- **Run-Time Information:** the RM-2000 can display all of the information the Model 777 displays as well as information that the Model 777 maintains but does not display, such as current unbalance, voltage unbalance and power factor; see page 1 for a complete list of viewable parameters.
- **Real time clock:** the RM-2000 has a real-time clock so it can track time-dependent data such as power draw (kW), energy consumption (kWH), and run-hours.
- **Detailed information about fault conditions:** the RM-2000 can store information about power conditions just before the Model 777 tripped in addition to the date and time of the fault.
- **Historical data:** the RM-2000 can display historical data about the motor being monitored by the Model 777 such as the total number of starts, the number of trips, and the date and time of the last 10 starts.

Installation

- **Panel mounting:** a Model 777 is often mounted inside a motor control panel and its display is not visible. The RM-2000 can be mounted on the outside of the panel which allows all of the information from the Model 777 to be displayed.
- **Remote mounting:** the RM-2000 communicates with the Model 777 by an RS-485 cable which can be up to 4000 feet long. This allows the RM-2000 to remotely monitor a Model 777.
- **Ease of installation:** the RM-2000 only requires drilling 4 mounting holes and punching out a 2" OD round hole using a standard knock out punch or drilling a 1 15/16" – 2 3/16" hole for the terminals to protrude through to the inside of the panel.

INSTALLING THE RM-2000

1. Attach the template drawing to the panel where the RM-2000 is to be mounted.
2. Take caution when drilling the holes to mount the RM-2000. Use an 11/64" drill bit for the four corner mounting screws. Drill a 1 15/16" – 2 3/16" hole for the terminals to protrude through to the inside of the panel.
3. Verify the gasket is in place on the back of the RM-2000. Attach the RM-2000 to the panel using the four screws provided.
4. Run the appropriate wires to the back of the RM-2000 and terminate the wires in the provided screw-type, depluggable connectors; see the wiring diagram on the following page. This should include at least 120VAC control power, one set of communication wires to the 777, and ground wire to case ground on the panel.
5. It is important to have the A phase of the breaker connected to L1 on the 777, B phase to L2 and C to L3. Equally important, is to have the A phase conductor through the A phase hole, B through the B phase hole, and C through the C phase hole of the 777.
6. The 777, when used with the RM-2000, should be connected according to the following wiring diagram.

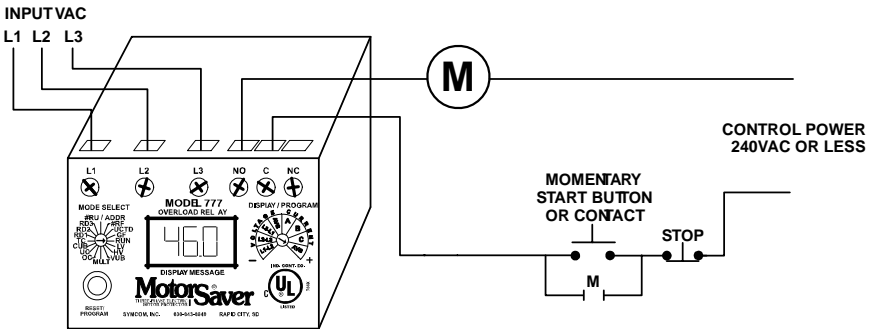

Figure 1: Typical 777 Wiring Diagram

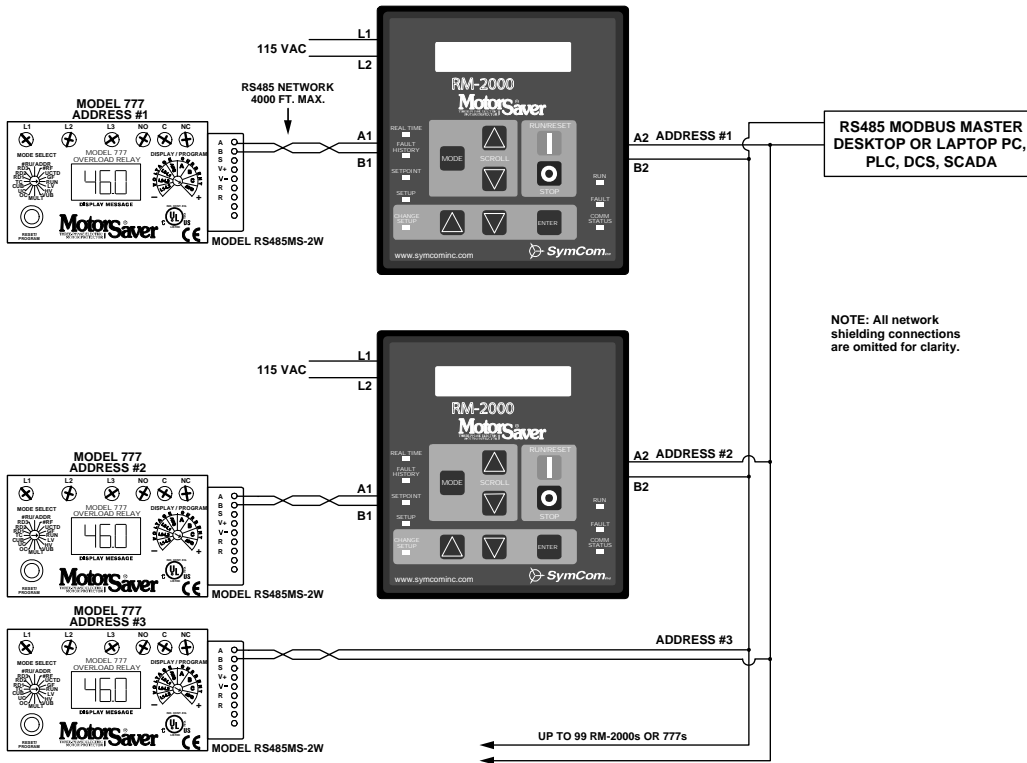

Figure 2: RM-2000 Wiring Diagram

COMMUNICATIONS

A **Model RS485MS-2W** communications module is required to connect the Model 777 to the RS-485 network. A shielded, twisted-pair cable connected to A and B of the RS485MS-2W must be connected to Comm Port 1 (A1 & B1) on the back of the RM-2000.

The RM-2000 has a second RS-485 port allowing connection to a network host, such as a PLC, DCS, or SCADA system or a PC running Modbus master software such as SymCom's *Solutions*.

The network host is not required. If present, the network host must be connected to Comm Port 2 at the connections labeled **A2** and **B2**. The RM-2000 can be programmed as device address A01– A99 and up to 99 RM-2000s or 777s can exist on the same network. The RM-2000's slave and master ports can be programmed for 300, 600, 1200, 2400, 9600, 14400, 19200 or 28800 baud. It can use even, odd or no parity and have 1 or 2 stop bits.

THE RS-485 NETWORK

Terminating Resistors

In figure 2 there are three RS-485 networks. Each of the two RM-2000s with their slave Model 777 forms a separate, independent RS-485 network. The third network links the host PC to the two RM-2000s. Each independent network may require terminating resistors and may require a ground connection for the shield around the twisted pair cable.

If the length between the RM-2000 and the Model 777 exceeds 100 feet or if the twisted pair cable is in a noisy environment, 120Ω terminating resistors should be connected at both the RM-2000 (across A1 and B1) and also at the Model 777 (across A and B of the RS485MS-2W module). In addition, the shield of the twisted pair cable should be tied to the RM-2000's ground connection (labeled GND) with a single 100Ω resistor.

Unlike the port-powered RS-232 to RS-485 converter, the transceiver inside the RM-2000 is capable of supplying enough current to operate the RS-485 network, even with terminating resistors installed. If you are unsure if terminating resistors are required, it would be good to use them. The RM-2000 to host is a separate network. It may require separate terminating resistors and ground connection.

Existing Network Installations

If an RM-2000 is being added to a Model 777 in an existing network, the RM-2000's network address must be set to the existing Model 777's address and the Model 777's address must be set to match the overload address of the RM-2000.

The RM-2000 will map the data from the Model 777 into the same register locations as the Model 777, so the RM-2000 will respond just like the Model 777 as far as the Modbus Master software application is concerned. The Modbus Master software will not have to be reprogrammed to communicate with the RM-2000, unless the additional information from the RM-2000 is desired.

OPERATING THE RM-2000

RM-2000 information and functions are divided into five modes:

- REAL TIME
- FAULT HISTORY
- SETPOINT
- SETUP
- CHANGE SETUP (key switch or jumper required)

Press the [MODE] button to switch between these modes. An LED on the left side of the RM-2000 indicates which mode is selected.

Within any mode, the [SCROLL DOWN] and [SCROLL UP] buttons will change the information being displayed.

Only the SETPOINT and SETUP modes allow setting changes. The CHANGE SETUP LED is lit along with the SETPOINT or SETUP LED when a mode setting is ready to be changed. The [CHANGE SETUP DOWN] and the [CHANGE SETUP UP] buttons decrease and increase the value of a setup option. When the desired value is displayed, press [ENTER] to save the setting.

The [RUN/RESET] and [STOP] buttons will energize and de-energize the Model 777's control relay provided the Start/Stop option is enabled in the SETUP mode ("EN.START/STOP: YES"). Set the option to "NO" to disable the [RUN/RESET] and [STOP] buttons.

Note: whether the [RUN/RESET] and [STOP] buttons actually start and stop the motor is dependent on proper motor control connection of the Model 777 and the state of other auxiliary devices in the control circuit.

MODES

REAL TIME: displays all real-time information as well as calculated power factor, power consumption, and total number of starts and trips.

FAULT HISTORY: displays detailed information about the last 4 faults that caused the Model 777 to trip. It also displays the last 10 starts; the length of time the motor has been running; and the date, time and length of the minimum time the motor was off.

SETPOINT: displays the parameters programmed into the Model 777. Examples of these parameters would include the overcurrent and undercurrent limits (OC and UC), the current unbalance (CUB) limit, etc., programmed into the Model 777.

SETUP: displays the parameters that affect the operation of the RM-2000, such as real-time clock settings (month, day, hour, etc.), the network host communications parameters, the voltage multiplier and others.

CHANGE SETUP: allows you to change the parameters that are displayed in the SETUP and SETPOINT modes. **A jumper* connected between K1 and K2 on the back of the RM-2000 is required to enter this mode.** The CHANGE SETUP mode will be skipped when scrolling through the modes if the jumper is not in place.

*Note: If desired, a key-switch can be installed in place of the jumper to allow only authorized personnel to make system/setting changes.

LEDs

Eight LEDs indicate the status of the RM-2000:

- Five red LEDs on the left side indicate the display mode
- The green COMM STATUS LED on the lower right indicates the RM-2000 is communicating with the Model 777.
- The green RUN LED on the upper right indicates the motor is drawing current.
- A solid red FAULT LED indicates the Model 777 has tripped on a fault and is either in manual reset mode or the Model 777 is going through restart delay RD2 or RD3. When a fault occurs, the RM-2000 automatically switches to the FAULT HISTORY mode and displays FAULT 1—the most recent fault. The RM-2000 will not switch to the FAULT HISTORY mode if it is currently in the CHANGE SETUP mode.

A blinking red FAULT LED indicates the Model 777 has a pending fault. If the motor is not running, this may be a condition that is preventing the Model 777 from starting, such as high or low voltage. Look at the pending fault screen in the REAL TIME mode to view the existing fault condition.

TROUBLESHOOTING COMMUNICATION LOSS

If the RM-2000 loses communications with the Model 777, the green COMM STATUS LED will not be lit and the REAL TIME mode screens will contain asterisks. For example, the screen showing 3-phase voltages and the average voltage will look like:

V	a	b	=					*		V	b	c	=					*	
V	a	c	=					*		V	a	v	g	=					*

Things to look for:

- 1) Verify the Model 777 has power on lines L1 and L2.
- 2) Verify the Model 777 is programmed with the correct address.
- 3) Verify the RS-485 cable connects A1 of the RM-2000 to A of the Model RS-485MS-2W module and B1 to B.
- 4) If using an older communications module, Model **RS485MS**, verify that A is shorted to Y and B is shorted to Z.
- 5) Verify continuity of the RS-485 cable with an ohmmeter (**NOTE: test for continuity only when the RS-485 circuit is de-energized!**).

PART II - SCREEN INFORMATION

REAL TIME MODE

The REAL TIME mode displays real-time information as well as calculated power factor and power consumption, and total number of starts and trips. By scrolling through the REAL TIME mode the following screens can be viewed:

Current and Voltage Information - displays line-to-line voltages and phase currents.

I	=			5	.	5	0			5	.	6	5			5	.	3	5	
V	=					2	3	0				2	3	5				2	2	5

Line Currents and Average Current

I a =	5 . 5 0	I b =	5 . 6 5
I c =	5 . 3 5	I a v g =	5 . 5 0

Line-to-Line Voltages and Average Voltage

V a b =	2 3 0	V b c =	2 3 5
V a c =	2 2 5	V a v g =	2 3 0

If potential transformers (PTs) are used with the 777, the voltage multiplier (“VOLTAGE MULT” in the SETUP menu) should be programmed with a voltage multiplier equal to the PT ratio. The voltage displayed on the RM-2000 will be higher than the voltage displayed on the 777, but will be consistent with the actual voltage.

Calculated Current and Voltage Unbalance

C U R R . U N B A L A N C E =	3 %
V O L T . U N B A L A N C E =	2 %

Restart delays RD1, RD2 and RD3

R E S . D E L A Y R D 2 =	0 M
R D 1 = 0 S R D 3 =	0 M

RD1: power-up and rapid-cycle delay
 RD2: restart delay after all faults except undercurrent
 RD3: restart delay after an undercurrent fault

NOTE: This screen displays the time remaining for each restart delay, not the setpoint value programmed into the Model 777.

Ground Fault Current: for a motor, this value would likely represent the current leaking through the insulation of one or more phases.

G R O U N D F A U L T C U R R E N T
0 . 1 0 A M P S

Accumulated Hours and Energy

A C C . H O U R S =	0 . 1
E N E R G Y - K W H =	3 . 0

The Accumulated Hours is the number of hours the Model 777 has detected current flow and the Energy-kWh (or Energy-MWh) is the calculated energy consumed during these hours. The information displayed is updated every minute.

The Accumulated information is stored in memory and will not be lost if the RM-2000 loses power. The values can be reset to zero with the CLEAR HISTORY option in the CHANGE SETUP mode.

Number of Starts and Trips - values can be reset to zero by the CLEAR HISTORY option in the CHANGE SETUP mode.

N	O	.	S	T	A	R	T	S	=											5
N	O	.	T	R	I	P	S	=												2

Average Voltage, Current and Power Factor

V	A	V	=			2	3	0	I	A	V	G	=			5	.	5	0
P	O	W	E	R	F	A	C	T	O	R	=					0	.	9	6

If connected to a Model 601, be sure to set the Model to 601 in the CHANGE SETUP mode. This allows the Frequency information of the Model 601 to be displayed on this screen instead of Average Voltage and Average Current.

Power and KVARs - displays consumed motor power in kW and reactive power in KVARs.

P	O	W	E	R	(K	W)	=							1	.	2	1
K	V	A	R	S	=											0	.	6	4

Input Status Bits - displays the status of the RM-2000 input channels (if available).

I	n	p	u	t	B	i	t	s	=	7	6	5	4	3	2	1	0		
					S	t	a	t	u	s	=	0	0	0	0	0	0	0	0

This screen is only visible if the I/O Screens are set to ON (CHANGE SETUP mode).

Pending Fault Information

					P	E	N	D	I	N	G	F	A	U	L	T				
										N	O	N	E							

The Pending Fault screen will display up to three pending faults the Model 777 has sensed. The RM-2000's FAULT LED will blink anytime a pending fault condition exists. If the Model 777 is in a de-energized state, the pending fault identifies present conditions that will prevent the Model 777 from starting. The RM-2000 uses the following codes to represent the faults:

<u>Fault Code</u>	<u>Fault Description</u>
OC	Overcurrent
I SP	Single-phase current
V SP	Single-phase voltage
CUB	Current unbalance
RP	Reverse phase
UC	Undercurrent
VUB	Voltage unbalance
HV	High voltage
LV	Low voltage
GF	Ground fault

Run Time - length of time between the last motor start and stop.

R	U	N	T	I	M	E	:										1	D	A
2	0		H	R	S		2	8		M	I	N		5	4		S	E	C

Minimum Off Time

Date of Minimum Off Time - date and time of the start following the Minimum Off Time.

D	A	T	E		O	F		M	I	N		O	F		T	I	M	E		
2	0	0	7	/	0	3	/	1	1			1	0	:	2	5	:	5	3	P

Minimum Off Time - the minimum length of time the motor was off.

M	I	N		O	F		T	I	M	E	:									
										1		M	I	N		2		S	E	C

Very short times may signify a motor was not allowed to cool down before restarting indicating a programming error or operator override.

NOTE: The Last Start, Run Time, Date of Minimum Off Time and Minimum Off time screens can be cleared by the CLEAR MIN OFF option in the CHANGE SETUP mode.

SETPOINT MODE

The SETPOINT mode displays the parameters that are programmed into the Model 777. Each setting can be viewed and changed using the RM-2000, without interrupting the Model 777's control relay.

Current Limits – overload and underload limits.

O	V	E	R		C	U	R	R	.	:									1	6	.	0	
U	N	D	E	R		C	U	R	R	.	:									1	0	.	0

Voltage Limits - HV and LV settings.

O	V	E	R		V	O	L	T	.	:												2	7	2	
U	N	D	E	R		V	O	L	T	.	:												2	0	7

Unbalance Limits - CUB and VUB settings.

C	U	R	R	.		U	N	B	A	L	:													7	%	
V	O	L	T	.		U	N	B	A	L	:														5	%

Current Multiplier and Ground Fault Limit - MULT and GF settings.

C	U	R	R	.		M	U	L	T	:															5				
G	R	N	D		F	A	U	L	T	:															1	.	2	0	A

Restart Delays - RD1, RD2, RD3 settings.

R	E	S		D	E	L	A	Y		R	D	2	:													3	0	M		
R	D	1	:							0	S			R	D	3	:											2	0	M

- RD1: rapid-cycle delay
- RD2: restart delay after all faults except undercurrent
- RD3: restart delay after an undercurrent fault

NOTE: This screen shows the setpoint for each restart delay, not the time remaining.

SETUP MODE

The SETUP mode displays parameters that affect the operation of the RM-2000.

Real Time Clock

Clock Date Settings - real-time clock *date* settings.

C	L	O	C	K			Y	E	A	R	:	2	0	0	7		
M	O	N	T	H	:	0	3					D	A	Y	:	1	4

Clock Time Settings - real-time clock *time* settings.

H	O	U	R	:	0	1	P			(A	M	/	P	M)	
M	I	N	U	T	E	:	5	9			S	E	C	:	2	6	

The time can be displayed in 24 hour values by changing (AM/PM) to (24HR).

777 Comm Port (Port 1, A1 & B1)

777 Port Address

O	V	E	R	L	O	A	D		(P	O	R	T		1)	
O	V	R	L	D		A	D	D	R	:				A	0	0	1

The Overload Address must match the address programmed into the 777.

777 Port Communication Parameters

O	V	R	L	O	A	D		B	A	U	D	:	9	6	0	0	
P	A	R	I	T	Y	:	E				S	T	O	P	:	1	

To communicate with the 777, the RM-2000 must be set to 9600 baud, even parity, with one stop bit. The RM-2000 can communicate with an overload using 300, 600, 1200, 2400, 9600, 14400, 19200 or 28800 baud; even, odd or no parity; and 0, 1 or 2 stop bits.

Network Comm Port (Port 2, A2 & B2)

Network Port Address

		N	E	T	W	O	R	K		(P	O	R	T		2)		
		N	E	T	W	O	R	K		A	D	D	R	:		A	0	2	6

The host network allows communication between an RM-2000 and a PC with SymCom's *Solutions* software, or a PLC, DCS, or SCADA system. Up to 99 RM-2000s can exist on this network; thus, the network address can be set from A001–A099.

Network Port Communication Parameters

		N	E	T	W	O	R	K		B	A	U	D	:	9	6	0	0	
		P	A	R	I	T	Y	:	N				S	T	O	P	:	1	

The RM-2000 can communicate on a host network using 300, 600, 1200, 2400, 9600, 14400, 19200 or 28800 baud; even, odd or no parity; and 0, 1 or 2 stop bits.

Network Watchdog

N	e	t	w	o	r	k	W	a	t	c	h	d	o	g			
										D	I	S	A	B	L	E	D

An upstream communication watchdog occurs when no upstream messages are received for 10 seconds. Another watchdog will not occur, and no watchdog actions will be taken again until communication is re-established and then lost again for 10 seconds. The network watchdog can be disabled—meaning there will be no action taken if a network watchdog occurs—or two network watchdog functions can be utilized.

- 1) **Send OFF** – when an upstream communication watchdog occurs, the RM-2000 will send an off command to the overload, de-energizing the 777's output relay.
- 2) **Send RHWD** – when an upstream communication watchdog occurs, the RM-2000 will send a remote host watchdog command to the overload (if available).
- 3) **RLY** – when an upstream communication watchdog occurs, the RM-2000 will turn off it on board relays (if available)

Model and Voltage Multiplier

M	O	D	E	L	:											7	7	7
V	O	L	T	A	G	E	M	U	L	T	:							1

Model Number

The Model Number setting should match the model number of the 777 monitored by the RM-2000.

Voltage Multiplier

Voltage Multiplier should be set to 1 unless the 777 is powered by potential transformers (PTs). This multiplier is used to scale the voltage readings up to the actual line voltages being monitored.

Model 777 Power Factor Correction

M	O	D	E	L		7	7	7	M	V	W	I	T	H			
O	N	L	Y		1	P	.	T	.	?	:					N	O

If the Model 777-MV (Medium Voltage) is installed with only ONE potential transformer (PT), set this function to YES—the RM-2000 will adjust the power factor to correct the Power, kVARs, and Energy Usage values. Be sure to check the Model 777-MV installation instructions to keep the proper relationship between PT and CT connections.

LCD Control and UC Alarm Control

A	U	T	O		L	C	D		D	I	M		:		Y	E	S	
A	L	A	R	M		O	N		U	/	C		:		Y	E	S	

LCD Control

If the Auto LCD Dim option is set to NO, the backlighting of the LCD will remain on all the time. If the option is set to YES, the backlighting will automatically turn off 2 minutes after the last button is pressed.

UC Alarm Control

This setting is commonly used in pumping applications. If a well runs dry, the Model 777 will shut down the motor because of an undercurrent condition. Since this may occur frequently in pumping applications, the undercurrent faults can fill up the last four faults of the RM-2000. If you do not want the fault screen to pop up on the RM-2000 when an undercurrent fault is detected, set this field to "NO". This allows the last four faults to keep track of other, unexpected faults.

Starting with Voltage Errors

I	F		S	T	A	R	T	I	N	G		W	/	V	O	L	T	.
E	R	R	O	R	S	:					S	E	N	D		O	F	F

This setting controls how a [RUN/RESET] button is handled when the Model 777 is trying to start, but voltage errors are present.

If a motor has been shut down and the Model 777 detects a voltage error—overvoltage, undervoltage, reverse phase, or voltage unbalance—the Model 777 will not close its control relay until the voltage fault goes away.

When "If Starting w/ Volt. Errors:" is set to SEND OFF—if the [RUN/RESET] button is pressed while the voltage faults are present—the RM-2000 will send an OFF command instead of a START command. This prevents the Model 777 from starting, even after the voltage fault goes away. The RM-2000 displays a message to report this change for about two seconds. The [RUN/RESET] button must be pressed again after the voltage faults are cleared to make the motor start.

When this setting is "SEND ON" and you push the [RUN/RESET] button, a START command will be sent to the Model 777. When the Model 777 receives a START command, it will restart the control contacts as soon as the voltage fault goes away.

Type of Events to Track

L	O	G		M	T	R		S	T	A	R	T	S	:		Y	E	S	
				M	T	R		S	T	O	P	S		:		Y	E	S	
L	O	G		R	M		P	W	R		O	N		:		N	O		
				R	M		P	W	R		L	O	S	:		N	O		
L	O	G		C	O	M	M		O	N				:		N	O		
				C	O	M	M		L	O	S	S		:		N	O		

The RM-2000 will track up to 10 events with the date and time of each event. Specify YES or NO for each of the events according to your system preferences.

CHANGE SETUP MODE

The CHANGE SETUP* mode allows changes to be made to the SETPOINT and SETUP information. To change SETPOINT parameters, press the MODE button until both SETPOINT and CHANGE SETUP LEDs illuminate. To change SETUP parameters, press the MODE button until SETUP and CHANGE SETUP LEDs illuminate.

In the CHANGE SETUP mode, a ">" and "<" will indicate the selected parameter. Use the [SCROLL UP] and [SCROLL DOWN] buttons to move through the parameters. To change the value of a parameter, press the CHANGE SETUP [UP] and [DOWN] buttons. When a value is changed, an asterisk will appear. To save the displayed value, press [ENTER].

* **Note: K1 and K2 must be shorted.**

RM-2000 SPECIFICATIONS		
Control Voltage	115VAC ±10%, 50/60Hz	
Transient Protection	2500V for 10ms	
Power Consumption	3 Watts (max.)	
Communication	MODEL 777	PC, PLC, etc.
Baud Rate	300-28800	300-28800
Setup	None, Odd, or Even Parity, 1 or 2 Stop Bits	None, Odd, or Even Parity, 1 or 2 Stop Bits
Protocol	Modbus RTU	Modbus RTU
Serial Interface	RS485MS-2W	RS485MS-2W
Available Addresses	A001-A099	A001-A099
Real-Time Clock		
Battery Back-up Life	10 years @ 25°C without external power	
Last Fault Memory	Stores up to 4 faults with time and date stamp, includes voltages and currents at time of trip	
Environment		
Class of Protection	NEMA 3R	
Ambient Operating Temperature	-20° to 70°C	
Ambient Storage Temperature	-30° to 70°C	
Humidity	Up to 85%, non-condensing	
Enclosure		
Dimensions	6.1" L x 6.5" W x 1.1" D	
Weight	1.2 lbs.	
Material	Black polycarbonate	
Display	Liquid crystal with extended temperature range	
Size	2 rows x 20 characters	
Lighting	LED backlight	
Keypad	Eight 0.5" stainless steel dome buttons for tactile feedback	
Mechanical Life	50,000 actuations	
Overlay Material	Polyester	
UV Exposure w/out Degradation	2000 hrs.	
Terminal	Depluggable terminal block	
Torque	3 in.-lbs. max.	