

3-Phase Voltage Monitor

Model 201A



Features:

- Protects 3-phase motors from:
 - Low voltage
 - Single-phase
 - Reverse-phase
 - Voltage unbalance
- Diagnostic LED
- Optional high voltage protection
- UL Listed
- CE compliant
- 8-pin plug in; DIN rail or surface mount
 - Convenient for areas with limited space
- 5-year warranty
- Made in the USA

The 201A is an auto ranging 8-pin, plug-in voltage monitor designed to protect 190-480VAC, 3-phase motors regardless of size. It is used to prevent damage caused by single-phasing, low voltage, phase reversal and voltage unbalance conditions.

The unique microcontroller-based voltage and phase-sensing circuit constantly monitors the voltages to detect harmful power line conditions. When a harmful condition is detected, the unit's output relay is deactivated after a specified fixed trip delay. The output relay reactivates after power line conditions return to an acceptable level and a specified fixed amount of time has elapsed (restart delay). The trip delay prevents rapid or short cycling due to rapidly fluctuating power line conditions.



Specifications

Functional Characteristics	
Adjustments/Settings	
Low Voltage (% of setpoint)	
Trip	90%
Reset	93%
High Voltage (% of setpoint) (201A-9 only)	
Trip	110%
Reset	107%
Voltage Unbalance	
Trip	6%
Reset	4.5%
Trip Delay Times	
High/Low and unbalance voltage	4 seconds
Single-phasing faults	2 seconds
Restart Delay Time	
After a fault or complete power loss	2 seconds
Input Characteristics	
Supply Voltage	190-480VAC
Frequency	50/60 Hz
Output Characteristics	
Output Contact Rating - SPDT	
Pilot Duty	480VA @ 240VAC
General Purpose	10A @ 240VAC
General Characteristics	
Operating Temperature	-40° to 70° C (-40° to 158° F)
Maximum Input Power	5 W
Relative Humidity	10-95%, non-condensing per IEC 68-2-3
Terminal Torque	12 in.-lbs.
Wire Gauge	12-22 AWG Solid or stranded
Standards Passed	
Electrostatic Discharge (ESD)	IEC 61000-4-2, Level 3, 6kV contact, 8kV air
Radio Frequency Immunity (RFI), Radiated	150MHz, 10V/m
Fast Transient Burst	IEC 61000-4-4, Level 3, 3.5 kV input power and controls
Surge Immunity	
IEC	IEC 61000-4-5, Level 3, 4kV line-to-line; Level 4, 4kV line-to-ground
ANSI/IEEE	C62.41 Surge and Ring Wave Compliance to a level of 6kV line-to-line
Hi-potential Test	Meets UL508 (2 x rated V + 1000V for 1 minute)
Safety Marks	
UL listed (OT08 octal socket required)	UL508 (File #E68520)
CE	IEC 60947-6-2
Dimensions	1.750"H x 2.375"W x 4.125"D (with socket)
Weight	9 oz.
Mounting Method	Plugs into OT08 Socket (DIN rail or surface mount)

Enclosure Dimensions

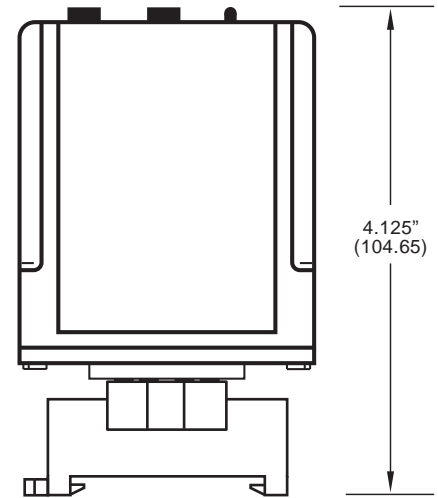

**SIDE
WITH OT08* SOCKET**

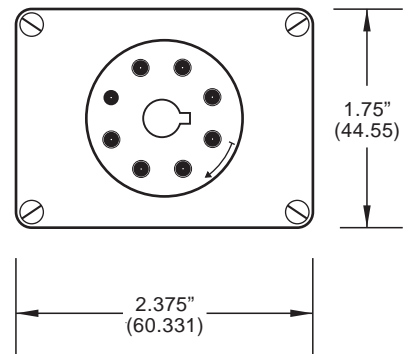

*The OT08 octal socket is 35mm DIN rail compatible. The use of an OT08 octal socket is required to qualify as a UL listed device.

How to order:

Part Number: 201A
201A-9

Auxiliary Products:
OT08-PC (8-pin octal socket)

