





Warnings and Cautions

Warning 	Dangerous Voltage Warning: warns of situations in which a high voltage can cause physical injury and/or equipment damage. The text next to this symbol describes ways to avoid the danger.
Warning 	General Warning: warns of situations that can cause physical injury and/or equipment damage by means other than electrical. The text next to this symbol describes ways to avoid the danger.

General Safety Instructions

Warning 	Be sure to read, understand, and follow all safety instructions.
Warning 	Only qualified electricians should carry out all electrical installation and maintenance work on the V1k drive output filter.
Warning 	All wiring must be in accordance with the National Electrical Code (NEC) and/or any other codes that apply to the installation site.
Warning 	Disconnect all power before working on the equipment. Do not attempt any work on a powered V1k output filter.
Warning 	The V1k, VFD, motor, and other connected equipment must be properly grounded.
Warning 	The VFD terminals and connected cables are at a dangerously high voltage when power is applied to the VFD, regardless of motor operation.

Field Wiring

Field Wiring Connection Terminals

Compression type terminals are provided for all field wiring connections. The wire size capacity ranges and tightening torque for the grounding and power terminals are listed in the table.

V1k Model Numbers	Ground Stud Size	Input and Output Motor Power	
		Wire Size	Torque (in. - lb.)
V1K2A to V1K12A	1/4"	18 - 12 AWG	10
V1K16A to V1K80A	1/4"	18 - 4 AWG	20
V1K110A to V1K130A	3/8"	6 - 2/0 AWG	120
V1K160A	3/8"	6 AWG - 250 MCM	275
V1K200A to V1K250A	3/8"	(2) 14 - 2/0 AWG	120
V1K305A	1/2"	4 AWG - 600 MCM or (2) 1/0 AWG - 250 MCM	500
V1K362A	1/2"	(2) 4 AWG - 350 MCM	275
V1K420A to V1K600A	1/2"	(2) 2 AWG - 600 MCM	500
V1K750A	1/2"	6 AWG - (3) 300 MCM	275

For V1k Products with the Short Circuit Rating Option. Required fusing for SCCR.

V1K Series Device	Withstand Rating	Branch Protective Device
2-45A	5,000A; 600 VAC	Class J fuse rated 225% of FLA
55-160A	10,000A; 600 VAC	Class J fuse rated 225% of FLA
200-305A	18,000A; 600 VAC	Class J fuse rated 450A max
362A	100,000A; 600 VAC	Class L fuse rated 300% of FLA
420-750A	100,000A; 600 VAC	Class L fuse rated 1200A max

See www.transcoil.com for dimensions tables. Please contact TCI Technical Support or your TCI distributor for application information regarding the use of V1k output filters on the output side of the VFD.



Performance and Protection for Drives

V1k Installation Guide

V1k KLC-Series Motor Protection Filter Installation Instructions

Installation Checklist

- Make sure that the installation location will not be exposed to direct sunlight, rain or dripping liquids, corrosive liquids or gases, explosive or combustible gases or dust, excessive airborne dirt and dust, or excessive vibration.
- Select a mounting area that will allow adequate cooling air and maintenance access.
- Make sure that all wiring conforms to the requirements of the National Electric Code (NEC) and/or other applicable electrical codes.
- Connect the V1k Output Filter grounding stud to a dedicated system ground to ensure safety and filter performance. Use a properly sized grounding conductor.
- Wire the output power terminals of the VFD, T1(U), T2(V), & T3(W) to the input terminals of the V1000 filters A1, B1, and C1.
- Wire the output power terminals, of the V1k, A2, B2, & C2 to the motor power connections.
- Make sure the VFD is set for operating modes and ranges that are compatible with the V1k Output Filter.
- Check the entire system thoroughly before energizing and operating any equipment.

When you receive the unit, you should immediately inspect the shipping container and report any damage to the shipping carrier who delivered the unit.

Verify the Application

Make sure the V1k drive output filter is correct for the application. The current ratings of the V1k should be sized to handle the FLA rating of the motor but not to exceed 110% of the drive output current rating. This output filter is best applied matched closely to the load. The V1k drive output filter is not selected by the drive input current rating.

Variable Frequency Drive Settings

Make sure that the variable frequency drive will be set for operation modes and ranges that are compatible with the V1k output filter:

- Maximum output frequency: 60 Hz
- PWM switching frequency best between 2kHz and 4kHz
- Mode of operation: Do not use with DC braking unless the drive application has been confirmed by TCI Technical Support.
- Do not use on overhauling loads without bus voltage control.

Mounting an open panel unit

If you are mounting an open panel unit in your own enclosure, you must provide an enclosure that is adequately sized and ventilated sufficiently to prevent overheating. The filter is designed with an maximum ambient temperature of 40°C (104°F). If the ambient temperature exceeds this value it is the responsibility of the customer to provide auxiliary cooling to reduce the ambient operating temperature around the V1k filter. TCI strongly recommends using auxiliary cooling devices such as cooling fans, heat exchangers, or possibly air conditioning units when required to maintain the proper operating temperature.

The V1k must be mounted vertically on a smooth, solid surface, free from heat, dampness, and condensation. Mounting it vertically is important for natural convection cooling. A metal plate is provided to mount the V1k on a composite surface.

Power Wiring

The conduit and wiring from the output of the variable frequency drive to the motor must be routed to the V1k and then to the motor. TCI recommends a separate dedicated conduit run for each drive/filter/motor run unless properly shielded and segregated wiring procedures are practiced. Parasitic and induced capacitance can greatly reduce the effectiveness of the filter performance. Under no circumstances should you wire both control and power wire in the same conduit unless the wire way is specifically designed for this practice. The line reactor temperature is sensitive to lead wire oversizing. Avoid lead wires more than five times oversized by copper cross sectional area regardless of the material used. Use 75°C copper conductors only or the equivalent, unless the wire connector is marked for Al/Cu, then the use of aluminum

wire is permitted. Use only copper conductor on units rated above 80 amps.

Wiring Cable Entry Locations

TCI has provided enclosure knock-outs on the two smaller enclosures for incoming and outgoing power cables. These are located in a typical wiring location for customer convenience. On the two larger size enclosures, TCI has not provided knock-outs due to the wide variety of application requirements. TCI allows installing electricians the option of locating the cable openings at a point of their choosing.

Grounding

The V1k panel equipment grounding lug must be connected to the ground of the premises wiring system. This can be conducted by identifying a known premises ground near by the filter or running a special ground dedicated for this application. The ground connection must be made using a wire conductor. Metallic conduit is not a suitable grounding conductor. The integrity of all ground connections should be periodically checked.

Wiring Diagram

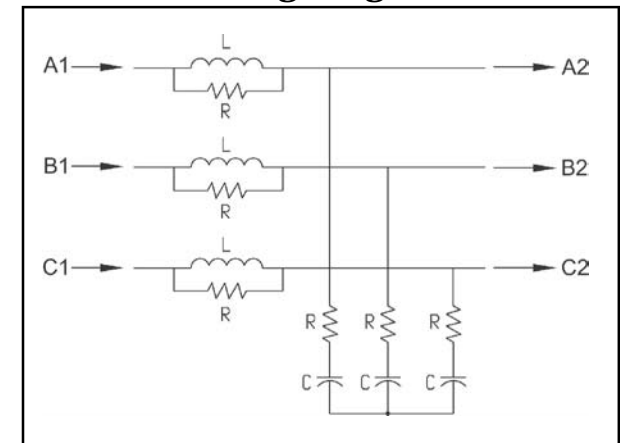

Product Specifications

- u Current Rating: 2 - 750 Amps
- u UL and CUL Listed
- u Open and UL Type 1 Enclosures
- u Efficiency > 98%
- u Insulation Rating: 600V Class
- u Insulation Class: Class H (180°C or Better)
- u Altitude (Maximum): 1000 m
- u Lead Length: 3000 ft (Specific Applications)
- u Operating Temp: 40°C Ambient