



The dual-channel **MS31-LIU** analog data repeater isolates, converts and repeats standard analog signals and passes them to a user-defined output.

The input circuit accepts a standard current input (0/4-20 mA), a standard voltage input (0/2-10 V) or a variable voltage input (0-1 V to 0-10 V).

The transfer characteristics are programmed using jumpers across terminals 14, 15 and 16 (see diagram). This allows dead-zero signals to be converted to live zero and vice versa. The device also converts current signals to voltage signals and vice versa.

The analog output signal is available at both outputs, which may be used simultaneously. One output is a voltage output; the other is a current output.

The power supply is galvanically isolated from the input and output circuits. A green LED provides power "ON" indication.

Special version:

**MS31-LIU.../M12**: signal inverter (0-20 mA inverted to 20-0 mA).

MS31-LIU/24VDC  
MS31-LIU/115VAC  
MS31-LIU/230VAC

### Connection Diagram

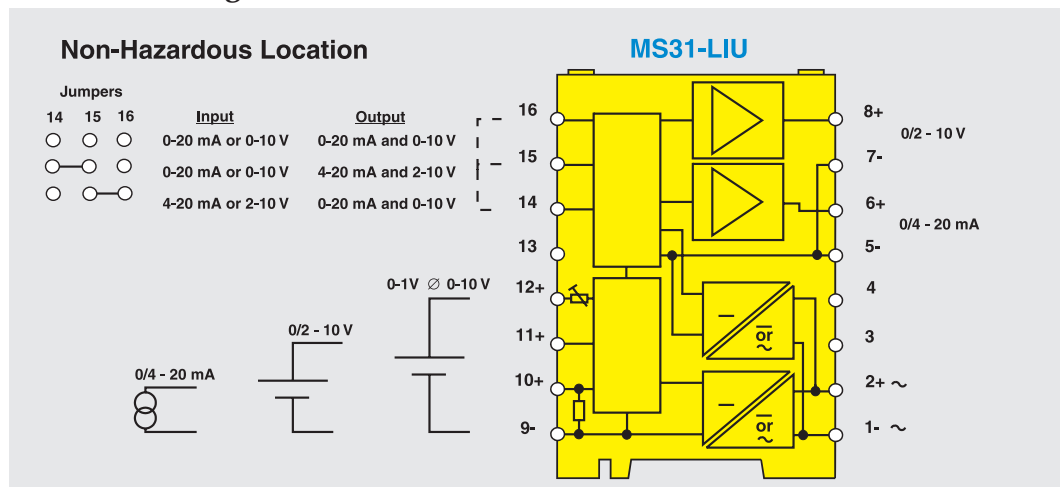

## Analog Signal Repeater/Converter MS31-LIU/...(24VDC/115VAC/230VAC)

Type	MS31-LIU/24VDC	MS31-LIU/115VAC	MS31-LIU/230VAC
ID Number	M0531700	M0531100	M0531000
<b>Power Supply</b>			
Supply voltage	19.2-28.8 VDC, ≤10% ripple	98-126 VAC, 48-62 Hz	184-264 VAC, 48-62 Hz
Power consumption	≤3 W	≤5 VA	≤5 VA
Galvanic isolation	between input circuit, output circuit and supply voltage, test voltage 2.5 kVrms	between input circuit, output circuit and supply voltage, test voltage 2.5 kVrms	between input circuit, output circuit and supply voltage, test voltage 2.5 kVrms
<b>Input Circuits</b>			
Voltage input	0/2-10 V	0/2-10 V	0/2-10 V
- Input resistance	50 kΩ	50 kΩ	50 kΩ
- Operating characteristics	0/2-10 V	0/2-10 V	0/2-10 V
Current input			
- Input resistance	50 Ω	50 Ω	50 Ω
- Operating characteristics	0/4-20 mA	0/4-20 mA	0/4-20 mA
Variable voltage input			
- Input resistance	5 kΩ/V	5 kΩ/V	5 kΩ/V
- Operating characteristics	0-(1-10) V	0-(1-10) V	0-(1-10) V
<b>Output Circuits</b>			
Voltage output	0/2-10 V	0/2-10 V	0/2-10 V
- Load resistance	≥1 kΩ	≥1 kΩ	≥1 kΩ
Current output	0/4-20 mA	0/4-20 mA	0/4-20 mA
- Load impedance	≤500 Ω	≤500 Ω	≤500 Ω
<b>Transfer Characteristics</b>			
Linearity tolerance	≤0.1% of full scale	≤0.1% of full scale	≤0.1% of full scale
Load impedance	≤0.01% of full scale	≤0.01% of full scale	≤0.01% of full scale
Effect of load impedance	≤0.01% of full scale	≤0.01% of full scale	≤0.01% of full scale
Conversion error (V→I; I→V)	≤0.1% of full scale	≤0.1% of full scale	≤0.1% of full scale
Ambient temperature sensitivity	≤0.005% / K of full scale	≤0.005% / K of full scale	≤0.005% / K of full scale
Pulse rise time (10-90%)	<50 ms	<50 ms	<50 ms
Release time (90-10%)	<50 ms	<50 ms	<50 ms
<b>LED Indications</b>			
- Power "ON"	green	green	green
<b>Housing Style</b>	Diagram E (page A18)	Diagram E (page A18)	Diagram E (page A18)

### Programming

Selection of transfer functions

- 1:1 Transfer
- Dead-zero conversion
- Live-zero conversion
- Current/voltage conversion
- Voltage/current conversion

Inputs	Transfer Functions	Outputs	Jumper Terminals
0-20 mA, 0-10 V		0-20 mA, 0-10 V	14 ○ 15 ○ 16 ○
0-20 mA, 0-10 V		4-20 mA, 2-10 V	14 ○—○ 15 ○ 16 ○
4-20 mA, 2-10 V		0-20 mA, 0-10 V	14 ○ 15 ○—○ 16 ○