

TURCK

DC Self-Contained Air Monitors



FCS-GL1/2 A2P-LIX-H1141/A

- Monitor and signal processor in one compact housing
- Analog output, 4 - 20 mA
- Current output indication via six LEDs
- Protection class IP 67
- Simple adjustment by means of potentiometer

The FCS-GL1/2A2P-LIX flow monitors are self-contained devices. Monitor and signal processor are incorporated in one compact housing. They monitor nonexplosive gaseous media in a flow speed range from 0.5 to 30 m/s.

The flow monitors are designed to be installed directly into the flow stream by means of a GL1/2 thread with the sensing probe protruding into the flow. The probes are made of 303 stainless steel.

The monitors must be mounted at a specific orientation with respect to flow (see diagram on page 12). They feature a 4 - 20 mA current output. A potentiometer serves for adjusting the sensor to the flow range. 20 mA should correspond to the maximum flow rate.

The output curve indicates the typical correlation between the output signal and flow rate.

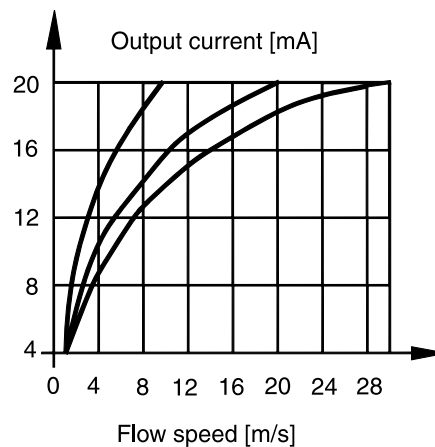

Flow Monitors for Air and Gaseous Media Analog Output FCS-GL1/2 A2P-LiX-H1141/A

Type	FCS-GL1/2A2P-LiX-H1141/A
ID Number	M6870455
Output	current output
Load	≤500 Ω
Output current	4 - 20 mA
Linearity deviation	≤10%
Temperature Range (flow)	-20° to +80°C (-4° to +176°F) continuous
Operating Range (flow rate)	
Air	0.5 - 30 m/s (98.5 - 5906 ft/min)
Availability	20 - 90 s
Response time to changes in flow rate	4 - 30 s
Response time to changes in temperature	≤100 s
Temperature gradient	max. 20 K/min.
Pressure Rating	435 psi (30 bar)
LED Indications	
Output status	5 green , 1 red
1 to 6 illuminate:	
- LED 6	≥20 mA
- LED 5	>16 mA
- LED 4	>12 mA
- LED 3	> 8 mA
- LED 2	> 4 mA
- LED 1 (red)	= 4 mA
Sensor Housing Material	303 stainless steel (1.4305)
Enclosure (DIN 40 050)	IP 67, NEMA 1,3,4,4x,12,13
Operating temperature	-20° to +80°C (-4° to +176°F)
Housing Material (DIN 2 462)	PBT
Enclosure (DIN 40 050)	IP 67, NEMA 1,3,4,4X,12,13)
Operating temperature	-20° to +70°C (-4° to +158°F)
Connection	3-wire euromast [®] quick disconnects RK 4T-* or WK 4T-* (See page 65) * = length in meters
Accessories	1 screwdriver for span adjustment

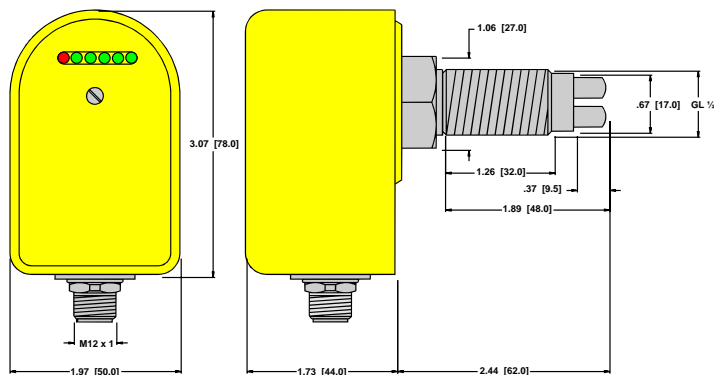

FCS-GL1/2A2P-LiX-H1141/A

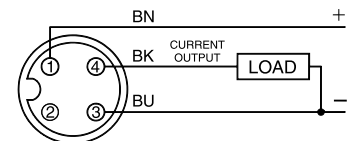

Mounting Position

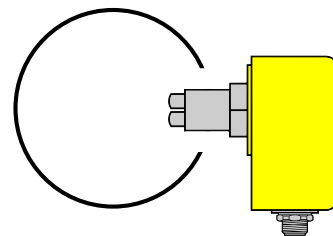

Note: G threading refers to British parallel pipe (BSPP) threading.

TURCK

DC Self-Contained Air Monitors



FCS-K20-AP8X FCS-M18-AP8X

- **Monitor and signal processor in one compact housing**
- **Protection class IP 67**
- **Maximum switch point accuracy during changes in flow temperature**
- **Simple adjustment by means of potentiometer**
- **Transistor output, PNP, short-circuit protected**

The FCS-K20-AP8X flow monitors are self-contained devices. Monitor and signal processor are incorporated in one compact housing. They monitor nonexplosive gaseous media in a flow speed range from 0.5 to 15 m/s.

The flow monitors are designed to be installed directly into the flow stream, by means of a plastic flange coupling or lock washers, with the sensing probe protruding in the flow. As a result, the flow monitors are suitable for use in various pipe diameters or ductwork.

These flow monitors feature a short-circuit protected PNP transistor output. A potentiometer serves for setpoint adjustments in reference to the flow speed.

One two-color LED indicated the flow status in reference to the preset set point:

Red LED: flow below setpoint
Green LED: flow at or above set point

When the red LED illuminates, the output is de-energized. The yellow LED is on when the output is energized.

Flow Monitors for Air and Gaseous Media Discrete Output FCS-K20-AP8X FCS-M18-AP8X

Type	FCS-K20-AP8X	FCS-M18-AP8X
ID Number	M6870792	M6870704
Operating Voltage	19.2 - 28.8 VDC (including ripple)	19.2 - 28.8 VDC (including ripple)
Current consumption	≤70 mA	≤70 mA
Temperature Range (flow)	-20° to +70°C (-4° to +158°F) continuous	-20° to +70°C (-4° to +158°F) continuous
Operating Range (flow rate)		
Air	0.5-15 m/s (98.5-2952 ft/min)	0.5-15 m/s (98.5-2952 ft/min)
Repeatability	±5% of full range	±5% of full range
Time Delay Before Availability	20-40 s (25 s typical)	20-40 s (25 s typical)
Response Time	1-4 s (6 s typical)	1-4 s (6 s typical)
Pressure Rating	14.5 psi (1 bar)	145.0 psi (10 bar)
Housing Material (DIN 2 462)	PBT-GF30-V0	Chrome Plated Brass
Enclosure (DIN 40 050)	IP 67, NEMA 1,3,4,12,13	IP 67, NEMA 1,3,4,12,13
Operating temperature	-30° to +60°C (-22° to +140°F) continuous	0° to +60°C (32° to +140°F) continuous
Connection	PVC cable, 3-wire 2 m standard length (21 AWG)	PVC cable, 3-wire 2 m standard length (21 AWG)

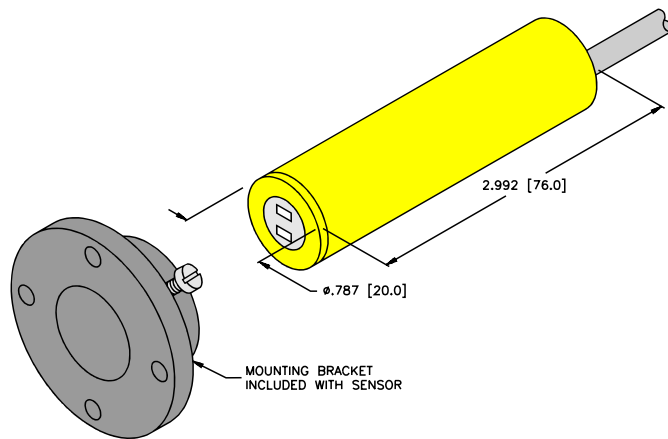

FCS-K20-AP8X

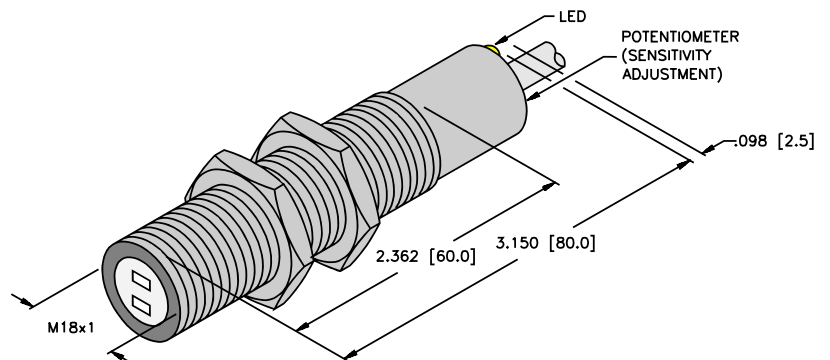
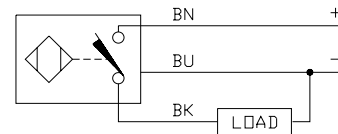

FCS-M18-AP8X

TURCK

DC Self-Contained Air Monitors



FCS-K20-LIX FCS-M18-LIX

- Monitor and signal processor in one compact housing
- Analog output, 4-20 mA
- Protection class IP 67
- Maximum switch point accuracy during changes in flow temperature
- Simple adjustment by means of potentiometer

The FCS-K20-LiX flow monitors are self-contained devices. Monitor and signal processor are incorporated in one compact housing. They monitor nonexplosive gaseous media in a flow speed range from 0.5 to 15 m/s.

The flow monitors are designed to be installed directly into the flow stream, by means of a plastic flange coupling or lock washers, with the sensing probe protruding in the flow. As a result, the flow monitors are suitable for use in various pipe diameters or ductwork.

These flow monitors feature a 4-20 mA analog output. A potentiometer serves for adjusting the sensor to the flow range. 20 mA should correspond to the maximum flow rate. The factory setting of the output signal is 20 mA at a flow speed of 15 m/s (air).

Operational readiness (power on) is indicated by a green LED.

The curve shows the typical correlation between the output signal and flow speed.

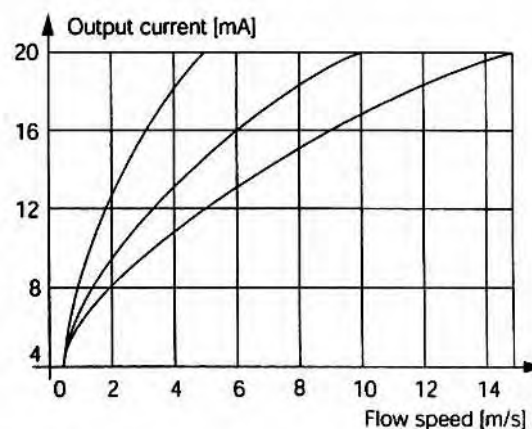

Flow Monitors for Air and Gaseous Media Linear Analog Output FCS-K20-LIX FCS-M18-LIX

Type	FCS-K20-LIX	FCS-M18-LIX
ID Number	M6870791	M6870707
Operating Voltage	19.2-28.8 VDC (including ripple)	19.2-28.8 VDC (including ripple)
Current consumption	≤70 mA	≤70 mA
Output	4 - 20 mA current output	4 - 20 mA current output
Load	200-500 Ω	200-500 Ω
Linearity deviation	≤10%	≤10%
Temperature Range (flow)	-20° to +70°C (-4° to +158°F) continuous	-20° to +70°C (-4° to +158°F) continuous
Operating Range (flow rate)		
Air	0.5-15 m/s (1.6-49.2 ft/s)	0.5-15 m/s (1.6-49.2 ft/s)
Time Delay Before Availability	20-40 s (25 s typical)	20-40 s (25 s typical)
Response Time	1-20 s (6 s typical)	1-20 s (6 s typical)
LED Indication		
Power on	green	green
Pressure Rating	14.5 psi (1 bar)	145.0 psi (1 bar)
Housing Material (DIN 2 462)	PBT-GF30-V0	Chrome Plated Brass
Enclosure (DIN 40 050)	IP 67, NEMA 1,3,4,12,13	IP 67, NEMA 1,3,4,12,13
Operating temperature	-30° to +50°C (-22° to +122°F) continuous	0° to +60°C (+32° to +140°F) cont.
Connection	PVC cable, 3-wire 2 m standard length (21 AWG)	PVC cable, 3-wire 2 m standard length (21 AWG)

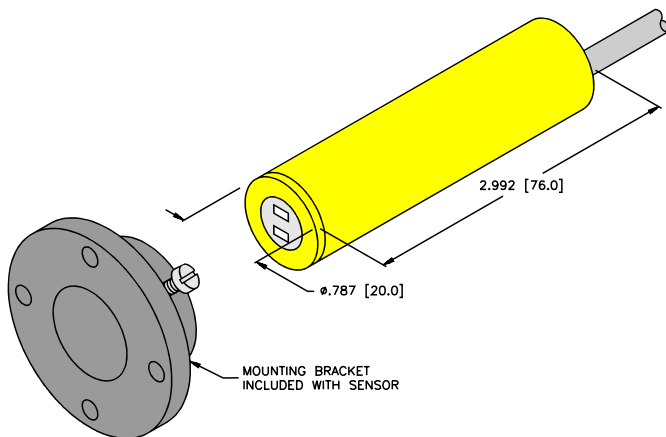

FCS-K20-LiX

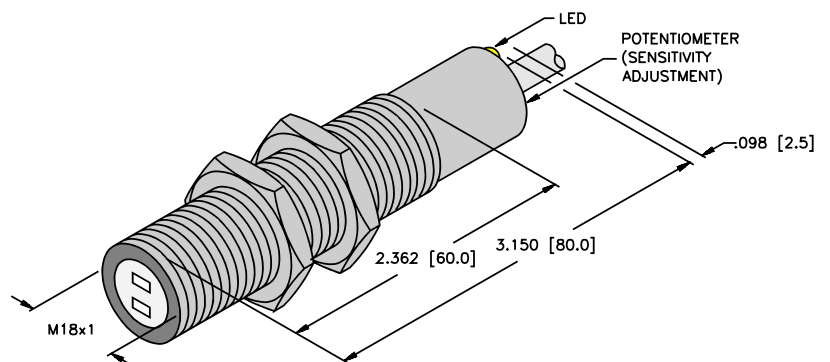
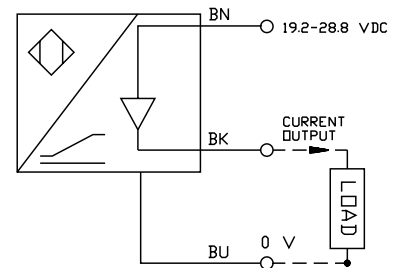

FCS-M18-AP8X