

# TURCK

## Network Media Products

The DPC-System (Diagnostic Power Conditioner System) is a power supply system for the installation of FOUNDATION™ fieldbus H1 segments. It provides comprehensive diagnostic functions for the monitoring of FOUNDATION fieldbus segments and supports asset management for the entire system.

A DPC system consists of one or more module racks (DPC-49-MB-RC) each with up to eight power supply modules (DPC-49-IPS) and one diagnostic module (DPC-49-ADU). Up to four H1 segments for each module rack can be operated and monitored redundantly. The diagnostic data from the H1 segments are transmitted via the HSE interface module (DPC-49-HSEFD/24VDC) to the higher level asset management system.

The diagnostic module (DPC-49-ADU) is used as a communication and diagnostic interface between the H1 segments and the power supply module. The diagnostics module monitors the electrical parameters and the communication parameters of the H1 segments. Operation without diagnostic module is possible. In this configuration, simple diagnostics are provided locally.

The diagnostic information is collected in the device and transmitted via the HSE interface module to the higher fieldbus level (e.g. to the host) as diagnostic and alarm data. The diagnostic module can be plugged in and unplugged during operation (hot swappable).

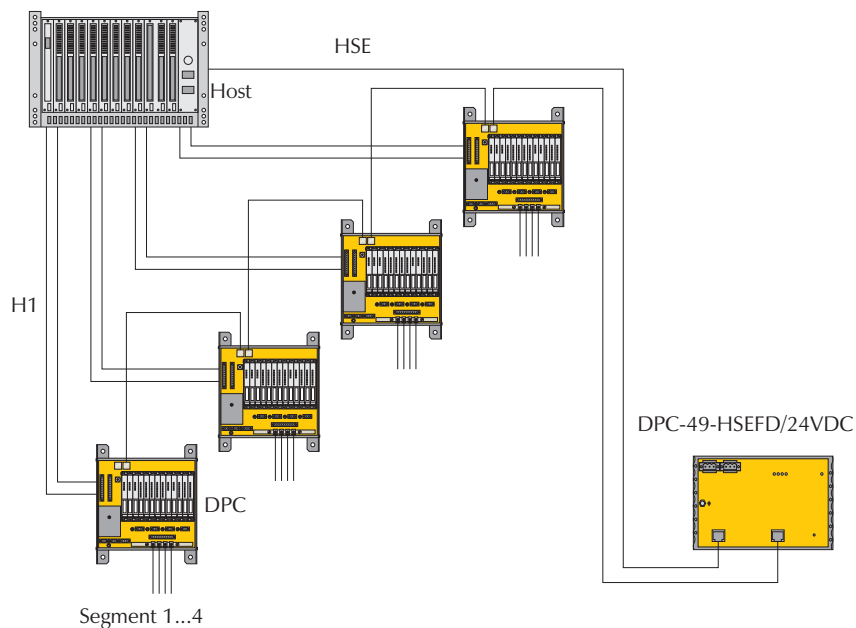
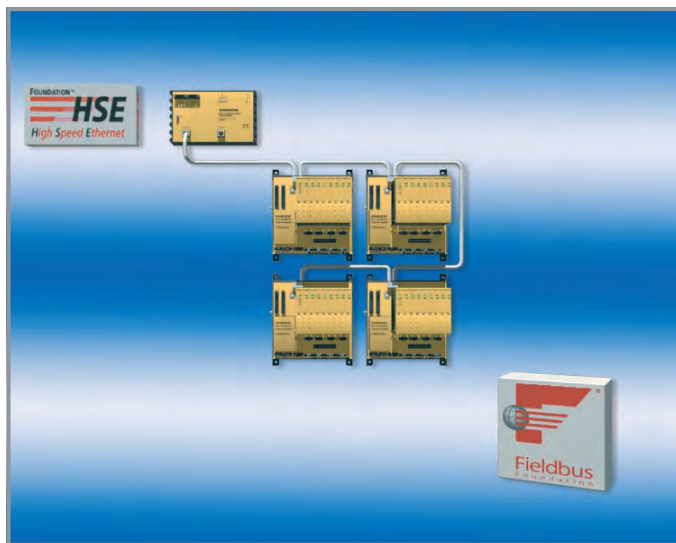

**DPC system configuration**



**Diagnostics via DTM**

## Fieldbus - The dynamic asset

Information concerning the components of the control system and field devices are typically stored and monitored by that system. Information on assets that make up the communication infrastructure (physical layer components) have been simply stored in an asset management system. With the DPC system, the physical layer components are continuously monitored providing virtually instantaneous information regarding the quality and the status of the communication link.

This aspect of the system is the key to achieving the main objective of asset management to minimize maintenance and lower system operating costs.

**TURCK** has drastically improved on existing physical layer components for use in FOUNDATION™ fieldbus applications. The introduction of this system allows the continuous monitoring of every physical layer component, thus treating the entire physical layer as an asset and providing the means for it to be managed as such.

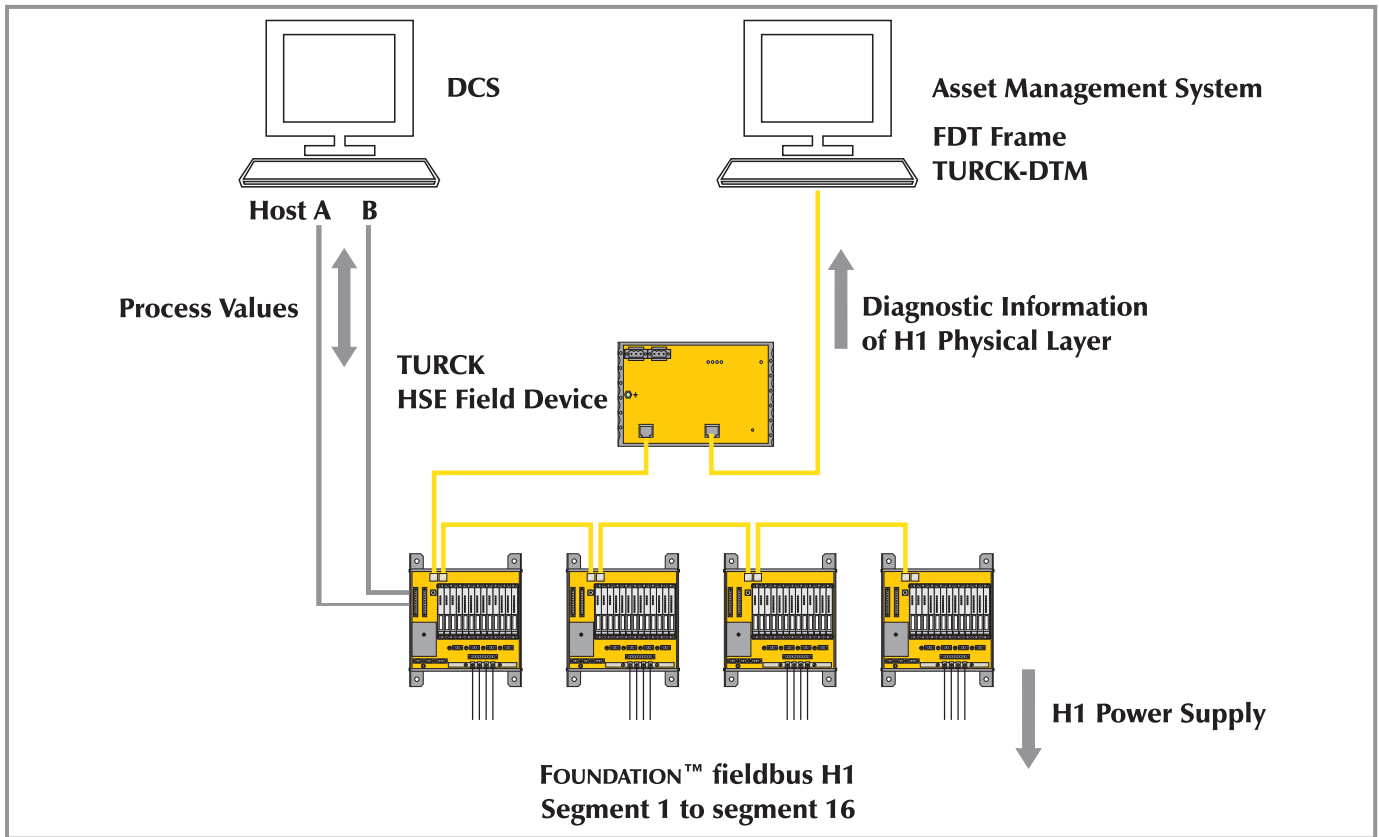

The DPC System detects errors that may develop over an extended period of time or through typical failure modes. These changes can occur due to many factors, such as environmental changes, deterioration of components over time, and any other factors that may affect the physical components of a fieldbus segment. Some of these factors may appear as changes in jitter, hum, noise levels etc. Alarm strategies may be employed that will warn of typical asset errors, potential errors or failures. Preventive measures can be implemented well in advance of a potential system failure. Most common failures can be completely avoided when a preventive maintenance schedule is implemented. The DPC system also supports the set-up of fieldbus assets by using expedient localization of error sources, as well as documentation indicating a "good condition" of the segment structure.

The DPC system provides an option for redundant segment supplies. The system, fully loaded, can accommodate up to 16 fully redundant FOUNDATION fieldbus segments each with an output of 800 mA and 30 VDC. Diagnostic data is available via a DTM, standard FOUNDATION fieldbus function block libraries or an embedded web server in the HSE field device.

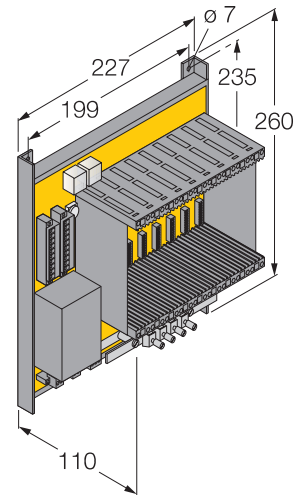

The DPC-System (Diagnostic-Power-Conditioner-System) is a power supply system for the installation of FOUNDATION™ fieldbus H1 segments. It offers comprehensive diagnostic functions for the monitoring of FOUNDATION™ fieldbus segments and thus supporting Asset Management for the whole system.

A DPC system consists of one or more module racks DPC-49-MB-RC each with up to eight power supply modules DPC-49-IPS and one diagnostic module DPC-49-ADU. Up to four H1 segments for each module rack can be operated and monitored redundantly in the FOUNDATION™ fieldbus. The diagnostic data from the H1 segments are transmitted via the HSE interface module DPC-49-HSEFD/24VDC to the higher level Asset-Management-System.

The module rack DPC-49-MB-RC consists of a backplane and the actual rack system for the power supply modules and the diagnostic module.

The single components of the system are electrically linked via the connection terminals of the backplane from the user side. Thereby from an electrical perspective, the backplane is to be considered passive.

The power can be supplied via two 2-pole screw connectors. The connection to the host system is established via two system cables. Optional Pre-assembled system cables are available at **TURCK**.

For the connection of the H1 segments to the fieldbus side a 2-pole screw connector terminal is provided for each segment, or alternatively a 10-pole screw connector terminal for all segments together on the system side (system connection). Each H1 segment is equipped with a terminating resistor.

Shielding is established via a shielding bus bar DPC-49-SB4 or via the system connection, which is internally connected with the M5 threaded bolt for equipotential bonding.

A connection to the relay alarm contact of the diagnostic module is available for simple diagnostics processing. Additionally a terminal for the connection of test devices is available for each H1 segment.

The rack system is made of extruded aluminum sections. Thus high system stability and shielding is guaranteed. The module rack is suited for wall mounting as well as for 19" rail mounting.

#### Features:

- Backplane for up to 8 power conditioner modules and 1 diagnostics module
- Exchangeable EMC filter
- Redundant host connection
- Redundant power supply
- Removable terminal blocks with screw connection
- RJ45 connector for HSE fieldbus diagnostics
- Insulated shield terminals
- Terminating resistor with segment output

**Backplane for the DPC System**

**DPC-49-MB-RC**

<b>Part Number</b>	DPC-49-MB-RC
ID Number	M6882010
<b>Fieldbus Standard</b>	IEC 61158-2
<b>Operating Voltage (Pwr)</b>	18 to 32 VDC
Surge / Overvoltage Suppression	< 250 mA
<b>Connection</b>	Removable terminal block, reverse polarity protected, screw connection RJ45 socket
<b>Protection Degree</b>	IP 20
Ambient Temperature	-20 to +60°C (-4 to +140°F)
Housing Material	Aluminum
Housing Color	Black / Yellow
Dimensions	227 x 260 x 110 mm
Mounting	Flush Panel

**Installation Example:**

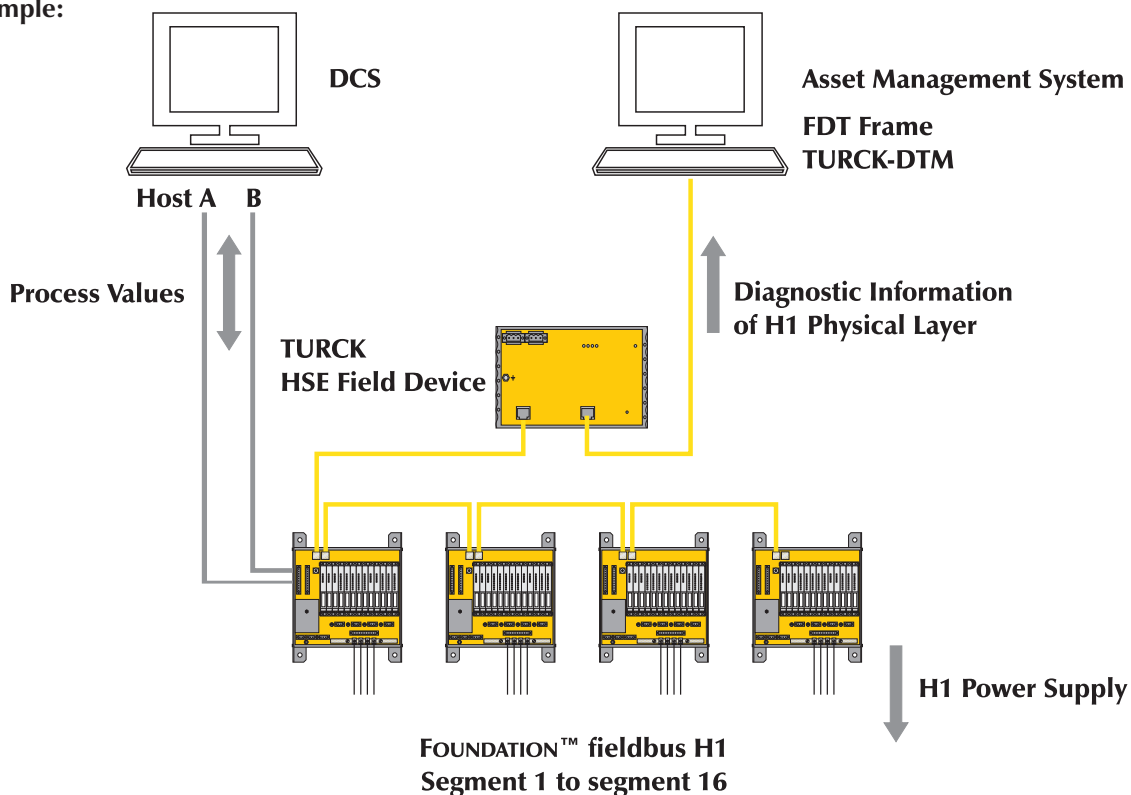

FOUNDATION fieldbus

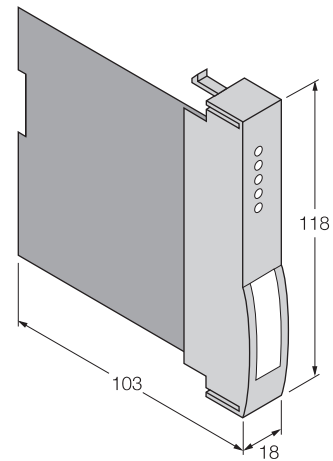

The DPC-System (Diagnostic-Power-Conditioner-System) is a power supply system for the installation of FOUNDATION™ H1 segments. It offers comprehensive diagnostic functions for the monitoring of FOUNDATION™ fieldbus segments and thus supporting Asset Management for the whole system.

A DPC system consists of one or more module racks DPC-49-MB-RC each with up to eight power supply modules DPC-49-IPS and one diagnostic module DPC-49-ADU. Up to four H1 segments for each module rack can be operated and monitored redundantly in the FOUNDATION™ fieldbus. The diagnostic data from the H1 segments are transmitted via the HSE interface module DPC-49-HSEFD/24VDC to the higher level Asset-Management-System.

The power supply module provides up to 30 VDC and 800 mA for the installation of the segment. Due to this maximum output power broad segment allocation (up to 1900 m) is possible without restriction.

If two power supply modules are applied, a redundant operation of the segment is possible. Therefore the power supply modules can be plugged in and unplugged shock-free (Hot swappable in run).

Due to complete galvanic isolation:

- H1 to H1
- H1 for the internal supply
- H1 to the diagnostics module
- H1 to the HSE diagnostics bus

Potential transfer is avoided and an error-free communication is insured. In order to simplify the start-up and the diagnostics on site, the following LED functions are available:

- Pwr: green: Operational readiness
- On / Off yellow: Output switched on
- Load: yellow: Recognition of consumers (field device) at the segment
- Com: yellow: Communication display
- Fault: red: Short-circuit message

## Features:

- Supply of a FOUNDATION™ fieldbus H1 segment
- Output current: 800 mA
- Output voltage: 28 to 30 VDC
- Local diagnostics via LEDs
- Complete galvanic isolation

**Power Supply Module**

**DPC-49-IPS**

<b>Part Number</b>	DPC-49-IPS
ID Number	M6882013
<b>Fieldbus Standard</b>	IEC 61158-2
<b>Supply Voltage</b>	Via the backplane
Current Consumption	0.8 to 1.7 A
Galvanic Isolation	Complete galvanic isolation, test voltage 500 VAC
<b>Output Circuits</b>	Field
Output Current	≤ 800 mA
Output Voltage	> 28 VDC
Short-circuit Protection	≤ 850 mA
Efficiency	80%
Output Circuits	HOST
Output Current	< 30 mA
Output Voltage	< 27 VDC
<b>Indication</b>	
Operational Readiness	1 x green
Output Active	1 x yellow
Output Current	1 x yellow
Short-circuit Message	1 x red
Bus Communication	1 x yellow
<b>Protection Degree</b>	IP 20
Ambient Temperature	-20 to +60°C (-4 to +140°F)
Housing Material	Plastic / flammability class V-0 to UL 96
Housing Color	Yellow
Dimensions	18 x 118 x 103 mm

**Installation Example:**

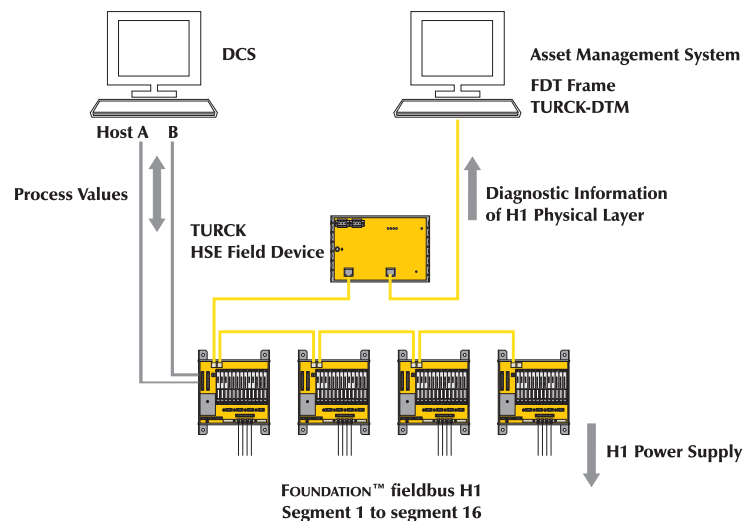

FOUNDATION fieldbus

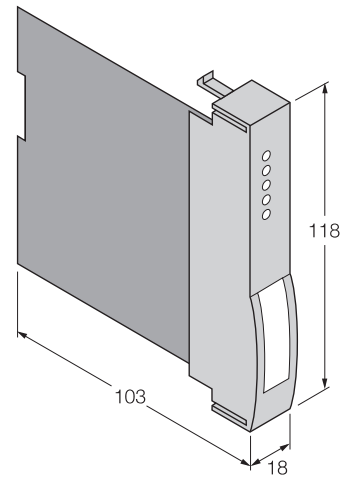

The DPC-System (Diagnostic-Power-Conditioner-System) is a power supply system for the installation of FOUNDATION fieldbus™ H1 segments. It offers comprehensive diagnostic functions for the monitoring of FOUNDATION fieldbus™ segments and thus supporting Asset Management for the whole system.

A DPC system consists of one or more module racks DPC-49-MB-RC each with up to eight power supply modules DPC-49-IPS and one diagnostic module DPC-49-ADU. Up to four H1 segments for each module rack can be operated and monitored redundantly in the FOUNDATION fieldbus™. The diagnostic data from the H1 segments are transmitted via the HSE interface module DPC-49-HSEFD/24VDC to the higher level Asset-Management-System.

The diagnostic module DPC-49-ADU is used as a communication and diagnostic interface between the H1 segments and the power supply module. The diagnostics module monitors the electrical parameters and the communication parameters of the H1 segments. Operation without diagnostic module is possible.

The diagnostic information is collected in the device and transmitted via the HSE interface module to the higher fieldbus level (e.g. to the host) as diagnostic and alarm data. The diagnostic module can be plugged in and unplugged during operation (Hot swap-able in run).

The device features a LED display which indicates the operating status of the H1 segments. A pre-alarm is indicated yellow and a main alarm red on the LED display. Alarm signals can also be transmitted via a relay contact.

#### **Features:**

- Continuous diagnostics for 4 H1 segments
- Local diagnostics via LEDs
- Alarm signal via relay contact
- Complete galvanic isolation

**Diagnostics Module**

**DPC-49-ADU**

<b>Part Number</b>	DPC-49-ADU
ID Number	M6882012
<b>Fieldbus Standard</b>	IEC 61158-2
<b>Supply Voltage</b>	Via the backplane
Current Consumption	< 100 mA
Galvanic Isolation	Complete galvanic isolation, test voltage 500 VAC
<b>Diagnosis</b>	1 x relay
Switching Current	≤ 1000 mA
Switching Voltage	≤ 30 VDC galvanically isolated against other electronic parts
<b>Operational Readiness</b>	1 x green / red
Alarm	4 x yellow / red
<b>Protection Degree</b>	IP 20
Ambient Temperature	-20 to +60°C (-4 to +140°F)
Housing Material	Plastic
Housing Color	Yellow
Dimensions	18 x 118 x 103 mm

**Installation Example:**

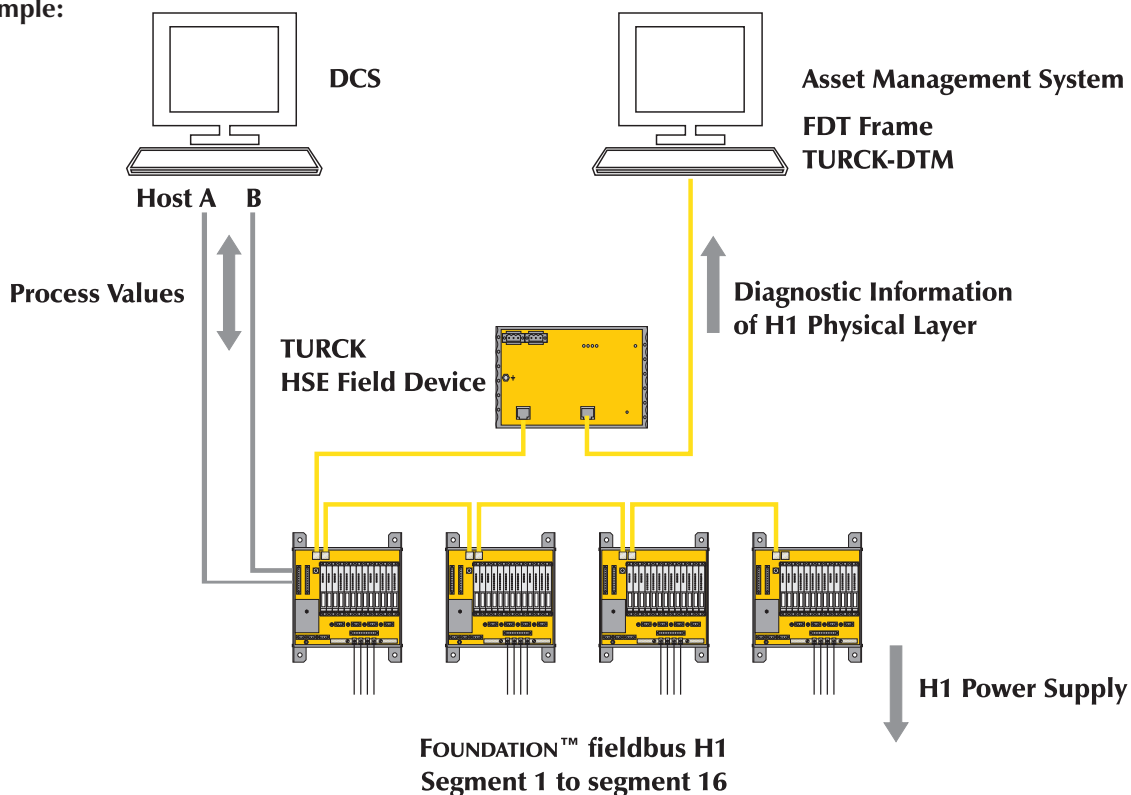

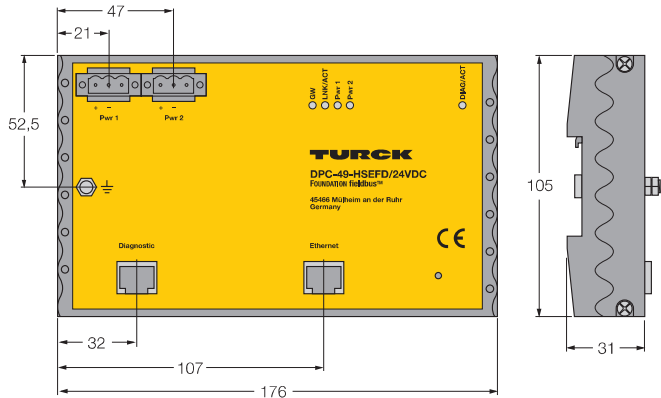

The DPC-System (Diagnostic-Power-Conditioner-System) is a power supply system for the installation of Foundation fieldbus™ H1 segments. It offers comprehensive diagnostic functions for the monitoring of FOUNDATION™ fieldbus segments thus supporting Asset Management for the whole system.

A DPC system consists of one or more module racks DPC-49-MB-RC, each with up to eight power supply modules DPC-49-IPS and one diagnostic module DPC-49-ADU. Up to four H1 segments for each module rack can be operated and monitored redundantly in the FOUNDATION™ fieldbus.

The diagnostic data from the H1 segments are transmitted via the HSE interface module DPC-49-HSEFD/24VDC to the higher level Asset-Management-System. Only the diagnostics data of the diagnostic module DPC-49-ADU are transmitted with the HSE interface module, not the process data of the H1 field device. Each diagnostic module monitors up to four H1 segments.

The HSE interface module is a FOUNDATION™ fieldbus field device, which contains one resource and one transducer block and various standard function blocks. On the basis of these standard function blocks, suitable applications for the analysis of the diagnostics data can be programmed in the control system.

#### Features:

- HSE interface module for the transmission of diagnostic data
- FOUNDATION™ fieldbus function blocks for remote diagnostics
- Diagnostics via LEDs
- Continuous diagnostics for sixteen H1 segments
- Complete galvanic isolation
- Complete galvanic isolation

**HSE Field Device**

**DPC-49-HSEFD/24VDC**

<b>Part Number</b>	DPC-49-HSEFD/24VDC
ID Number	M6882014
<b>Fieldbus Standard</b>	IEC 61158-2
<b>Supply Voltage</b>	Two power terminals - PWR1 & PWR2
Current Consumption	< 100 mA
Galvanic Isolation	Complete galvanic isolation, test voltage 500 VAC
<b>Indication</b>	
Operational Readiness	2 x green
State / Fault	1 x yellow / red
Bus Communication	1 x green / yellow
Int. Communication (CAN)	1 x yellow / red
<b>Protection Degree</b>	IP 20
Ambient Temperature	-20 to +60°C (-4 to +140°F)
Housing Material	Aluminum
Housing Color	Black / Yellow
Dimensions	176 x 105 x 31 mm
Connection Mode	Snap-on DIN rail (DIN 50022)

**Installation Example:**

