

# TURCK

## DC Self-Contained Flow Monitors



### FCS-N1/2 A4-AP8X-H1141 FCS-G1/2 A4-AP8X-H1141

- All stainless steel housing
- DC PNP/NPN transistor output, short-circuit protected
- Flow monitor and signal processor in one compact housing
- Dynamic pressure resistance up to 870 psi
- Simple adjustment by means of potentiometer

This DC self-contained flow device has a flow monitor and signal processor incorporated into one compact housing. It is ideal for monitoring liquid flow speeds in the 2 to 295 ft/min range.

The flow monitor is designed for installation directly into the pipeline by means of a pipe-tee or welded pipe socket. It is suitable for use in a 1/2 inch pipe diameter or larger.

The flow monitor housing is made of 316TI stainless steel, and is rated for dynamic pressures up to 870 psi. The output features a short-circuit protected PNP transistor.

Setpoint adjustments, in reference to flow speed, are achieved by means of an adjuster located under the protective screw cap on the front of the device.

The output is de-energized when the flow speed is below the setpoint; the output is energized when flow speed is above the setpoint. Six LEDs display the flow speed in comparison to the flow speed that the setpoint is adjusted to. The LEDs operate as follows:

Red LED: flow is below setpoint

Yellow LED: flow is at or above setpoint

Green LEDs: each LED indicates a percentage of flow above the setpoint

Notes: Also available in PVDF (Dyflor) housing material.  
Available with NPN transistor output or relay output.  
Consult factory.

## Flow Monitors DC Self Contained FCS-N1/2 A4-AP8X-H1141 FCS-G1/2 A4-AP8X-H1141

<b>Type</b> ID Number	FCS-N1/2 A4-AP8X-H1141 M6871004	FCS-G1/2 A4-AP8X-H1141 M6870004
<b>Operating Voltage</b> Power / Current consumption	19.2 - 28.8 VDC (including ripple) ≤70 mA	19.2 - 28.8 VDC (including ripple) ≤70 mA
<b>Output</b> Switching current Voltage drop	PNP transistor, short-circuit and reverse polarity protected ≤400 mA ≤1.5 V at 400 mA	PNP transistor, short-circuit and reverse polarity protected ≤400 mA ≤1.5 V at 400 mA
<b>Temperature Range</b> (fluid)	-25° to +80°C (-13° to +176°F) cont. up to 100°C (212°F) for approx. 10 min.	-25° to +80°C (-13° to +176°F) cont. up to 100°C (212°F) for approx. 10 min.
<b>Operating Range</b> (flow rate) Water Oil Repeatability	1-150 cm/s (2-295 ft/min) 3-300 cm/s (6-590 ft/min) ±5% of full range	1-150 cm/s (2-295 ft/min) 3-300 cm/s (6-590 ft/min) ±5% of full range
<b>Time Delay Before Availability</b> Switch ON time (above setpoint) Switch OFF time (below setpoint) Temperature gradient	2-15 s (8 s typical) 1-13 s (2 s typical) 1-15 s (2 s typical) max. 250°C/min. (450°F/min.)	2-15 s (8 s typical) 1-13 s (2 s typical) 1-15 s (2 s typical) max. 250°C/min. (450°F/min.)
<b>Pressure Rating</b>	1450 psi (100 bar)	1450 psi (100 bar)
<b>LED Indications</b> Below setpoint, output de-energized At setpoint, output energized Above setpoint, output energized	red yellow green (4)	red yellow green (4)
<b>Housing Material</b> (DIN 2 462/17 440) Enclosure (DIN 40 050) Operating temperature (ambient) Torque	316TI stainless steel (1.4571) IP 67, NEMA 1,3,4,4x,12,13 -25° to +80°C (-13° to +176°F) 100 Nm (73.7 ft-lb)	316TI stainless steel (1.4571) IP 67, NEMA 1,3,4,4x,12,13 -25° to +80°C (-13° to +176°F) 100 Nm (73.7 ft-lb)

### Connection

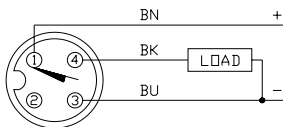

3-wire **eurofast** quick disconnect  
150 m max. cable length (22 AWG)  
RK 4T-\* or WK 4T-\* (Page 65)  
\* = length in meters

3-wire **eurofast** quick disconnect  
150 m max. cable length (22 AWG)  
RK 4T-\* or WK 4T-\* (Page 65)  
\* = length in meters

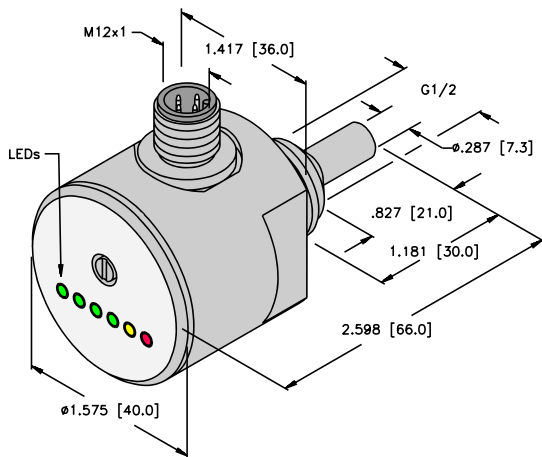

FCS-G1/2 A4-AP8X-H1141

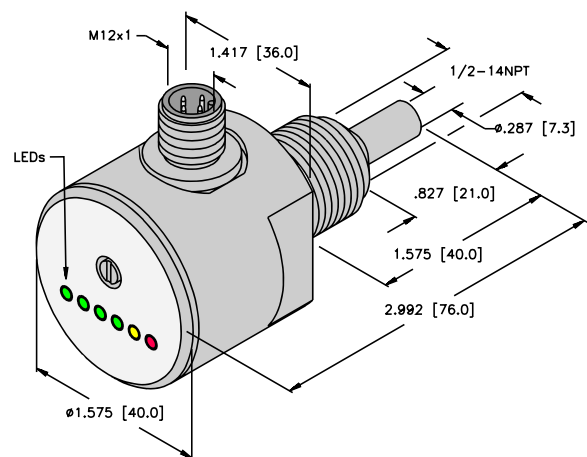

FCS-N1/2 A4-AP8X-H1141

# TURCK

## DC Self-Contained Flow Monitors



### FCS-N1/2 A4P-AP8X-H1141

- DC PNP/NPN transistor output, short-circuit protected
- Flow monitor and signal processor in one compact housing
- Dynamic pressure resistance up to 870 psi
- Simple adjustment by means of potentiometer

This DC self-contained flow device has a flow monitor and signal processor incorporated into one compact housing. It is ideal for monitoring liquid flow speeds in the 2 to 295 ft/min range.

The flow monitor is designed for installation directly into the pipeline by means of a pipe-tee or welded pipe socket. It is suitable for use in a 1/2 inch pipe diameter or larger.

The flow monitor probe is made of 316TI stainless steel and the housing is made of plastic. The flow monitor is rated for dynamic pressures up to 870 psi. The outputs of the monitors feature a short-circuit protected PNP transistor.

Setpoint adjustments, in reference to flow speed, are achieved by means of an adjuster located under the protective screw cap on the front of the device.

The output is de-energized when the flow speed is below the setpoint; the output is energized when flow speed is above the setpoint. Each of the six LEDs display the difference the actual flow speed in comparison to the flow speed that the setpoint is adjusted to. The LEDs operate as follows:

Red LED: flow is below set point

Yellow LED: flow is at or above set point

Green LEDs: each LED indicates a percentage of flow above the setpoint

Notes: Available with relay output. Consult factory.

## Flow Monitors DC Self Contained FCS-N1/2 A4P-AP8X-H1141

<b>Type</b>	FCS-N1/2 A4P-AP8X-H1141
ID Number	M6871032
<b>Operating Voltage</b>	19.2 - 28.8 VDC (including ripple)
Power / Current consumption	≤65 mA
<b>Output</b>	PNP transistor, short-circuit and reverse polarity protected
Switching current	≤400 mA
Voltage drop	≤1.5 V at 400 mA
<b>Temperature Range</b> (flow)	-25° to +80°C (-13° to +176°F) cont. up to +100°C (+212° F) for approx.10 min.
<b>Operating Range</b> (flow rate)	
Water	1-150 cm/s (2-295 ft/min)
Oil	3-300 cm/s (6-590 ft/min)
Repeatability	±5% of full range
<b>Time Delay Before Availability</b>	2-15 s (8 s typical)
Switch ON time (above setpoint)	1-13 s (2 s typical)
Switch OFF time (below setpoint)	1-15 s (2 s typical)
Temperature gradient	max. 250°C/min. (450°F/min.)
<b>Pressure Rating</b>	1450 psi (100 bar)
<b>LED Indications</b>	
Below setpoint, output de-energized	red
At setpoint, output energized	yellow
Above setpoint, output energized	green (4), in addition to yellow LED)
<b>Probe Material</b> (DIN 2 462/17 440)	316TI stainless steel (1.4571)
Enclosure (DIN 40 050)	IP 67, NEMA 1,3,4,4x,12,13
Temperature rating	-25° to +80°C (-13° to +176°F)
Torque	100 Nm (73.7 ft-lb)
<b>Housing Material</b>	PBT
Enclosure (DIN 40 050)	IP 67, NEMA 1, 3, 4, 4x, 12, 13
Operating temperature	-25° to +80°C (-13° to +176°F)
<b>Connection</b>	3-wire <i>euromast</i> quick disconnects RK 4T-* or WK 4T-* (Page 65) * = Length in meters

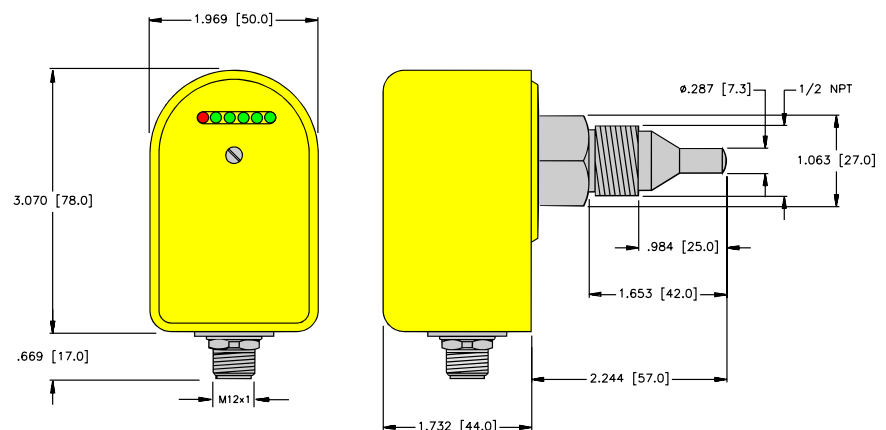
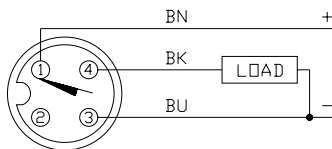

FCS-N1/2 A4P-AP8X-H1141

# TURCK

## DC Self-Contained Flow Monitors



### FCS-G1/4 A4-ARX-H1140

- All stainless steel housing
- Flow monitor and signal processor in one compact housing
- Dynamic pressure resistance up to 870 psi
- Simple adjustment by means of potentiometer
- Relay output for 60 VDC/1 A, N.O.

This DC self-contained flow device has a flow monitor and signal processor incorporated into one compact housing. It is ideal for monitoring liquid flow speeds in the 2 to 295 ft/min range.

The flow monitor is designed for installation directly into the pipeline by means of a pipe-tee or welded pipe socket. It is suitable for use in a 1/2 inch pipe diameter or larger.

The flow monitor housing is made of 316TI stainless steel, and is rated for dynamic pressures up to 870 psi.

Setpoint adjustments, in reference to flow speed, are achieved by means of an adjuster located under the protective screw cap on the front of the device.

The output is de-energized when the flow speed is below the setpoint; the output is energized when flow speed is above the setpoint. Six LEDs display the flow speed in comparison to the flow speed that the setpoint is adjusted to. The LEDs operate as follows:

Red LED: flow is below set point

Yellow LED: flow is at or above set point

Green LEDs: each LED indicates a percentage of flow above the setpoint

## Flow Monitors DC Self Contained with Relay Output FCS-G1/4 A4-ARX-H1140

<b>Type</b> ID Number	FCS-G1/4 A4-ARX-H1140 M6870102
<b>Operating Voltage</b> Power / Current consumption	24 VDC $\pm$ 20% $\leq$ 70 mA
<b>Output</b> Switching current Switching Voltage Switching Capacity	$\leq$ 1 A $\leq$ 60 VDC $\leq$ 60 W
<b>Temperature Range</b> (fluid)	-25° to +80°C (-13° to +176°F) cont.
<b>Operating Range</b> (flow rate) Water Oil Repeatability	1-150 cm/s (2-295 ft/min) 3-300 cm/s (6-590 ft/min) $\pm$ 5% of full range
<b>Time Delay Before Availability</b> Switch ON time (above setpoint) Switch OFF time (below setpoint) Temperature gradient	2-15 s (8 s typical) 1-13 s (2 s typical) 1-15 s (2 s typical) max. 250°C/min. (450°F/min.)
<b>Pressure Rating</b>	1450 psi (100 bar)
<b>LED Indications</b> Below setpoint, output de-energized At setpoint, output energized Above setpoint, output energized	red yellow green (4)
<b>Housing Material</b> (DIN 2 462/17 440) Enclosure (DIN 40 050) Operating temperature Torque	316TI stainless steel (1.4571) IP 67, NEMA 1,3,4,4x,12,13 -25° to +80°C (-13° to +176°F) 100 Nm (73.7 ft-lb)
<b>Connection</b>	4-wire <b>eufofast</b> quick disconnect 150 m max. cable length (22 AWG) RK 4.4T-* or WK 4.4T-* (page 65) * = length in meters

**Note:** G threading refers to British parallel pipe (BSPP) threading.

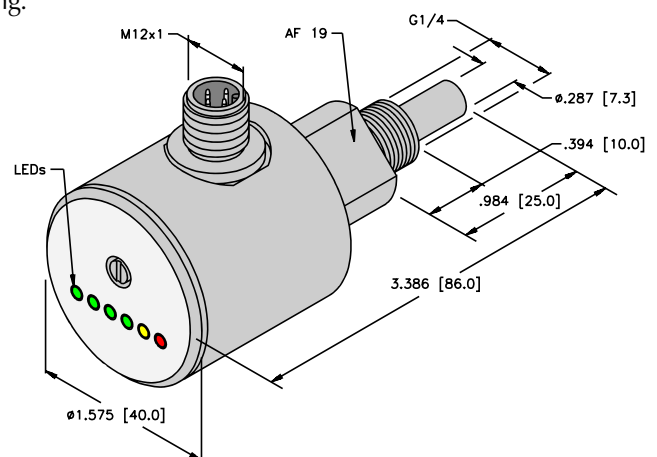
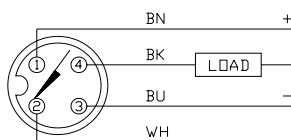

FCS-G1/4 A4-ARX-H1140

# TURCK

## DC Self-Contained Flow Monitors



### FCS-N1/2 A4P-LIX-H1141

- Flow monitor and signal processor in one compact unit
- Housing made of Crastin
- Pressure resistant up to 435 psi
- Current output from 4 to 20 mA
- Enclosure meets IP 67
- Simple adjustment by means of potentiometer

The FCS-N1/2 A4P-LIX-H1141 series incorporates the flow monitor and signal processor into one compact housing. These devices are ideal for monitoring liquid flow speeds in the 5 to 150 cm/s range.

The flow monitor is designed for installation into the pipeline by means of a pipe tee or welded pipe socket. It is suitable for a wide variety of pipe diameters.

The 1/2 NPT thread mounting is pressure resistant up to 435 psi. A V/I signal converter converts the internal analog voltage signal into a standard 4 to 20 mA analog current signal.

A potentiometer serves for Analog adjustments in reference to the flow speed. At maximum flow speed, the output of the monitor is 20 mA. The output signal is factory preset for 20 mA at 150 cm/s (water). The 20 mA output is adjustable from 50 cm/s to 150 cm/s.

Six LEDs display the output signal based on the flow velocity.

Note: Flow settings are factory calibrated for water at 20°C. The settings are 4 mA at approx. 5 cm/s and 20 mA at approx. 150 cm/s.

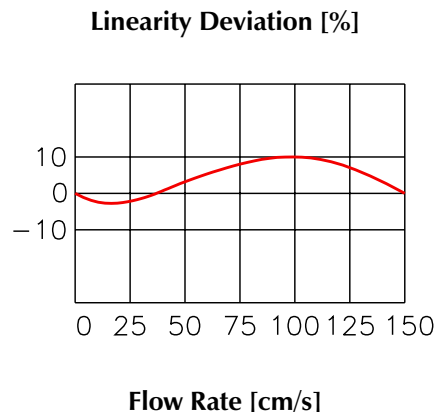
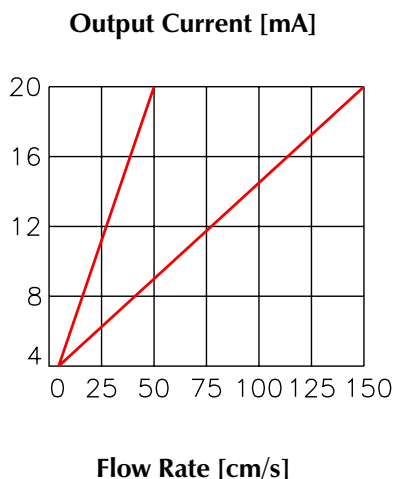

## Flow Monitors DC Self Contained Linear Analog Output FCS-N1/2 A4P-LIX-H1141

<b>Type</b>	FCS-N1/2 A4P-LIX-H1141
ID Number	M6871041
<b>Operating Voltage</b>	21.6 to 26.4 VDC (includes ripple)
Power / Current consumption	≤100 mA
<b>Output</b>	current output
Load	≤500 Ω
Output current	4 to 20 mA (25 mA max.)
Linearity Deviation	≤10%
<b>Temperature Range</b> (flow)	-25° to 75°C (-13° to 167°F)
<b>Operating Range</b> (flow rate)	
Water	5-150 cm/s
<b>Time Delay Before Availability</b>	2-15 s (8 s typical)
Response time	1-15 s
<b>Pressure Rating</b>	435 psi (30 bar)
<b>LED Indications</b>	
Output status	5 green, 1 red
1 to 6 illuminate:	
- LED 6	≥20 mA
- LED 5	>16 mA
- LED 4	>12 mA
- LED 3	> 8 mA
- LED 2	> 4 mA
- LED 1 (red)	= 4 mA
<b>Probe Material</b> (DIN 2 462/17 440)	316TI stainless steel (1.4571)
Enclosure (DIN 40 050)	IP 67, NEMA 1,3,4,4x,12,13
Torque	100 Nm (73.7 ft-lb)
<b>Housing Material</b>	PBT
Enclosure (DIN 40 050)	IP 67, NEMA 1,3,4,4x,12,13
Operating temperature	-25° to 80°C (-13° to 176°F)
<b>Connection</b>	3-wire <b>euromast</b> ® quick disconnects
Mating cordset	RK 4T-* or WK 4T-* (page 65) * = Length in meters
<b>Accessories</b>	2 sealing rings 1 screwdriver for span adjustment

