

Ethernet-PROFIBUS-Interface PB-XEPI

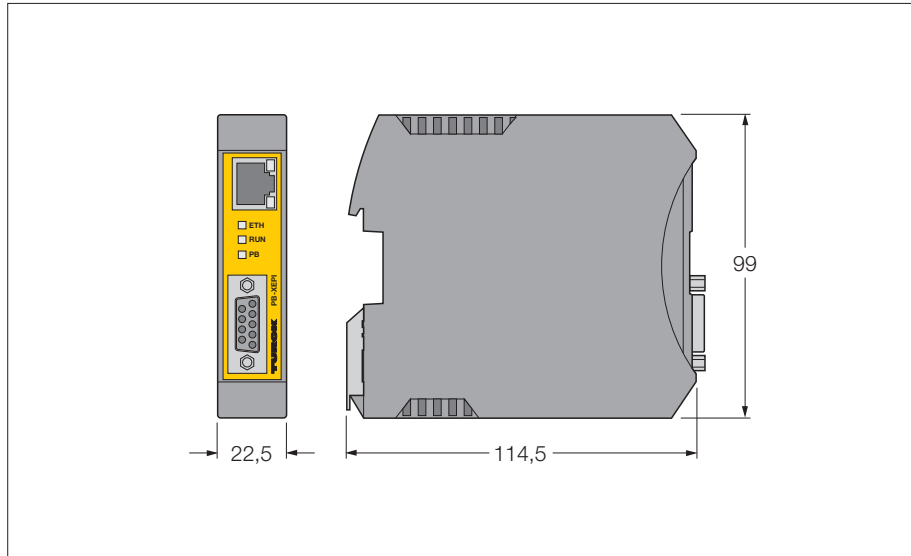

- Support of the the FDT/DTM technology
- Support of the “PROFIBUS Scope“ diagnosis tool from TREBING + HIMSTEDT
- Central field device configuration, parameterization and diagnosis
- Ethernet-PROFIBUS-HART® connection via remote I/O system *excom*®
- Ethernet-PROFIBUS-PA connection via link/coupler
- Independent of process control system or SPS manufacturers
- Condition-Monitoring
- Asset-Management

The compact PB-XEPI interface allows easy connection of PROFIBUS networks to Ethernet. It supports a large number of international open standards on one single hardware platform, including the FDT/DTM standard of *excom*®.

The interface forms the basis for modern field devices and Asset-Management approaches with central configuration, calibration, diagnosis and Condition-Monitoring.

Because the gateway supports numerous open standards, various configuration tools of leading manufacturers such as FieldCare (Endress + Hauser), PACTware™ (PACTware™ Consortium) or Emerson’s AMS Suite can be operated with the same device platform.

The gateway can be integrated into both existing and new systems – independent from process control systems or SPS manufacturers.

The gateway allows flexible concepts and manufacturer-independent solutions for continuous vertical integration of production processes.

The gateway features one PROFIBUS and one Ethernet interface.

The installation width is merely 23 mm.

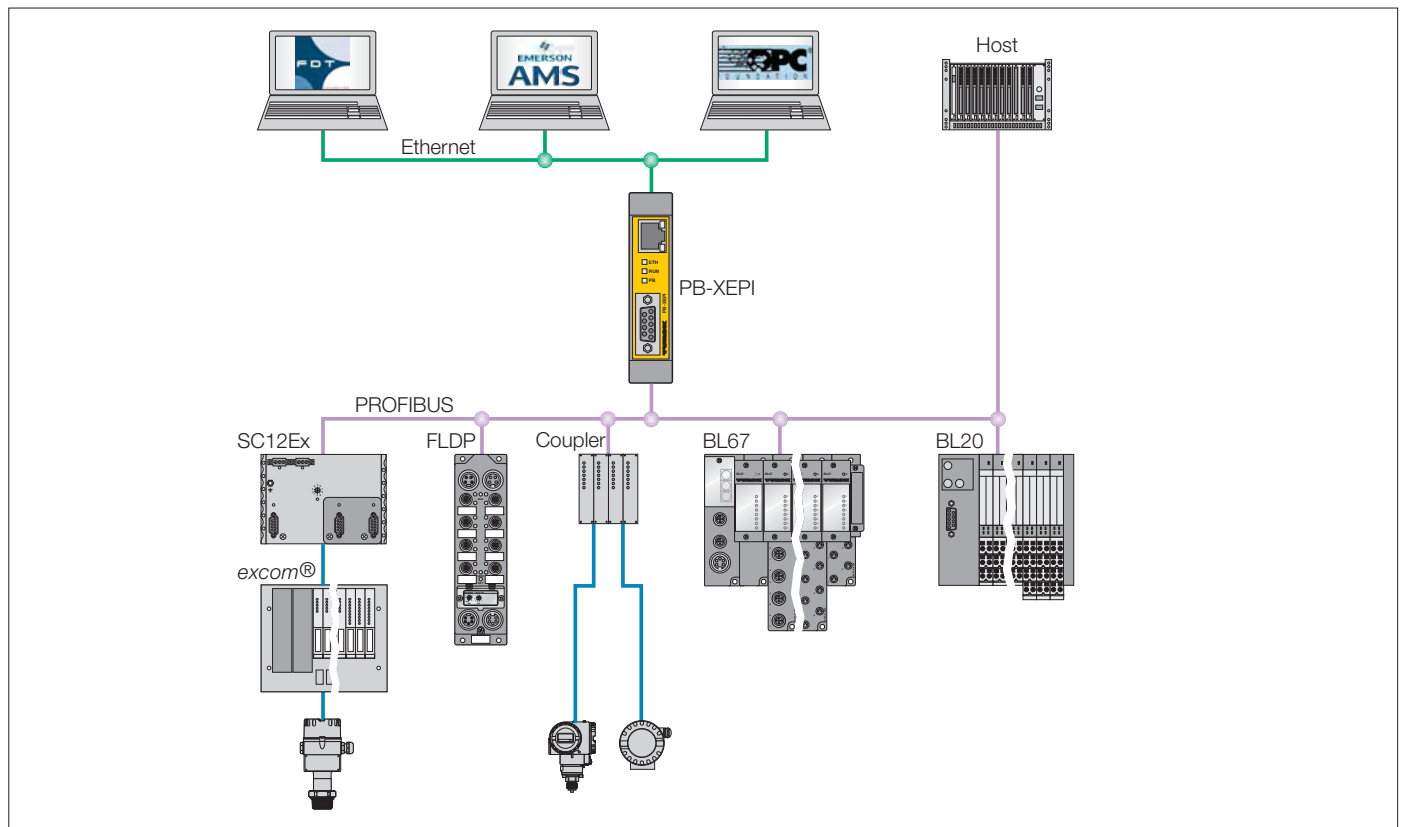

Ethernet-PROFIBUS-Interface PB-XEPI

Type	PB-XEPI (incl. CommDTM PROFIBUS DP-V1 software for FDT frame application compliant with FDT Specification 1.2 + Addendum. Device can also be used for PROFIBUS Diagnosis with the "PROFIBUS Scope" from TREBING + HIMSTEDT)
Ident-No.	6905313
Supply voltage U_B	24 VDC (19.2...28.8 VDC)
Current consumption	≤ 200 mA
Transfer rate PROFIBUS	max. 12 Mbps (max. 1.5 Mbps with diagnosis software "PROFIBUS Scope")
PROFIBUS interface	9-pole SUB-D (RS485)
Ethernet interface	RJ45 (10Base-T/100Base-TX)
Operating temperature range	0...50 °C
Mounting	35 mm DIN top hat rail
Dimensions B x H x T	22.5 x 99 x 114.5 mm
Weight	120 g
System requirements	
Operating systems	Windows® 2000/XP



D301147 0308