

TURCK

Pressure Sensors

PT4500 & PT4510 Submersible Pressure Transmitters

- **UL/cUL 913 (CSA 157) Class 1 Div 1 Groups C, D** when installed with an approved barrier per control drawing IS1.904
- **High Strength Stainless Steel Construction**
- **Ranges from 0-2.5 PSIG up to 0-100 PSIG**
- **Compatible with Wide Range of Liquids**
- **EMI/RFI Protection**



The PT4500 and PT4510 are submersible pressure transmitters that when installed with approved barrier like the IM33 are UL/cUL913. Submersible pressure transmitters are used to monitor continuous level in indoor and outdoor applications. The PT4510 is for low level applications up to 400 inches of range. The PT4500 is available in ranges up to 100 psig.

Applications

Liquid tanks
Gasoline and diesel tanks
Wastewater canals
Irrigation

Performance @25°C (77°F)

Accuracy*	<±0.25% BFSL
Stability (1 year)	±0.25%FS, typ
Over range protection	2X rated pressure
Burst pressure	5X or 1,250 psi (whichever is less)
Pressure cycles	> 50 million

* Accuracy includes non-linearity, hysteresis & non-repeatability

Environmental Data

Operating temperature	-40 to +85°C (-40 to +185°F)
Storage temperature	-40 to +100°C (-40 to +212°F)
Compensated Range	0 to +55°C (30 to +130°F)
TC zero	<±1.5% of FS
TC span	<±1.5% of FS
Vibration test	10G peak, 20 to 2000 Hz
Shock test	100G, 11 msec, 1/2 sine
EMI/RFI protection	Yes
Rating	IP 68

Electrical Data

Output	4-20mA
Excitation	10-28 VDC
Output impedance	>10k Ω
Current consumption	20 mA, typ
Bandwidth	(-3dB): DC to 250 Hz
Output noise	-
Zero offset	<±1% of FS
Span tolerance	<±2% of FS
Output load	0-800 Ω @10-28 VDC
Reverse polarity protection	Yes

Class 1 Div 1 Pressure Transmitters Part Number Key

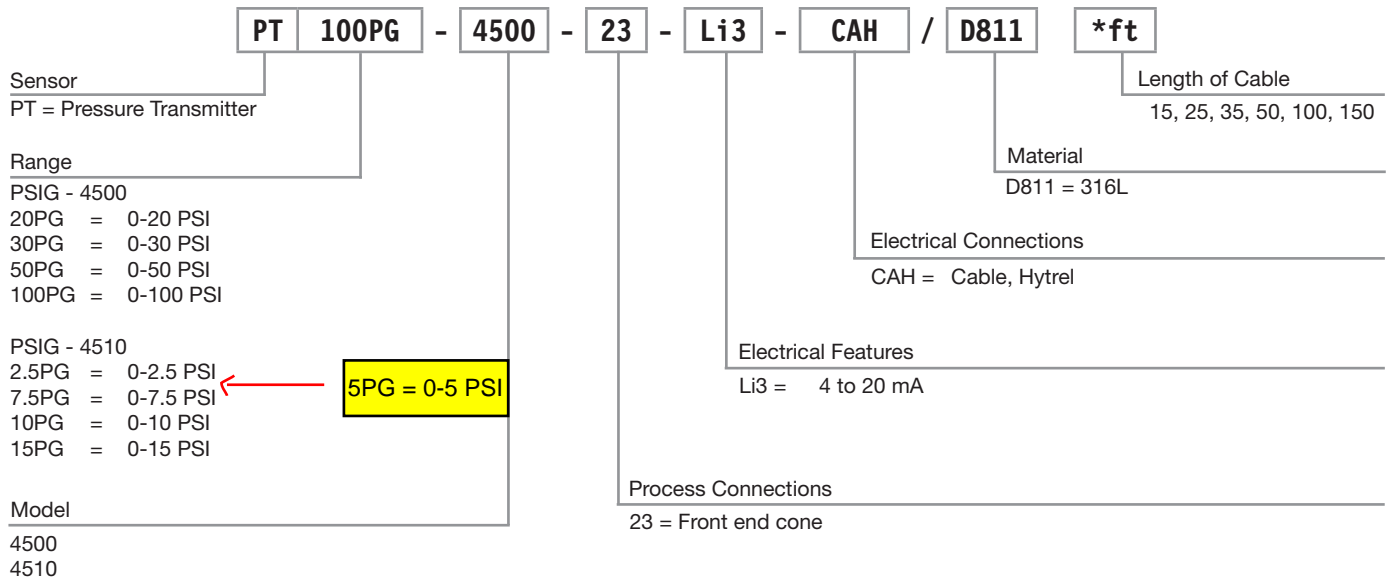

Dimensional Drawings

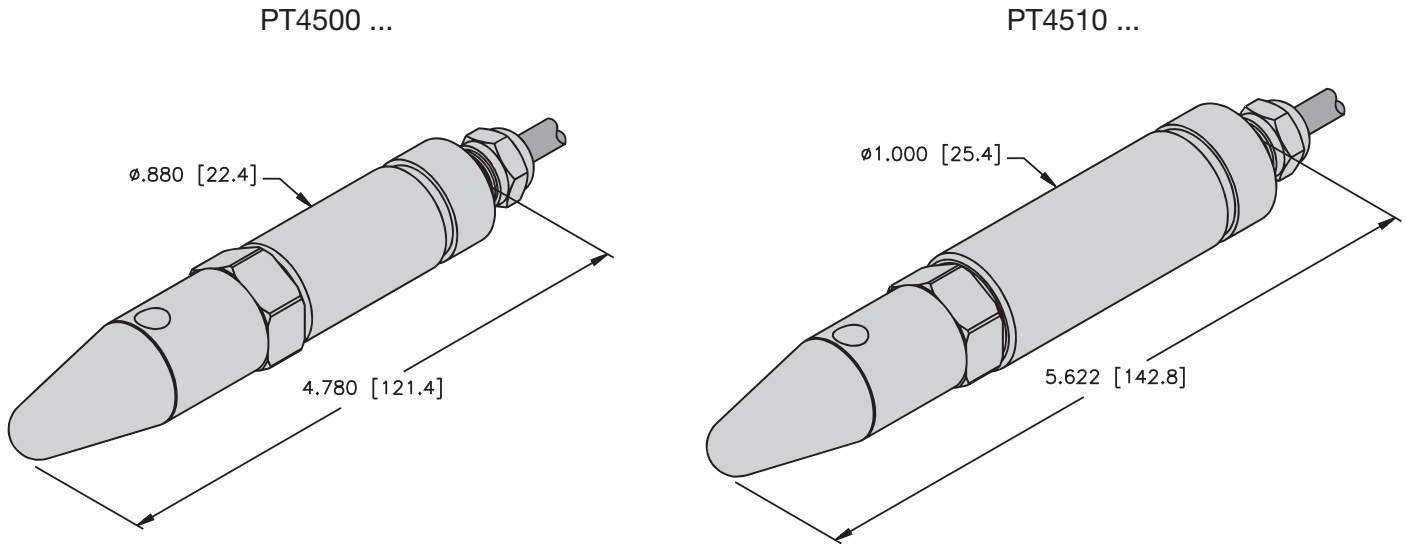

PT4500 & PT4510 Wiring Instructions Using IM33-11EX-Hi/24VDC

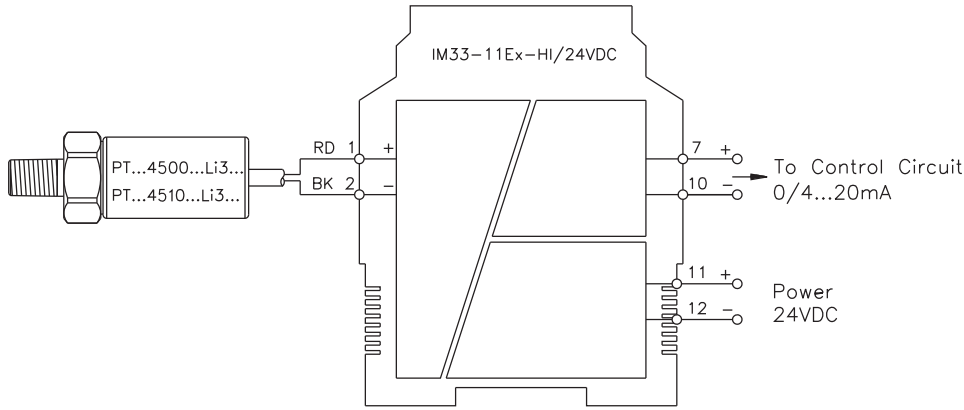

PT4500 & PT4510 Wiring Instructions

HAZARDOUS LOCATION
CLASS I, DIVISION 1
Group C, or D

Intrinsic Safety
Associated Apparatus

See Table below for electrical connections

UL Listed TURCK Inc. pressure transducer models:
 PT *abc*-4400-*d-e-f/g/h*
 PT *abc*-4410-*d-e-f/g/h*
 PT *abc*-44LP-*d-e-f/g/h*
a = Pressure rating in bar, inH2O, KG/cm², or psi
b = Pressure units B, H, K or P
e = Pressure measurement type A, G, V
d = Process connection 02, 03, 04, 05, 12, 13, 14, 15, 16, 17, 18, 19, 20, 21, 22, 24, 25, 27, or 28
e = Output type Li3, LU4, LU61, LU62, LU63, LU64, LU65, LU66, LU69, LU70, LU71, or LU72
f = Electrical connection H1141, VAS, VBS, VCS, MP150, BDX4, BDX6, CA244, or CO244
g = Wetted parts material D810, D811, D812, or D813
h = Cable length/units or blank

Entity Parameters
 V_{max} = 28V
 I_{max} = 175mA
 C_i = 0.44µF
 L_i = 0

PT *abc*-4500-*d-e-f/g/h*
 PT *abc*-4510-*d-e-f/g/h*
 PT *abc*-4520-*d-e-f/g/h*
a = Pressure rating in bar, inH2O, KG/cm², or psi
b = Pressure units B, H, K or P
c = Pressure measurement type A, G, V
d = Process connection 03, 04, 14, 15, 23, 30 or 31
e = Output type Li3, LU4, LU62, LU64, LU70 or LU71
f = Electrical connection CAH or CAK
g = Wetted parts material D810, D811, D812, D813 or D814
h = Cable length/units or blank

Electrical Connections per Output Type

Output Type Option Code	H1141		Wide Pin VAS			Wide Pin VBS			Wide Pin VCS			MP150			BDX6			BDX4			CAH, CAK, CA244, & CO244				
	Pin1	Pin2	Pin3	Pin4	Pin1	Pin2	Pin3	Wide Pin	Pin1	Pin2	Pin3	Wide Pin	PinA	PinB	PinC	PinA	PinB	PinC	PinD	PinE	PinF	Red	Blk	Grn	Wht
Li3	V+	n/c	Gnd	n/c	V+	Gnd	n/c	n/c	n/c	Gnd	V+	n/c	Gnd	V+	n/c	V+	Gnd	n/c	n/c	+	+	V+	Gnd	na	na
LU4, LU61, LU62, LU63, LU64, LU65, LU66, LU69	V+	n/c	Gnd	S+	V+	Gnd	S+	n/c	S+	Gnd	V+	n/c	Gnd	V+	S+	V+	S+	n/c	Gnd	+	+	V+	Gnd	na	S+
LU70, LU71, LU72	V+	S+	S-	Gnd	S+	Gnd	V+	S-	S+	Gnd	V+	S-	na	na	na	V+	S+	S-	Gnd	+	+	V+	Gnd	S+	S-

* n/c for BDX6, na for BDX4

The transducers depicted above are approved for installation in a Class I, Division 1, Group C or D hazardous location when connected to associated apparatus as described in note 1.

Notes:

- The associated apparatus must have entity parameters that meet the following requirements:
 V_{oc} or V_t ≤ V_{max} I_{sc} or I_t ≤ I_{max}
 C_a ≥ C_i + C_{cable} L_a ≥ L_i + L_{cable}
 I_{max} must be greater than the total current from the associated apparatus under any condition. This may be represented by I_{sc} or, in the case of multiple channel or multiple apparatus connections, I_{max}.
- Associated apparatus must not be connected to any device that uses or generates in excess of 250Vrms.
- Installation must be in accordance with the National Electrical Code, ANSI/NFPA 70, Article 504.

A Release

Rev	Description	BVL	1/20/09
		Drft	Date

Drawing No.:
IS-1.904

TURCK
3000 Campus Drive
Plymouth, MN 55441
Phone: (763) 663-7900

Title: Control Drawing for UL Listed Intrinsically Safe PT .. -4..0-...-./.. and PT .. -44LP-...-./.. Pressure Transducers

Scale: NONE **Sheet** 1 of 1