

VACON 20
AC DRIVES

QUICK GUIDE

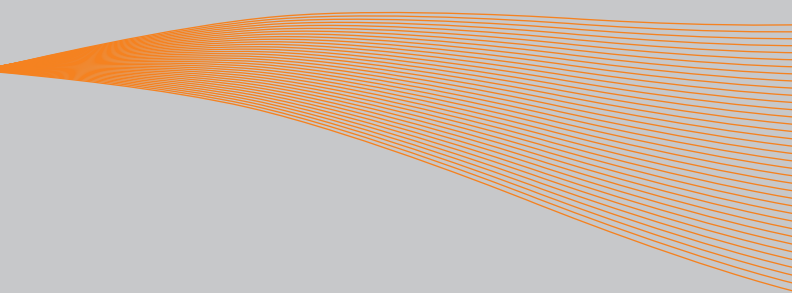

Clearwater Tech - Phone: 800.894.0412 - Fax: 208.368.0415 - Web: www.clrwtr.com - Email: info@clrwtr.com

VACON
DRIVEN BY DRIVES

This quick guide includes the essential steps for easy installation and setup of your Vacon 20 frequency converter. Before commissioning your drive, download and read the complete Vacon 20 User Manual available at Vacon website -> Support & Downloads

1. SAFETY



ONLY A COMPETENT ELECTRICIAN IS ALLOWED TO CARRY OUT THE ELECTRICAL INSTALLATION!

This quick guide contains clearly marked warnings which are intended for your personal safety and to avoid any unintentional damage to the product or connected appliances.

Please read these warnings carefully:



The components of the power unit of the frequency converter are live when Vacon 20 is connected to mains. Coming into contact with this voltage is extremely dangerous and may cause death or severe injury.



The motor terminals U, V, W (T1, T2, T3) and the possible brake resistor terminals - / + are live when Vacon 20 is connected to mains, even if the motor is not running.



The control I / O-terminals are isolated from the mains potential. However, the relay output terminals may have a dangerous control voltage present even when Vacon 20 is disconnected from mains.



The earth leakage current of Vacon 20 frequency converters exceeds 3.5 mA AC. According to standard EN61800-5-1, a reinforced protective ground connection must be ensured. **See Chapter 7!**



If the frequency converter is used as a part of a machine, the machine manufacturer is responsible for providing the machine with a main switch [EN 60204-1].



If Vacon 20 is disconnected from mains while running the motor, it remains live if the motor is energized by the process. In this case the motor functions as a generator feeding energy to the frequency converter.



After disconnecting the frequency converter from the mains, wait until the fan stops and the display segments or status leds on the front panel go out. Wait 5 more minutes before doing any work on Vacon 20 connections.



The motor can start automatically after a fault situation, if the autoreset function has been activated.

2. INSTALLATION

2.1 Mechanical installation

There are two possible ways to mount Vacon 20 in the wall. For MI1 - MI3, either screw or DIN-rail mounting; For MI4 - MI5, screw or flange mounting.

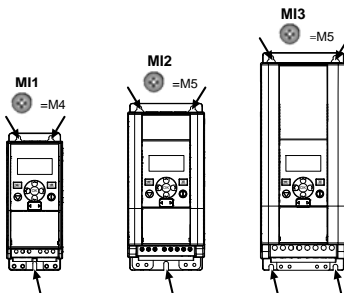

Figure 1: Screw mounting, MI1 - MI3

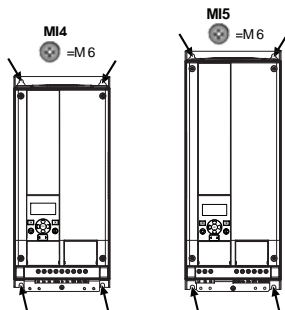

Figure 2: Screw mounting, MI4 - MI5

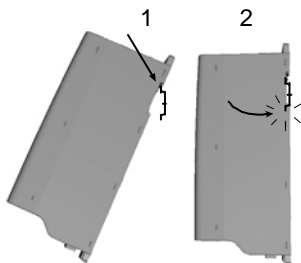

Figure 3: DIN-rail mounting, MI1 - MI3

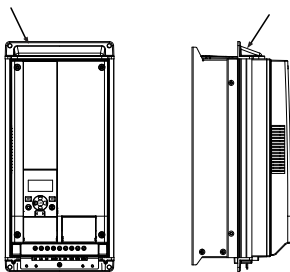

Figure 4: flange mounting, MI4 - MI5

Note! See the mounting dimensions on the back of the drive.
 Leave **free space** for cooling above (**100 mm**), below (**50 mm**), and on the sides (**20 mm**) of Vacon 20! (For MI1 - MI3, side-to-side installation allowed only if the ambient temperature is below 40 °C; For MI4 - MI5, side-to-side installation is not allowed.)

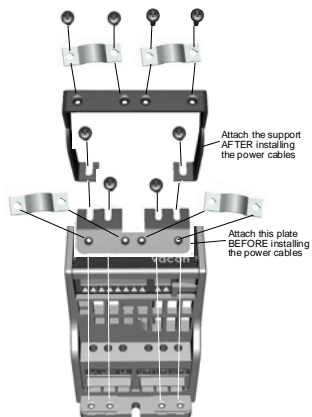

Figure 5: Attaching the PE-plate and API cable support, MI1 - MI3

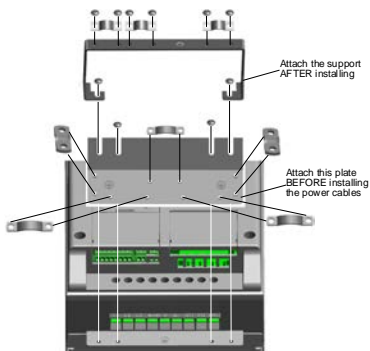

Figure 6: Attaching the PE-plate and API cable support, MI4 - MI5

2.2 Cabling and connections

2.2.1 Power cabling

Note! Tightening torque for power cables is 0.5 - 0.6 Nm

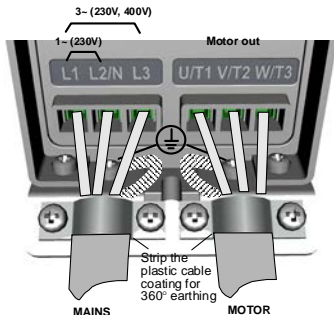

Figure 7: Vacon 20 power connections, MI1

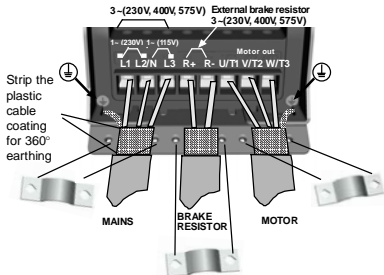

Figure 8: Vacon 20 power connections, MI2 - MI3

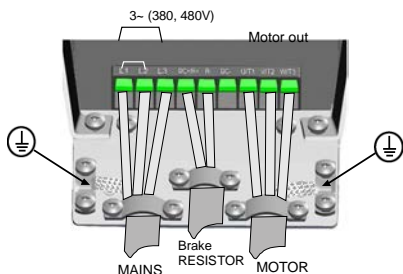

Figure 9: Vacon 20 power connections, MI4

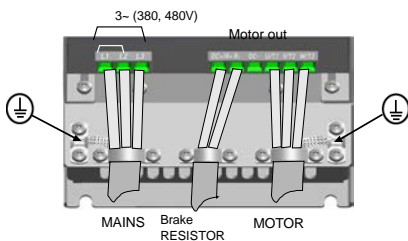

Figure 10: Vacon 20 power connections, MI5

2.2.2 Control cabling

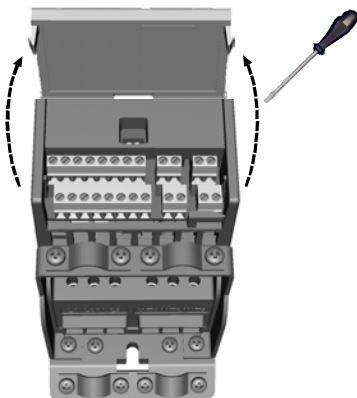

Figure 11: Open the lid MI1 - MI3

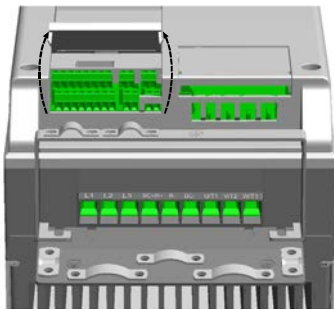

Figure 12: Open the lid MI4 - MI5

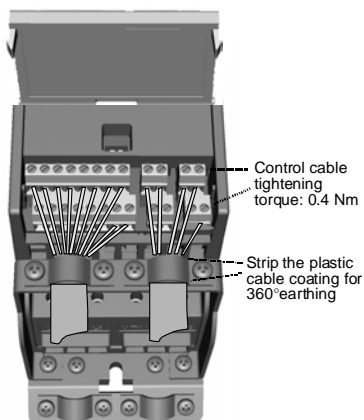

Figure 13: Install the control cables, MI1 - MI3

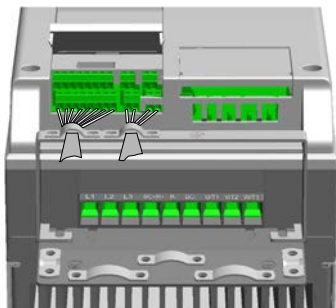
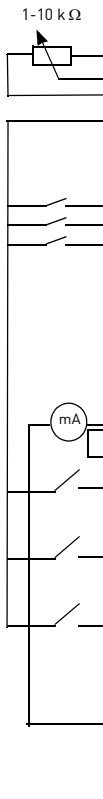

Figure 14: Install the control cables, MI4 - MI5

3. CONTROL I / O AND TERMINALS

Vacon 20



Terminal	Signal	Factory preset	Description
1	+10 Vre	Ref. voltage out	Maximum load 10 mA
2	AI1	Analog signal in 1	Freq. reference ^{P1} 0 - 10 V, Ri >= 200 kΩ
3	GND	I / O signal ground	
6	24 Vout	24 V output for DI's	±20 %, max. load 50 mA
7	DI_C	Digital Input Commom	Digital Input Commom for DI1- DI6, refer to Table 2 for DI sink type
8	DI1	Digital input 1	Start forward ^{P1} 18 - 30 V, Ri > 5 kΩ
9	DI2	Digital input 2	Start reverse ^{P1}
10	DI3	Digital input 3	Fault reset ^{P1}
A	A	RS485 signal A	FB Communication Negative
B	B	RS485 signal B	FB Communication Positive
4	AI2	Analog signal in 2	PID actual value and Freq. reference ^{P1} Default: 0(4) - 20 mA, Ri <= 250 Ω Other: 0 - 10 V, Ri >= 200 kΩ Selectable through microswitch
5	GND	I / O signal ground	
13	DO-	Digital Output Commom	Digital Output Commom
14	DI4	Digital input 4	Preset speed B0 ^{P1} 18 - 30 V, Ri > 5 kΩ
15	DI5	Digital input 5	Preset speed B1 ^{P1} As DI, Other: Encoder Input A (frequency up to 10 kHz) Selectable through microswitch
16	DI6	Digital input 6	External Fault ^{P1} As DI, Other: Encoder Input B (frequency up to 10 kHz), Pulse Train Input (frequency up to 5 kHz)
18	AO	Analog Output	Output frequency ^{P1} 0 - 10 V, RL > 1 KΩ 0(4) - 20 mA, RL < 500 Ω Selectable through microswitch
20	DO	Digital signal out	Active = READY ^{P1} Open collector, max. load 48 V / 50 mA

Table 1: Vacon 20 General purpose application default I / O configuration and connections for control board

^{P1} = Programmable function, See User Manual: parameter lists and descriptions for detail

Terminal	Signal	Factory preset	Description
22	RO 13	Relay out 1	Max. switching load: 250 Vac / 2 A or 250 Vdc / 0.4 A
23	RO 14		
24	RO 22	Relay out 2	Max. switching load: 250 Vac / 2 A or 250 Vdc / 0.4 A
25	RO 21		
26	RO 24		
		Active = RUN ^{P)}	
		Active = FAULT ^{P)}	

Table 1: Vacon 20 General purpose application default I / O configuration and connections for control board
P) = Programmable function, See User Manual: parameter lists and descriptions for detail

Terminal	Signal	Factory preset	Description
3	GND	I / O signal ground	
6	24 Vout	24 V output for DI's	±20 %, max. load 50 mA
7	DI_C	Digital Input Com- mum	Digital Input Commom for DI1-DI6
8	DI1	Digital input 1	Start forward ^{P)}
9	DI2	Digital input 2	Start reverse ^{P)}
10	DI3	Digital input 3	Fault reset ^{P)}
14	DI4	Digital input 4	Preset speed B0 ^{P)}
			18 - 30 V, Ri > 5 kΩ
15	DI5	Digital input 5	Preset speed B1 ^{P)}
			As DI, Other: Encoder Input A (frequency up to 10 kHz) Selectable through microswitch
16	DI6	Digital input 6	External Fault ^{P)}
			As DI, Other: Encoder Input B (frequency up to 10 kHz), Pulse Train Input (fre- quency up to 5 kHz)

Table 2: DI Sink Type, remove jumper J500 and connect the wire using table 2

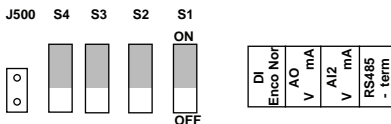
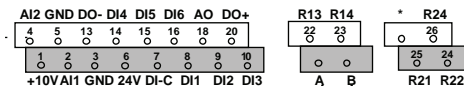

Figure 1: Microswitches

Vacon 20 I / O terminals:



4. NAVIGATION & STARTUP

4.1 The main menus of Vacon 20

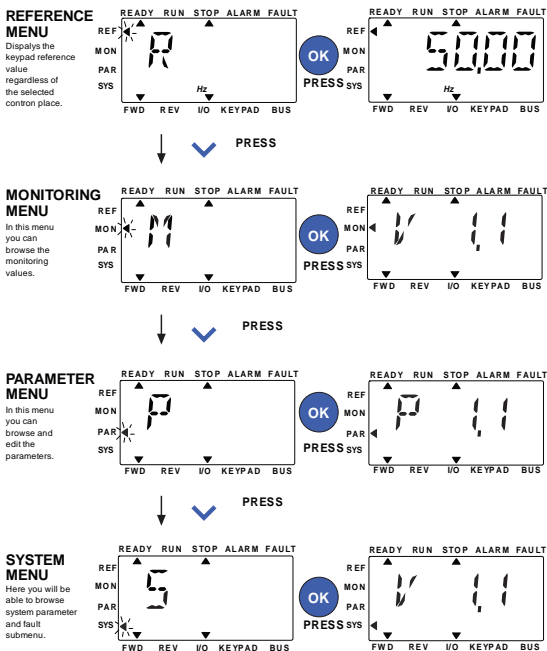

Figure 16: The main menu of Vacon 20

4.2 Commissioning and startup wizard

4.2.1 Commissioning steps:

1. Read safety instructions on page 1	7. Perform test run without motor, see the User Manual
2. Secure the grounding and check that cables comply with requirements	8. Run no-load tests without motor being connected to the process
3. Check quality and quantity of cooling air	9. Perform an identification run Par. ID631
4. Check that all start / stop switches are in STOP position	10. Connect the motor to the process and perform test run once again
5. Connect the drive to mains	11. Vacon 20 is now ready for use
6. Run the Startup wizard and set all necessary parameters	

Table 3: Commissioning steps

4.2.2 Startup wizard

Vacon 20 runs the startup wizard in first power-up. The wizard can be run by setting SYS Par.4.2 =1. The following figures show the procedure.

NOTE! Running the startup wizard will always return all parameter settings to their factory defaults!

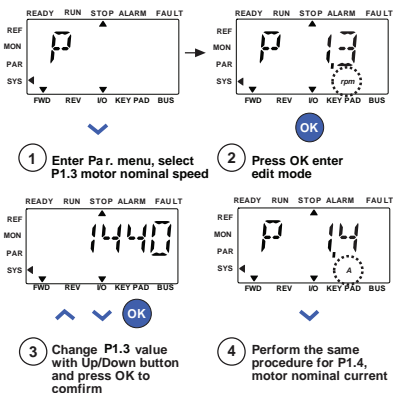
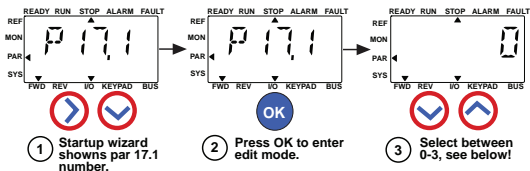

Figure 17: Vacon 20 startup wizard (standard application)



Selections:

	P1.1	P1.2	P1.7	P1.8	P1.15	P2.1	P2.2	P2.3	P3.1	P3.2	P3.3	P4.2	P4.3
0 = Basic	v	50/60 Hz	1.5 x InMOT	0= Frequency control	0= Not used	I/O	0= Ramp	0= Coast	0 Hz	50/60 Hz	4=AI1 0-10V	3s	3s
1 = Pump drive	v	50/60 Hz	1.1 x InMOT	0= Frequency control	0= Not used	I/O	0= Ramp	1= Ramp	20 Hz	50/60 Hz	4=AI1 0-10V	5s	5s
2 = Fan drive	v	50/60 Hz	1.1 x InMOT	0= Frequency control	0= Not used	I/O	1= Flying	0= Coast	20 Hz	50/60 Hz	4=AI1 0-10V	20s	20s
3 = High Torque drive	v	50/60 Hz	1.5 x InMOT	1=Open loop speed control	1= used	I/O	0= Ramp	0= Coast	0 Hz	50/60 Hz	4=AI1 0-10V	1s	1s

*Same as drive voltage, except in 115V drives this value is 230V

Parameters affected:

- P1.1 Motor Un (V)
- P1.2 Motor fn (Hz)
- P1.7 Current limit (A)
- P1.8 Motor control mode
- P1.15 Torque boost
- P2.1 Control place
- P2.2 Start function
- P2.3 Stop function
- P3.1 Min frequency
- P3.2 Max frequency
- P3.3 I/O reference
- P4.2 Acc. time (s)
- P4.3 Dec time (s)

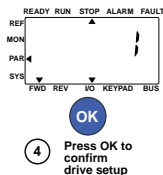

Figure 18: Drive setup

5. MONITORING & PARAMETERS

NOTE! This guide is for Vacon 20 standard application, if you are using a special application, please download the application manual on: Vacon website -> Support & downloads.

5.1 Monitoring values

Code	Monitoring signal	Unit	ID	Description
V1.1	Output frequency	Hz	1	Output frequency to motor
V1.2	Frequency reference	Hz	25	Frequency reference to motor control
V1.3	Motor speed	rpm	2	Calculated motor speed
V1.4	Motor current	A	3	Measured motor current
V1.5	Motor torque	%	4	Calculated actual / nominal torque of the motor
V1.6	Output Power	KW	79	Output power from drive to motor
V1.7	Motor voltage	V	6	Motor voltage
V1.8	DC-link voltage	V	7	Measured DC-link voltage
V1.9	Drive temperature	°C	8	Heatsink temperature
V1.10	Motor temperature	%	9	Calculated motor temperature
V1.11	Motor shaft power	%	5	Calculated actual / nominal power of the motor
V2.1	Analog input 1	%	13	AI1 signal range in percent of used range
V2.2	Analog input 2	%	14	AI2 signal range in percent of used range
V2.3	Analog output	%	26	AO signal range in percent of used range
V2.4	Digital input status DI1, DI2, DI3		15	Digital input status
V2.5	Digital input status DI4, DI5, DI6		16	Digital input status
V2.6	RO1, RO2, DO		17	Relay / digital output status
V2.7	Pulse train / encoder input	%	1234	0 - 100% scale value
V2.8	Encoder rpm	rpm	1235	Scaled according to Encoder pulses / revolution parameter

Table 4: Vacon 20 monitoring values (General purpose application)

Code	Monitoring signal	Unit	ID	Description
V3.1	Drive Status Word		43	Bit codes status of drive B0 = Ready B1 = Run B2 = Reverse B3 = Fault B6 = RunEnable B7 = AlarmActive B12 = RunRequest B13 = MotorRegulatorActive
V3.2	Application Status Word		89	Bit codes status of application: B3 = Ramp 2 Active B5 = Remote CTRL Place 1 active B6 = Remote CTRL Place 2 active B7 = Fieldbus Control Active B8 = Local Control Active B9 = PC Control Active B10 = Preset Frequencies Active
V3.3	DIN Status Word		56	
V4.1	PID setpoint	%	20	Regulator setpoint
V4.2	PID feedback value	%	21	Regulator actual value
V4.3	PID error	%	22	Regulator error
V4.4	PID output	%	23	Regulator output
V4.5	Process		29	Scaled process variable see par. 15.18

Table 4: Vacon 20 monitoring values (General purpose application)

5.2 Quick setup parameters (Virtual menu, shows when par. 17.2 = 1)

Code	Parameter	Min	Max	Unit	Default	ID	Note
P1.1	Motor nominal voltage	180	690	V	Varies	110	Check rating plate on the motor.
P1.2	Motor nominal frequency	30,00	320,00	Hz	50,00 / 60,00	111	Check rating plate on the motor.
P1.3	Motor nominal speed	30	20000	rpm	1440 / 1720	112	Default applies for a 4-pole motor.
P1.4	Motor nominal current	0,2 x I _{Nunit}	2,0 x I _{Nunit}	A	I _{Nunit}	113	Check rating plate on the motor.
P1.5	Motor cos Φ	0,30	1,00		0,85	120	Check rating plate on the motor.
P1.7	Current limit	0,2 x I _{Nunit}	2 x I _{Nunit}	A	1.5 x I _{Nunit}	107	Maximum motor current
P1.15	Torque boost	0	1		0	109	0 = Not used 1 = Used
P2.1	Remote control place 1 selection	0	2		0	172	0 = I / O terminal 1 = Fieldbus 2 = Keypad
P2.2	Start function	0	1		0	505	0 = Ramp 1 = Flying start
P2.3	Stop function	0	1		0	506	0 = Coasting 1 = Ramp
P3.1	Min frequency	0,00	P3.2	Hz	0,00	101	Minimum freq reference
P3.2	Max frequency	P3.1	320,00	Hz	50,00 / 60,00	102	Maximum freq reference
P3.3	Remote Control Place 1 frequency reference selection	1	9		7	117	1 = Preset Speeds 0 2 = Keypad 3 = Fieldbus 4 = AI1 5 = AI2 6 = PID 7 = AI1 + AI2 8 = Motor potentiometer 9 = Pulse train / Encoder
P3.4	Preset speed 0	P3.1	P3.2	Hz	5,00	124	Preset speed 0 is used as frequency reference when P3.3 = 1
P3.5	Preset speed 1	P3.1	P3.2	Hz	10,00	105	Activated by digital inputs
P3.6	Preset speed 2	P3.1	P3.2	Hz	15,00	106	Activated by digital inputs

Table 5: Quick setup parameters

Code	Parameter	Min	Max	Unit	Default	ID	Note
P3.7	Preset speed 3	P3.1	P3.2	Hz	20,00	126	Activated by digital inputs
P4.2	Acceleration time 1	0,1	3000,0	s	3,0	103	Acceleration time from 0 Hz to maximum frequency.
P4.3	Deceleration time 1	0,1	3000,0	s	3,0	104	Deceleration time from maximum frequency to 0 Hz.
P6.1	AI1 Signal range	0	1		0	379	0 = 0 - 100% 1 = 20% - 100% 20% is the same as 2 V minimum signal level.
P6.5	AI2 Signal range	0	1		0	390	0 = 0 - 100% 1 = 20% - 100% 20% is the same as 2 V or 4 mA minimum signal level.
P14.1	Automatic reset	0	1		0	731	0 = Disable 1 = Enable
P17.2	Parameter conceal	0	1		1	115	0 = All parameters visible 1 = Only quick setup parameter group visible

Table 5: Quick setup parameters

5.3 Motor settings (Control panel: Menu PAR -> P1)

Code	Parameter	Min	Max	Unit	Default	ID	Note
P1.1	Motor nominal voltage	180	690	V	Varies	110	Check rating plate on the motor
P1.2	Motor nominal frequency	30,00	320,00	Hz	50,00 / 60,00	111	Check rating plate on the motor
P1.3	Motor nominal speed	30	20000	rpm	1440 / 1720	112	Default applies for a 4-pole motor.
P1.4	Motor nominal current	0,2 x I _{Nunit}	2,0 x I _{Nunit}	A	I _{Nunit}	113	Check rating plate on the motor
P1.5	Motor cos Φ (Power Factor)	0,30	1,00		0,85	120	Check rating plate on the motor
P1.6	Motor type	0	1		0	650	0 = Induction 1 = Permanent magnet
P1.7	Current limit	0,2 x I _{Nunit}	2 x I _{Nunit}	A	1,5 x I _{Nunit}	107	Maximum motor current
P1.8	Motor control mode	0	1		0	600	0 = Frequency control 1 = Open loop speed control
P1.9	U / f ratio	0	2		0	108	0 = Linear 1 = Quadratic 2 = Programmable
P1.10	Field weakening point	8,00	320,00	Hz	50,00 / 60,00	602	Field weakening point frequency
P1.11	Field weakening point voltage	10,00	200,00	%	100,00	603	Voltage at field weakening point as % of U _{nmot}
P1.12	U / f mid point frequency	0,00	P1.10	Hz	50,00 / 60,00	604	Mid point frequency for programmable U / f
P1.13	U / f mid point voltage	0,00	P1.11	%	100,00	605	Mid point voltage for programmable U / f as % of U _{nmot}
P1.14	Zero freq voltage	0,00	40,00	%	Varies	606	Voltage at 0 Hz as % of U _{nmot}
P1.15	Torque Boost	0	1		0	109	0 = Disabled 1 = Enabled
P1.16	Switching frequency	1,5	16,0	kHz	4,0 / 2,0	601	PWM frequency. If values are higher than default, reduce the current capacity
P1.17	Brake Chopper	0	2		0	504	0 = Disabled 1 = Enabled: Always 2 = Run state

Table 6: Motor settings

Code	Parameter	Min	Max	Unit	Default	ID	Note
P1.18	Motor identification	0	1		0	631	0 = Not active 1 = Standstill identification (need run command within 20 s to activate)
P1.19	Rs voltage drop	0,00	100,00	%	0,00	675	Voltage drop over motor windings as % of $U_{n\text{mot}}$ at nominal current.
P1.20	Overvoltage controller	0	2		1	607	0 = Disabled 1 = Enabled, Standard mode 2 = Enabled, Shock load mode
P1.21	Undervoltage controller	0	1		1	608	0 = Disable 1 = Enable
P1.22	Sine filter	0	1		0	522	0 = Not in use 1 = In use

Table 6: Motor settings

NOTE! These parameters are shown, when P17.2 = 0.

5.4 Start / stop setup (Control panel: Menu PAR -> P2)

Code	Parameter	Min	Max	Unit	Default	ID	Note
P2.1	Remote Control Place 1 Selection	0	2		0	172	0 = I / O terminals 1 = Fieldbus 2 = Keypad
P2.2	Start function	0	1		0	505	0 = Ramp 1 = Flying start
P2.3	Stop function	0	1		0	506	0 = Coasting 1 = Ramp
P2.4	I / O Start / Stop logic	0	4		2	300	I / O control signal 1 I / O control signal 2 0 Forward Backward 1 Fwd(edge) Inverted Stop 2 Fwd(edge) Bwd(edge) 3 Start Reverse 4 Start(edge) Reverse
P2.5	Local / Remote	0	1		0	211	0 = Remote control 1 = Local control
P2.6	Keypad control direction	0	1		0	123	0 = Forward 1 = Backward
P2.7	Keypad stop button	0	1		1	114	0 = Keypad control only 1 = Always
P2.8	Remote Control Place 2 Selection	0	2		0	173	0 = I / O terminals 1 = Fieldbus 2 = Keypad

Table 7: Start / stop setup

5.5 Frequency references (Control panel: Menu PAR -> P3)

Code	Parameter	Min	Max	Unit	Default	ID	Note
P3.1	Min frequency	0,00	P3.2	Hz	0,00	101	
P3.2	Max frequency	P3.1	320,00	Hz	50,00 / 60,00	102	
P3.3	Remote Control Place 1 fre- quency refer- ence selection	1	9		7	117	1 = Preset Speeds 0 2 = Keypad 3 = Fieldbus 4 = AI1 5 = AI2 6 = PID 7 = AI1+ AI2 8 = Motor potentiometer 9 = Pulse train / Encoder
P3.4	Preset speed 0	P3.1	P3.2	Hz	5,00	124	Preset speed 0 is used as frequency reference when P3.3 = 1
P3.5	Preset speed 1	P3.1	P3.2	Hz	10,00	105	Activated by digital inputs
P3.6	Preset speed 2	P3.1	P3.2	Hz	15,00	106	Activated by digital inputs
P3.7	Preset speed 3	P3.1	P3.2	Hz	20,00	126	Activated by digital inputs
P3.8	Preset speed 4	P3.1	P3.2	Hz	25,00	127	Activated by digital inputs
P3.9	Preset speed 5	P3.1	P3.2	Hz	30,00	128	Activated by digital inputs
P3.10	Preset speed 6	P3.1	P3.2	Hz	40,00	129	Activated by digital inputs
P3.11	Preset speed 7	P3.1	P3.2	Hz	50,00	130	Activated by digital inputs
P3.12	Remote Control Place 2 fre- quency refer- ence selection	1	9		5	131	As the parameter P3.3
P3.13	Motor Poten- tionmeter Ramp	1	50	Hz/s	5	331	Speed variation rate
P3.14	Motor Poten- tionmeter Reset	0	2		2	367	0 = No Reset 1 = Reset if stopped 2 = Reset if powered down

Table 8: Frequency references

NOTE! These parameters are shown, when P17.2 = 0.

5.6 Ramps and brakes setup (Control panel: Menu PAR -> P4)

Code	Parameter	Min	Max	Unit	Default	ID	Note
P4.1	Ramp S-shape	0,0	10,0	s	0,0	500	0 = Linear >0 = S-curve ramp time
P4.2	Acceleration time 1	0,1	3000,0	s	3,0	103	
P4.3	Deceleration time 1	0,1	3000,0	s	3,0	104	
P4.4	Ramp S-shape 2	0,0	10,0	s	0,0	501	
P4.5	Acceleration time 2	0,1	3000,0	s	10,0	502	
P4.6	Deceleration time 2	0,1	3000,0	s	10,0	503	
P4.7	Flux Braking	0	3		0	520	0 = Off 1 = Deceleration 2 = Chopper 3 = Full Mode
P4.8	Flux Braking Current	0,5 x I_{Nunit}	2,0 x I_{Nunit}	A	I_{Nunit}	519	
P4.9	DC Braking Current	0,3 x I_{Nunit}	2,0 x I_{Nunit}	A	I_{Nunit}	507	Defines the current injected into the motor during DC braking.
P4.10	Stop DC current time	0,00	600,00	s	0,00	508	Determines if braking is ON or OFF and the braking time of the DC-brake when the motor is stopping. 0 = Not active
P4.11	Stop DC current frequency	0,10	10,00	Hz	1,50	515	The output frequency at which the DC-braking is applied.
P4.12	Start DC current time	0,00	600,00	s	0,00	516	0 = Not active
P4.13	Accel2 Frequency Threshold	0,00	P3.2	Hz	0,00	527	0,00 = disabled
P4.14	Decel2 Frequency Threshold	0,00	P3.2	Hz	0,00	528	0,00 = disabled
P4.15	External Brake: Open Delay	0,00	320,00	s	0,20	1544	

Table 9: Ramps and brakes setup

Code	Parameter	Min	Max	Unit	Default	ID	Note
P4.16	External Brake: Open Frequency limit	0,00	P3.2	Hz	1,50	1535	
P4.17	External Brake : Close Frequency limit	0,00	P3.2	Hz	1,00	1539	
P4.18	External Brake : Close Frequency limit in Reverse	0,00	P3.2	Hz	1,50	1540	
P4.19	External Brake : Open/Close Cur- rent limit	0,0	200,0	%	20,0	1585	

Table 9: Ramps and brakes setup

5.7 Digital inputs (Control panel: Menu PAR -> P5)

Code	Parameter	Min	Max	Unit	Default	ID	Note
P5.1	I / O control signal 1	0	6		1	403	0 = Not used 1 = DI1 2 = DI2 3 = DI3 4 = DI4 5 = DI5 6 = DI6
P5.2	I / O control signal 2	0	6		2	404	As parameter 5.1
P5.3	Reverse	0	6		0	412	As parameter 5.1
P5.4	Ext. fault Close	0	6		6	405	As parameter 5.1
P5.5	Ext. fault Open	0	6		0	406	As parameter 5.1
P5.6	Fault reset	0	6		3	414	As parameter 5.1
P5.7	Run enable	0	6		0	407	As parameter 5.1
P5.8	Preset speed B0	0	6		4	419	As parameter 5.1
P5.9	Preset speed B1	0	6		5	420	As parameter 5.1
P5.10	Preset speed B2	0	6		0	421	As parameter 5.1
P5.11	Ramp time 2 selection	0	6		0	408	As parameter 5.1
P5.12	Motor potentiometer up	0	6		0	418	As parameter 5.1
P5.13	Motor potentiometer down	0	6		0	417	As parameter 5.1
P5.14	Remote control place 2	0	6		0	425	Activates control place 2 As parameter 5.1
P5.15	Remote control place freq reference 2	0	6		0	343	Activates control place 2 See parameter 5.1
P5.16	PID setpoint 2	0	6		0	1047	Activates reference 2 As parameter 5.1
P5.17	Motor PreHeat Active	0	6		0	1044	Activates the Motor Pre-Heat (DC-Current) in stop state when parameter Motor Preheat function is set to 2 As parameter 5.1

Table 10: Digital inputs

5.8 Analogue inputs (Control panel: Menu PAR -> P6)

Code	Parameter	Min	Max	Unit	Default	ID	Note
P6.1	AI1 Signal range	0	1		0	379	0 = 0 - 100% (0 - 10 V) 1 = 20% - 100% (2 - 10 V)
P6.2	AI1 Custom min	-100,00	100,00	%	0,00	380	0,00 = no min scaling
P6.3	AI1 Custom max	-100,00	300,00	%	100,00	381	100,00 = no max scaling
P6.4	AI1 filter time	0,0	10,0	s	0,1	378	0 = no filtering
P6.5	AI2 signal range	0	1		0	390	0 = 0 - 10 V / 0 - 20 mA 1 = 2 - 10 V / 4 - 20 mA
P6.6	AI2 Custom min	-100,00	100,00	%	0,00	391	0,00 = no min scaling
P6.7	AI2 Custom max	-100,00	300,00	%	100,00	392	100,00 = no max scaling
P6.8	AI2 filter time	0,0	10,0	s	0,1	389	0 = no filtering

Table 11: Analogue inputs

5.9 Pulse train / Encoder (Control panel: Menu PAR -> P7)

Code	Parameter	Min	Max	Unit	Default	ID	Note
P7.1	Min pulse frequency	0	10000	Hz	0	1229	Pulse frequency to be interpreted as a 0% signal.
P7.2	Max pulse frequency	0,0	10000	Hz	10000	1230	Pulse frequency to be interpreted as a 100% signal.
P7.3	Freq. ref. at min pulse freq.	0,00	P3.2	Hz	0,00	1231	Frequency corresponding to 0% if used as frequency reference.
P7.4	Freq. ref. at max pulse freq.	0,00	P3.2	Hz	50,00 / 60,00	1232	Frequency corresponding to 100% if used as frequency reference.
P7.5	Encoder direction	0	2		0	1233	0 = Disable 1 = Enable / Normal 2 = Enable / Inverted
P7.6	Encoder pulses / revolution	1	65535	ppr	256	629	Pulse count of encoder per round. Used for scaling encoder rpm monitor value only.
P7.7	Config DI5 and DI6	0	2		0	1800	0 = DI5 and DI6 are for normal digital input 1 = DI6 is for pulse train 2 = DI5 and DI6 are for encoder frequency mode

Table 12: Pulse train/Encoder

5.10 Digital outputs (Control panel: Menu PAR -> P8)

Code	Parameter	Min	Max	Unit	Default	ID	Selections
P8.1	RO1 signal selection	0	19		2	313	0 = Not used 1 = Ready 2 = Run 3 = Fault 4 = Fault Inverted 5 = Warning 6 = Reversed 7 = At Speed 8 = Motor regulator active 9 = FB Control Word.B13 10 = FB Control Word.B14 11 = FB Control Word.B15 12 = Output freq superv. 13 = Output torque superv. 14 = Unit temperature superv. 15 = Analogue input superv. 16 = Preset Speed Active 17 = External Brake ctrl 18 = Keypad control active 19 = I / O control active
P8.2	RO2 signal selection	0	19		3	314	As parameter 8.1
P8.3	DO1 signal selection	0	19		1	312	As parameter 8.1
P8.4	RO2 inversion	0	1		0	489	0 = No inversion 1 = Inverted
P8.5	RO2 ON delay	0,00	320,00	s	0,00	460	0,00 = No delay
P8.6	RO2 OFF delay	0,00	320,00	s	0,00	461	0,00 = No delay
P8.7	RO1 inversion	0	1		0	1587	0 = No inversion 1 = Inverted
P8.8	RO1 ON delay	0,00	320,00	s	0,00	458	0,00 = No delay
P8.9	RO1 OFF delay	0,00	320,00	s	0,00	459	0,00 = No delay
P8.10	RO3 signal selection	0	19		0	317	As parameter 8.1, RO3-RO5 implemented but hidden until an option board is connected.
P8.11	RO4 signal selection	0	19		0	318	
P8.12	RO5 signal selection	0	19		0	1386	

Table 13: Digital outputs

5.11 Analogue outputs (Control panel: Menu PAR -> P9)

Code	Parameter	Min	Max	Unit	Default	ID	Selections
P9.1	Analog output signal selection	0	14		1	307	0 = Not used 1 = Output freq. (0-f _{max}) 2 = Output current (0-I _{nMotor}) 3 = Motor torque (0-T _{nMotor}) 4 = PID output (0 - 100%) 5 = Freq. refer. (0-f _{max}) 6 = Motor speed (0-n _{max}) 7 = Motor power (0-P _{nMotor}) 8 = Motor Voltage (0-U _{nMotor}) 9 = DC-link Voltage (0 - 1000 V) 10 = Process Data In1 (0 - 10000) 11 = Process Data In2 (0 - 10000) 12 = Process Data In3 (0 - 10000) 13 = Process Data In4 (0 - 10000) 14 = Test 100%
P9.2	Analog output minimum	0	1		0	310	0 = 0 V / 0 mA 1 = 2 V / 4 mA
P9.3	Analog output scaling	0,0	1000,0	%	100,0	311	Scaling factor
P9.4	Analog output filter time	0,00	10,00	s	0,10	308	Filter time
P9.5	Analog output 2 signal selection	0	14		1	472	As parameter 9.1, A02&A03 implemented but hidden until an option board is connected.
P9.6	Analog output 2 minimum	0	1		0	475	As parameter 9.2, A02&A03 implemented but hidden until an option board is connected.
P9.7	Analog output 2 scaling	0,0	1000,0	%	100,0	476	As parameter 9.3, A02&A03 implemented but hidden until an option board is connected.
P9.8	Analog output filter time	0,00	10,00	s	0,10	473	As parameter 9.4, A02&A03 implemented but hidden until an option board is connected.

Table 14: Analogue outputs

Code	Parameter	Min	Max	Unit	Default	ID	Selections
P9.9	Analog output 3 signal selection	0	14		1	479	As parameter 9.5
P9.10	Analog output 3 minimum	0	1		0	482	As parameter 9.6
P9.11	Analog output 3 scaling	0,0	1000,0	%	100,0	483	As parameter 9.7
P9.12	Analog output 3 filter time	0,00	10,00	s	0,10	480	As parameter 9.8

Table 14: Analogue outputs

5.12 Fieldbus Data-Mapping (Control panel: Menu PAR -> P10)

Code	Parameter	Min	Max	Unit	Default	ID	Note
P10.1	FB Data Output 1 selection	0	15		0	852	0 = Frequency reference 1 = Output reference 2 = Motor speed 3 = Motor current 4 = Motor voltage 5 = Motor torque 6 = Motor power 7 = DC link voltage 8 = Active fault code 9 = Analogue AI1 10 = Analogue AI2 11 = Digital input state 12 = PID feedback value 13 = PID setpoint 14 = Pulse train / encoder input(%) 15 = Pulse train / encoder pulse()
P10.2	FB Data Output 2 selection	0	15		1	853	Variable mapped on PD2
P10.3	FB Data Output 3 selection	0	15		2	854	Variable mapped on PD3
P10.4	FB Data Output 4 selection	0	15		4	855	Variable mapped on PD4
P10.5	FB Data Output 5 selection	0	15		5	856	Variable mapped on PD5
P10.6	FB Data Output 6 selection	0	15		3	857	Variable mapped on PD6
P10.7	FB Data Output 7 selection	0	15		6	858	Variable mapped on PD7
P10.8	FB Data Output 8 selection	0	15		7	859	Variable mapped on PD8
P10.9	Aux CW Data In selection	0	5		0	1519	PDI for Aux CW 0 = Not used 1 = PDI1 2 = PDI2 3 = PDI3 4 = PDI4 5 = PDI5

Table 15: Fieldbus Data-Mapping

5.13 Prohibited Frequencies (Control panel: Menu PAR -> P11)

Code	Parameter	Min	Max	Unit	Default	ID	Note
P11.1	Prohibit Frequency Range 1 Low Limit	0,00	P3.2	Hz	0,00	509	Low Limit 0 = Not used
P11.2	Prohibit Frequency Range 1 High Limit	0,00	P3.2	Hz	0,00	510	High Limit 0 = Not used
P11.3	Prohibit Frequency Range 2 Low Limit	0,00	P3.2	Hz	0,00	511	Low Limit 0 = Not used
P11.4	Prohibit Frequency Range 2 High Limit	0,00	P3.2	Hz	0,00	512	High Limit 0 = Not used

Table 16: Prohibited Frequencies

5.14 Limit Supervisions (Control panel: Menu PAR -> P12)

Code	Parameter	Min	Max	Unit	Default	ID	Note
P12.1	Output freq. supervision function	0	2		0	315	0 = Not used 1 = Low limit 2 = High limit
P12.2	Output freq. supervision limit	0,00	P3.2	Hz	0,00	316	Output frequency supervision threshold
P12.3	Torque supervision function	0	2		0	348	0 = Not used 1 = Low limit 2 = High limit
P12.4	Torque supervision limit	0,0	300,0	%	0,0	349	Torque supervision Threshold
P12.5	Unit Temperature Supervision	0	2		0	354	0 = Not used 1 = Low limit 2 = High limit
P12.6	Unit Temperature Supervision Limit	-10	100	°C	40	355	Unit temperature supervision threshold
P12.7	Analogue input superv signal	0	1		0	356	0 = AI1 1 = AI2
P12.8	AI superv ON level	0,00	100,00	%	80,00	357	ON threshold AI superv.
P12.9	AI superv OFF level	0,00	100,00	%	40,00	358	OFF threshold AI superv.

Table 17: Limit Supervisions

5.15 Protections (Control panel: Menu PAR -> P13)

Code	Parameter	Min	Max	Unit	Default	ID	Note
P13.1	Analog Input low fault	0	4		1	700	0 = No action 1 = Alarm 2 = Alarm, preset alarm frequency 3 = Fault: Stop function 4 = Fault: Coast
P13.2	Under voltage fault	1	2		2	727	1 = No response (no fault generated but drive still stops modulation) 2 = Fault:Coast
P13.3	Earth fault	0	3		2	703	0 = No action 1 = Alarm 2 = Fault:Stop function 3 = Fault:Coast
P13.4	Output Phase Fault	0	3		2	702	As parameter 13.3
P13.5	Stall protection	0	3		0	709	As parameter 13.3
P13.6	Under load protection	0	3		0	713	As parameter 13.3
P13.7	Motor thermal protection	0	3		2	704	As parameter 13.3
P13.8	Mtp:Ambient temperature	-20	100	°C	40	705	Environment temperature
P13.9	Mtp:Zero speed cooling	0,0	150,0	%	40,0	706	Cooling as % at 0 speed
P13.10	Mtp:Thermal time constant	1	200	min	Varies	707	Motor thermal time constant
P13.11	Stall Current	0,00	2,0 x I _{Nunit}	A	I _{Nunit}	710	
P13.12	Stall time	0,00	300,00	s	15,00	711	Stall time limited
P13.13	Stall frequency	0,10	320,00	Hz	25,00	712	Stall min. frequency
P13.14	UL:Field weakening load	10,0	150,0	%	50,0	714	Minimum torque at field weakening
P13.15	UL:Zero freq load	5,0	150,0	%	10,0	715	Minimum torque at F0
P13.16	UL:Time limit	1,0	300,0	s	20,0	716	
P13.17	Analog Input low fault delay	0,0	10,0	s	0,5	1430	

Table 18: Protections

Code	Parameter	Min	Max	Unit	Default	ID	Note
P13.18	External fault	0	3		2	701	0 = No action 1 = Alarm 2 = Fault: Stop function 3 = Fault: Coast
P13.19	Fieldbus fault	0	4		3	733	As parameter 13.1
P13.20	Preset alarm frequency	P3.1	P3.2	Hz	25,00	183	Frequency used when fault response is Alarm + preset Frequency.
P13.21	Parameters edit lock	0	1		0	819	0 = Edit enabled 1 = Edit disabled
P13.22	Thermistor Fault	0	3		2	732	0 = No action 1 = Alarm 2 = Fault: Stop function 3 = Fault: Coast Hidden until an option board is connected

Table 18: Protections

NOTE! These parameters are shown, when P17.2 = 0.

5.16 Fault autoreset parameters (Control panel: Menu PAR -> P14)

Code	Parameter	Min	Max	Unit	Default	ID	Note
P14.1	Automatic Reset	0	1		0	731	0 = Disabled 1 = Enable
P14.2	Wait time	0,10	10,00	s	0,50	717	Waiting time after fault
P14.3	Trial time	0,00	60,00	s	30,00	718	Maximum time for trials
P14.4	Trials number	1	10		3	759	Maximum trials
P14.5	Restart Function	0	2		2	719	0 = Ramping 1 = Flying 2 = From Start Function

Table 19: Fault autoreset parameters

NOTE! These parameters are shown, when P17.2 = 0.

5.17 PID control parameters (Control panel: Menu PAR -> P15)

Code	Parameter	Min	Max	Unit	Default	ID	Note
P15.1	Setpoint selection	0	7		0	332	0 = Fixed setpoint % 1 = AI1 2 = AI2 3 = ProcessDataIn1 (0 - 100%) 4 = ProcessDataIn2 (0 - 100%) 5 = ProcessDataIn3 (0 - 100%) 6 = ProcessDataIn4 (0 - 100%) 7 = Pulse train/encoder
P15.2	Fixed setpoint 1	0,0	100,0	%	50,0	167	Fixed setpoint
P15.3	Fixed setpoint 2	0,0	100,0	%	50,0	168	Alternative fixed setpoint, selectable with DI
P15.4	Feedback value selection	0	7		1	334	0 = AI1 1 = AI2 2 = ProcessDataIn1 (0 - 100%) 3 = ProcessDataIn2 (0 - 100%) 4 = ProcessDataIn3 (0 - 100%) 5 = ProcessDataIn4 (0 - 100%) 6 = AI2-AI1 7 = Pulse train / encoder
P15.5	Feedback value minimum	0,0	50,0	%	0,0	336	Value at minimum signal
P15.6	Feedback value maximum	10,0	300,0	%	100,0	337	Value at maximum signal
P15.7	P gain	0,0	1000,0	%	10,00	118	Proportional gain
P15.8	I time	0,00	320,00	s	10,00	119	Integrative time
P15.9	D time	0,00	10,00	s	0,00	132	Derivative time
P15.10	Error inversion	0	1		0	340	0 = Direct (Feedback < Setpoint -> Increase PID output) 1 = Inverted (Feedback > Setpoint -> Decrease PID output)

Table 20: PID control parameters

Code	Parameter	Min	Max	Unit	Default	ID	Note
P15.11	Sleep minimum frequency	0,00	P3.2	Hz	25,00	1016	Drive goes to sleep mode when the output frequency stays below this limit for a time greater than that defined by parameter Sleep delay
P15.12	Sleep delay	0	3600	s	30	1017	Delay for enter sleep
P15.13	Wake up error	0,0	100,0	%	5,0	1018	Threshold for exit sleep
P15.14	Sleep setpoint boost	0,0	50,0	%	10,0	1071	Referred to setpoint
P15.15	Setpoint boost time	0	60	s	10	1072	Boost time after P15.12
P15.16	Sleep maximum loss	0,0	50,0	%	5,0	1509	Referred to feedback value after boost
P15.17	Sleep loss check time	1	300	s	30	1511	After boost time P15.15
P15.18	Process display source select	0	6		0	1513	0 = PID feedback value 1 = Output frequency 2 = Motor speed 3 = Motor torque 4 = Motor power 5 = Motor current 6 = Pulse Train / Encoder
P15.19	Process display decimal digits	0	3		1	1035	Decimals on display
P15.20	Process display maximum value	0,0	3200,0		100,0	1034	Process max value

Table 20: PID control parameters

NOTE! These parameters are shown, when **P17.2 = 0**.

5.18 Motor Pre-heat (Control panel: Menu PAR -> P16)

Code	Parameter	Min	Max	Unit	Default	ID	Note
P16.1	Motor Pre-heat Function	0	2		0	1225	0 = Not used 1 = Always in stop state 2 = Controlled by digital input
P16.2	Motor Pre-heat Current	0	0,5 x I _{Nunit}	A	0	1227	DC current for Pre-heating of motor and drive in stop state. Active in stop state or by digital input while in stop state.

Table 21: Motor Pre-heat

5.19 Easy usage menu (Control panel: Menu PAR -> P17)

Code	Parameter	Min	Max	Unit	Default	ID	Note
P17.1	Application Type	0	3		0	540	0 = Basic 1 = Pump 2 = Fan drive 3 = High Torque NOTE! Visible only when Startup wizard is active.
P17.2	Parameter conceal	0	1		1	115	0 = All parameters visible 1 = Only quick setup parameter group visible

Table 22: Easy usage menu parameters

5.20 System parameters

Code	Parameter	Min	Max	Default	ID	Note
Software information (MENU PAR -> V1)						
V1.1	API SW ID				2314	
V1.2	API SW version				835	
V1.3	Power SW ID				2315	
V1.4	Power SW version				834	
V1.5	Application ID				837	
V1.6	Application revision				838	
V1.7	System load				839	
When Modbus and no Option board has been installed the comm. Parameters are as follows						
V2.1	Communication status				808	Status of Modbus communication. Format: xx.yyy where xx = 0 - 64 (Number of error messages) yyy = 0 - 999 (Number of good messages)
P2.2	Fieldbus protocol	0	1	0	809	0 = Not used 1 = Modbus used
P2.3	Slave address	1	255	1	810	
P2.4	Baud rate	0	8	5	811	0 = 300 1 = 600 2 = 1200 3 = 2400 4 = 4800 5 = 9600 6 = 19200 7 = 38400 8 = 57800
P2.6	Parity type	0	2	0	813	0 = None 1 = Odd 2 = Even
P2.7	Communication time out	0	255	0	814	0 = Not used 1 = 1 sec 2 = 2 secs, etc
P2.8	Reset communication status	0	1	0	815	
When Canopen board has been installed the comm. Parameters are as follows						
V2.1	Canopen communication status				14004	

Table 23: System parameters

Code	Parameter	Min	Max	Default	ID	Note
P2.2	Canopen operation mode	1	2	1	14003	
P2.3	Canopen Node ID	1	127	1	14001	
P2.4	Canopen baud rate	1	8	6	14002	
When DeviceNet board has been installed the comm. Parameters are as follows						
V2.1	Communication status				14014	
P2.2	Output assembly type	20	111	21	14012	
P2.3	MAC ID	0	63	63	14010	
P2.4	Baud rate	1	3	1	14011	
P2.5	Input assembly type	70	117	71	14013	
When ProfidBus board has been installed the comm. Parameters are as follows						
V2.1	Communication status				14022	
V2.2	Fieldbus protocol				14023	
V2.3	Active protocol				14024	
V2.4	Active buad rate				14025	
V2.5	Telegram type				14027	
P2.6	Operate mode	1	3	1	14021	
P2.7	Slave address	2	126	126	14020	
Other information						
V3.1	MWh counter				827	
V3.2	Power on days				828	
V3.3	Power on hours				829	
V3.4	Run counter: Days				840	
V3.5	Run counter: Hours				841	
V3.6	Fault counter				842	
V3.7	Panel parameter set status monitor					Hidden when connect with PC.
P4.2	Restore factory defaults	0	1	0	831	1 = Restores factory defaults for all parameters
P4.3	Password	0000	9999	0000	832	
P4.4	Time for panel and lcd backlight active	0	99	5	833	
P4.5	Save parameter set to panel	0	1	0		Hidden when connect with PC.
P4.6	Restore parameter set from panel	0	1	0		Hidden when connect with PC.
F5.x	Active Fault menu					
F6.x	Fault History menu					

Table 23: System parameters

6. FAULT TRACING

Fault code	Fault name	Fault code	Fault name
1	Overcurrent	25	Microcontroller watchdog fault
2	Overvoltage	27	Back EMF protection
3	Earth fault	34	Internal bus communication
8	System fault	35	Application fault
9	Undervoltage	41	IGBT Overtemperature
11	Output phase fault	50	Analog input select 20% - 100% (selected signal range 4 to 20 mA or 2 to 10 V)
13	Frequency converter undertemperature	51	External fault
14	Frequency converter overtemperature	52	Door Panel fault
15	Motor stalled	53	Fieldbus fault
16	Motor overtemperature	54	Slot fault
17	Motor underload	55	Wrong run fault
22	EEPROM checksum fault	57	Identification fault

Table 24: Fault codes. See User Manual for detailed fault descriptions.

7. GENERAL DATA

Dimensions and weight	Frame	Height	Width	Depth (mm)	Weight (kg)
	MI1	157	66	98	0.5
	MI2	195	90	102	0.7
	MI3	262	100	109	1
	MI4	370	165	165	8
	MI5	414	165	202	10
Supply network	Networks	Vacon 20 (400 V) cannot be used with corner grounded networks			
	Short circuit current	Maximum short circuit current has to be < 50 kA, For MI4 without DC-choke, maximum short circuit current has to be < 2.3 kA, for MI5 without DC-choke, maximum short circuit current has to be < 3.8 kA.			
Motor connection	Output voltage	0 - U _{in}			
	Output current	Continuous rated current I _N at ambient temperature max. +50 °C (depends on the unit size), overload 1.5 x I _N max. 1 min / 10 min			
Ambient conditions	Ambient operating temperature	-10 °C (no frost)...+40 / 50 °C (depends on the unit size); rated load-ability I _N Side by side installation for MI1-3 it is always 40 °C; For IP21/ Nema1 option in MI1-3 the maximum temperture is also 40 °C.			
	Storage temperature	-40 °C...+70 °C			
	Relative humidity	0..95% RH, non-condensing, non-corrosive, no dripping water			
	Altitude	100% load capacity (no derating) up to 1000 m. 1% derating for each 100 m above 1000 m; max. 2000 m			
	Enclosure class	IP20 / IP21 / Nema1 for MI1-3, IP21 for MI4-5			
EMC	Pollution degree	PD2			
	Immunity	Complies with EN50082-1, -2, EN61800-3			
	Emissions(See detailed descriptions in User Manual)	230V: Complies with EMC cat C2; With an internal RFI filter. MI4/5 complies C2 with an optional DC choke & CM choke. 400V: Complies with EMC cat C2; With an internal RFI filter MI4/5 complies C2 with an optional DC choke & CM choke.			
Standards	For EMC: EN61800-3, For safety: UL508C, EN61800-5				
Certificates and manufacturer's declarations of conformity	For safety: CB, CE, UL, cUL, For EMC: CE, CB, c-tick (see unit nameplate for more detailed approvals)				

Both: No EMC emission protection (Vacon level N): Without RFI filter

Cable and fuse requirements (See detailed data in Vacon 20 User Manual at: Vacon website) 380 - 480 V, 3~ 208 - 240 V, 3~	Frame	Fuse (A)	Mains cable Cu (mm ²)	Terminal cable min-max (mm ²)		Control & relay
				Main	Earth	
	MI1	6	3*1.5+1.5	1.5-4		0.5-1.5
	MI2	10				
	MI3	20				
	MI4	20/25/40 (20 and 40 is only for 208 - 240 V, 3~)	3*6+6	1-10Cu	1-10	
	MI5	40	3*10+10	2.5-50 Cu / Al	2.5-35	
115 V, 1~	MI2	20	2*2.5+2.5	1.5-4		
	MI3	32	2*6+6			
208 - 240, 1~	MI1	10	2*1.5+1.5	1.5-6		
	MI2	20	2*2.5+2.5			
	MI3	32	2*6+6			
575V	MI3	6	3*1.5+1.5	1.5-4		
	MI3	10				
	MI3	20	3*2.5+2.5	1.5-6		

- With above-mentioned fuses, the drive can be connected to power supply the short circuit current of which is max. 50 kA
- Use cables with heat resistance of at least +70 °C.
- The fuses function also as cable overload protection.
- These instructions apply only to cases with one motor and one cable connection from the frequency converter to the motor.
- To fulfil standard EN61800-5-1, the protective conductor should be **at least 10 mm² Cu or 16 mm² Al**. Another possibility is to use an additional protective conductor of at least the same size as the original one.

Vacon 20 power ratings

Mains voltage 208 - 240 V, 50 / 60 Hz, 1~ series							
Freq. converter type	Rated loadability		Motor shaft power		Nominal input current [A]	Mechanical size	Weight (kg)
	100% contin. current I_N [A]	150% over-load current [A]	P [HP]	P [KW]			
0001	1.7	2.6	0.33	0.25	4.2	M11	0.55
0002	2.4	3.6	0.5	0.37	5.7	M11	0.55
0003	2.8	4.2	0.75	0.55	6.6	M11	0.55
0004	3.7	5.6	1	0.75	8.3	M12	0.55
0005	4.8	7.2	1.5	1.1	11.2	M12	0.7
0007	7	10.5	2	1.5	14.1	M12	0.7
0009*	9.6	14.4	3	2.2	22.1	M13	0.99

Table 25: Vacon 20 power ratings, 208 - 240 V

* The maximum ambient operating temperature of this drive is 40 °C!

Mains voltage 208 - 240 V, 50 / 60 Hz, 3~ series							
Freq. converter type	Rated loadability		Motor shaft power		Nominal input current [A]	Mechanical size	Weight (kg)
	100% contin. current I_N [A]	150% over-load current [A]	P HP	P [KW]			
0001	1.7	2.6	0.33	0.25	2.7	M11	0.55
0002	2.4	3.6	0.5	0.37	3.5	M11	0.55
0003	2.8	4.2	0.75	0.55	3.8	M11	0.55
0004	3.7	5.6	1	0.75	4.3	M12	0.7
0005	4.8	7.2	1.5	1.1	6.8	M12	0.7
0007*	7	10.5	2	1.5	8.4	M12	0.7
0011*	11	16.5	3	2.2	13.4	M13	0.99
0012	12.5	18.8	4	3	14.2	M14	9
0017	17.5	26.3	5	4	20.6	M14	9
0025	25	37.5	7.5	5.5	30.3	M14	9
0031	31	46.5	10	7.5	36.6	M15	11
0038	38	57	15	11	44.6	M15	11

Table 26: Vacon 20 power ratings, 208 - 240 V, 3~

*The maximum ambient operating temperature of this drive is +40°C !

Mains voltage 115 V, 50 / 60 Hz, 1~ series							
Freq. converter type	Rated loadability		Motor shaft power		Nominal input current [A]	Mechanical size	Weight (Kg)
	100% contin. current I_N [A]	150% over-load current [A]	P [HP]	P [KW]			
0001	1.7	2.6	0.33	0.25	9.2	MI2	0.7
0002	2.4	3.6	0.5	0.37	11.6	MI2	0.7
0003	2.8	4.2	0.75	0.55	12.4	MI2	0.7
0004	3.7	5.6	1	0.75	15	MI2	0.7
0005	4.8	7.2	1.5	1.1	16.5	MI3	0.99

Table 27: Vacon 20 power ratings, 115 V, 1~

Mains voltage 380 - 480 V, 50 / 60 Hz, 3~ series							
Freq. converter type	Rated loadability		Motor shaft power		Nominal input current [A]	Mechanical size	Weight (kg)
	100% contin. current I_N [A]	150% over-load current [A]	P [HP]	P [KW]			
0001	1.3	2	0.5	0.37	2.2	MI1	0.55
0002	1.9	2.9	0.75	0.55	2.8	MI1	0.55
0003	2.4	3.6	1	0.75	3.2	MI1	0.55
0004	3.3	5	1.5	1.1	4	MI2	0.7
0005	4.3	6.5	2	1.5	5.6	MI2	0.7
0006	5.6	8.4	3	2.2	7.3	MI2	0.7
0008	7.6	11.4	4	3	9.6	MI3	0.99
0009	9	13.5	5	4	11.5	MI3	0.99
0012	12	18	7.5	5.5	14.9	MI3	0.99
0016	16	24	10	7.5	17.1	MI4	9
0023	23	34.5	15	11	25.5	MI4	9
0031	31	46.5	20	15	33	MI5	11
0038	38	57	25	18.5	41.7	MI5	11

Table 28: Vacon 20 power ratings, 380 - 480 V

* The maximum ambient operating temperature of these drives is +50 °C

Mains voltage 575 V, 50 / 60 Hz, 3~ series							
Fre- quency converter type	Rated loadability		Motor shaft power		Nominal input current [A]	Mechanical size	Weight (kg)
	100% contin. current I_N [A]	150% over- load current [A]	P [HP]	P [kW]			
0002	1,7	2,6	1	0,75	2	M13	0,99
0003	2,7	4,2	2	1,5	3,6	M13	0,99
0004	3,9	5,9	3	2,2	5	M13	0,99
0006	6,1	9,2	5	3,7	7,6	M13	0,99
0009	9	13,5	7,5	5,5	10,4	M13	0,99

Table 29: Vacon 20 power ratings, 575 V

Note: The input currents are calculated values with 100 kVA line transformer supply.

Quick Modbus setup

1	A: Select Fieldbus as remote control place: P2.1 to1 – Fieldbus B: Set Modbus RTU protocol to "ON": S2.2 to 1 – Modbus
2	A. Set Control Word to "0" [2001] B. Set Control Word to "1" [2001] C. Frequency converter status is RUN D. Set Reference value to "5000" [50,00%] [2003] E. Actual Speed is 5000 [25.00 Hz if MinFreq is 0.00 Hz and MaxFreq is 50.00 Hz] F. Set Control Word to "0" [2001] G. Frequency converter status is STOP

VACON

DRIVEN BY DRIVES

