

ACT20P – Strain gauge transmitter for reading from load cells

ACT20P bridge – Strain gauge transmitter for reading from load cells

General

The ACT20P Bridge is a DIN rail mounted, signal conditioner for industrial measuring bridges. It provides a precise excitation voltage for the bridge, and converts the input measurement to an isolated current/voltage signal. Strain gauge transmitter are used for various measurements like weight, force, tension, pressure, torque, and deflection.

Bridge excitation supply

Voltage sense connections are provided so that the excitation voltage can be measured at the bridge. Known as 'remote sensing' this method compensates for cabling and contact resistance errors. It is recommended for all new installations or where an upgrade is possible. Remote sensing wiring requires three twisted pairs.

TARE adjustment

The installed strain gauge is normally subjected to an initial load independent of the measurement taken. The TARE connection allows you to correct for this initial loading by operating a switch. Alternatively there is a button on the front of the unit (under the front cover) that performs the same function. Press for two seconds to correct for the initial load (the 'CAL HI' LED will light for one second).

Gauge factor

Every strain gauge has a 'gauge factor' which gives the output voltage at full-scale for a one volt excitation voltage (given in mV/V). You multiply this by the bridge excitation voltage to get the output voltage when the gauge is fully loaded. For example, a load cell with 10V excitation and 2mV/V gauge factor will give 20mV when fully loaded. The meaning of a 20mV output depends on the type of the strain gauge. If it was designed to measure 0-1000Kg then 20mV indicates a 1000Kg load.

Setup

The ACT20P Bridge has internal switch settings that determine the excitation voltage (5V or 10V) and Input range limits. Select the appropriate settings from the table below. Once you have set the DIP switches, you simply calibrate the unit to the input and output range for your application.

Calibration

There are three options for calibrating the ACT20P Bridge:

- Bench calibrate using a bridge simulator (if you know the gauge factor)
- Calibrate on-site by loading the actual installed strain gauge
- Bench calibrates using a mV source (if you know the gauge factor).

For more information please read the manual from the web page: www.weidmueller.com

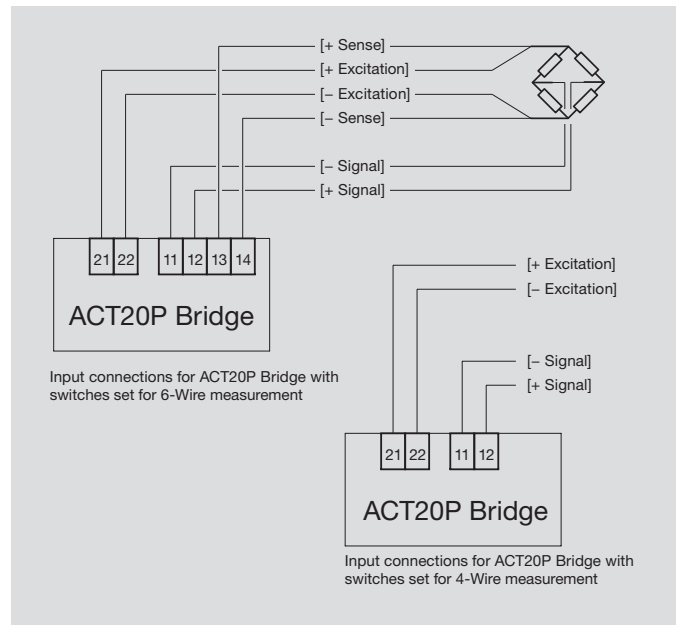

Configurable

Strain gauge transmitter for reading from load cells

- 3-way isolation
- Supply for measuring bridges up to 4 x 350 Ω
- Simple calibration of the tare weight using external switch or PLC input
- Input and output ranges adjustable via DIP switch

ACT20P-BRIDGE-S

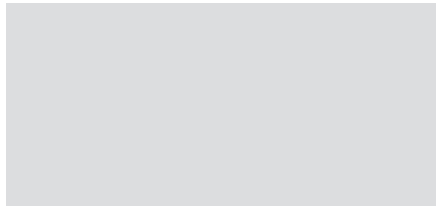
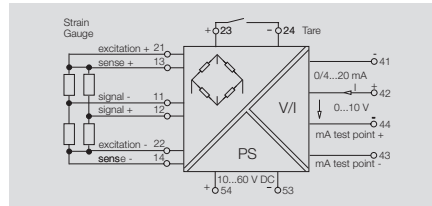

Technical data

Input	
Type	Resistance measuring bridge
Bridge sensitivity	1.0 mV / V to 5.0 mV / V
Input measurement range	± 10 mV / ± 20 mV / ± 30 mV / ± 50 mV (adjustable)
Input resistance	> 1 MΩ
Sensor supply	120 mA @ 10 V (= 4 x 350 Ω bridge resistors)
Bridge supply voltage	5 V or 10 V

Output	Voltage and current output (configurable)
Type	0 ...11 V (adjustable) / 0...22 mA (adjustable)
Output voltage / Output current	600 Ω / 1 kΩ

General data	
Supply voltage	10...60 V DC
Power consumption	3 W @ 24 V DC
Linearity	Typically ± 0.05% of signal range
Repeat accuracy	± 0.05% of signal range
Humidity	10...90 % (no condensation)
Temperature coefficient	typ. 0.005 % / °C
Long-term drift	0.1 % / 10,000 h
Step response time	< 400 ms (10...90 %)
Ambient temperature / Storage temperature	-40 °C...+70 °C / -40 °C...+85 °C
Approvals	cULus; CE

Insulation coordination	
Standards	EN 50178 (secure separation)
EMC standards	EN 61326
Rated voltage	300 V _{eff}
Impulse withstand voltage	4 kV (1.2/50 μs)
Pollution severity	2
Overvoltage category	III
Insulation voltage	5.7 kV (input / output, input / supply)

Dimensions	
Clamping range (nominal / min. / max.)	mm ²
Length x width x height	mm

Screw connection	
	2.5 / 0.5 / 2.5
	119.2 / 22.5 / 113.6

Note	

Note	

Ordering data	
	Screw connection

Type	Qty.	Order No.
ACT20P-BRIDGE-S	1	1067250000

Note	

Note	

Accessories	

Accessories	

Front panel DIP Switch settings

Switch	Action if On	Action if Off
1	10 V Excitation	5 V Excitation
2	mA Output	Voltage Output
3	10 mV Span	Turn off for other ranges
4	20 mV Span	
5	30 mV Span	
6	50 mV Span	
7	4-wire Measurement	6-wire Measurement
8		

Connections

Terminal	Signal	
11	Signal -	Input signal
12	Signal +	
13	Sense +	Bridge Excitation Voltage
14	Sense -	
21	Excitation +	External Tare switch
22	Excitation -	
23	Tare +	Output signal
24	Tare -	
41	mA Output -	Output signal
42	Output +	
43	mA Test Point -	Output signal
44	Voltage Output -	
44	mA Test Point +	Power Supply
54	+	
53	-	