

## 3-stage protection with screw connection

Surge protection terminals with the tried-and-tested screw connection in the DKU series are characterised by their high level of protection concentrated in a compact design.

They are suitable for installing in the narrowest of places in automated process, industrial and building services systems. The three-stage surge protection terminals operate with gas discharge tubes, varistors, suppression diodes (TAZ) or decoupling inductances. The gas discharge tubes discharge high currents reliably; the varistors and suppression diodes absorb the residual voltages. The rated current for the DK4U and DK5U is max. 300 mA and for the DK6U max. 1 A. The DKU series comprises the DKU, DK4U, DK5U and DK6U, which are 6, 8 or 12 mm wide.

Type **DK4U** contains individual components such as varistors, gas discharge tubes or suppression diodes. Two types of varistor (MOV) are used: Type S14 is intended for lower levels of interference. It is suitable for interference protection circuits in solenoid valves or switching contacts. Type S20 is reserved for more demanding situations.

The fine gradation of the voltage varistors permits the use of all conventional rated voltages. This results in a wide range of variations. The preferred types are varistors that are used for rated voltages of 24, 48, 115 and 230 V.

Two types of gas discharge tube are used: **Gas discharge tubes** (GDT) up to 10 kA are suitable for integrating into instrumentation and control circuits, those up to 20 kA for higher signal and mains voltages.

The **suppression diodes** (Tranzorb diodes) differ in terms of voltage and are suitable for discharging small and fast transients. The tightening torque for all DKU according to IEC 947 is 0.5 Nm.

### RC combinations

RC combinations can be used as suppression circuits for contactors and solenoid valves, or for increasing the interference immunity of long AC lines. They exhibit very good properties with regard to limiting the opening surges, reducing the rate of voltage variation and shortening break times. Weidmüller RC combinations may be used in both AC and DC circuits.

### RD combinations

RD combinations are used with DC-operated equipment. Compared to a diode circuit, the resistance of the resistor / diode combination results in a shorter recovery time. RD combinations exhibit excellent suppression effects because the resistance limits the flow of current and, as a result, the

switching times are shorter. RD combinations are also less expensive than RC combinations.

If the length of the recovery time of the connected device is irrelevant, a diode circuit is preferable. If the effect on the response times of the device to be connected are to be minimised, suppression combinations with varistors or RC combination are advantageous.

### WPO 4

The Weidmüller WPO 4 terminal enables the retrofitting of electronic components like diodes, RC combinations, varistors or gas discharge tubes. As the protective elements are simply plugged in, specific protective circuits can be set up inexpensively in situ. All components are likewise easy to replace.

DK 4 U Varistor gas discharge tube

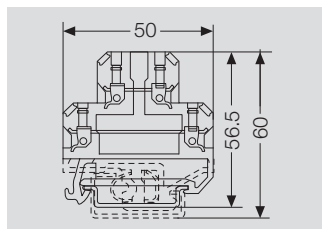

DK 4 U with suppression diode

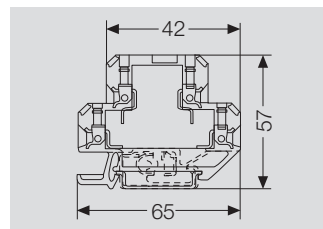

DK 5 U

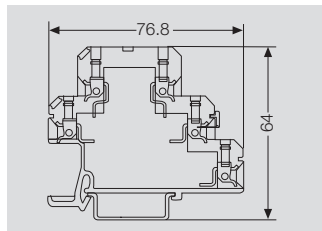

DKU with combination circuit

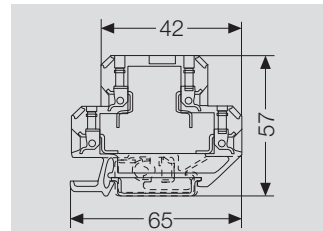

DK 6 U

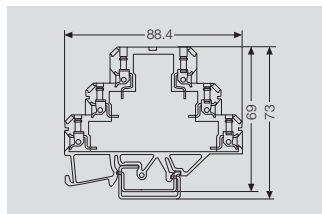

**DK series**

**3-stage protection with screw connection**

Slimline surge protection terminal with screw connection

**DKU 24 V DC 0.3 A**

Protection for binary signals



**DKU 48 V UC 0.3 A**

Protection for binary signals

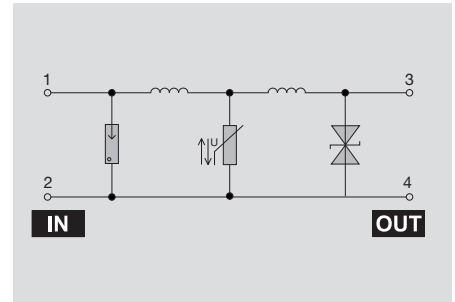
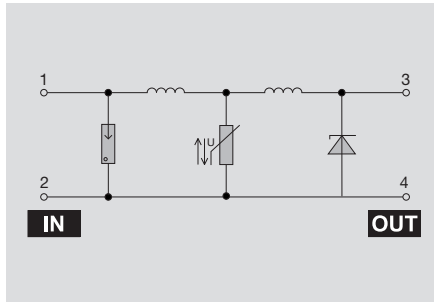

**Technical data**

Technical data	
Rated voltage (AC)	
Rated voltage (DC)	
max. continuous voltage, U <sub>c</sub> (AC)	
Operating current, I <sub>max</sub>	
Volume resistivity	
Gas discharge tube	
Varistor	
Suppression diodes	
Cut-off frequency (-3 dB) at load impedance	
Discharge current, max. (8/20 μs)	
Protection level on output side sym., input 1 kV/μs, typ.	
Protection level on output side sym., input 8/20 μs, typ.	
Protection level on output side unsym., input 1kV/μs, typ.	
Protection level on output side unsym., input 8/20 μs, typ.	
Design	
Type of connection	
Ambient temperature (operational)	
Storage temperature	

24 V
28 V
0.3 A
3.00 Ω
yes
yes
yes
500.0 kHz 240 Ω
5 kA
35 V
45 V
35 V
45 V
terminal
Screw connection
-25 ... 60°C
-25 ... 85°C

48 V
48 V
54 V
0.3 A
3.00 Ω
yes
yes
yes
1000.0 kHz 480 Ω
7 kA
82 V
110 V
82 V
180 V
terminal
Screw connection
-25 ... 60°C
-25 ... 85°C

**Type of connection**

Clamping range (rating- / min. / max.)	mm <sup>2</sup>	2.5 / 0.5 / 4
Length x width x height	mm	65 x 6 x 60

2.5 / 0.5 / 4	65 x 6 x 60
---------------	-------------

2.5 / 0.5 / 4	65 x 6 x 60
---------------	-------------

**Note**

**Ordering data**

Type	Qty.	Order No.
DKU 35 24VDC In:0,22A	10	8015810000

DKU 35 height 57mm
--------------------

Type	Qty.	Order No.
DKU 35 48VUC In:0,22A	10	8019290000

DKU 35 height 57mm

**Accessories**

<b>Note</b>	End plate AP DKT4 PA: 0687560000
-------------	-------------------------------------

End plate AP DKT4 PA: 0687560000
-------------------------------------

End plate AP DKT4 PA: 0687560000
-------------------------------------

### 3-stage protection with screw connection

Slimline surge protection terminal with screw connection

### DKU 115 V UC 0.3 A

Protection for binary signals



### DKU 230 V UC 0.3 A

Protection for binary signals

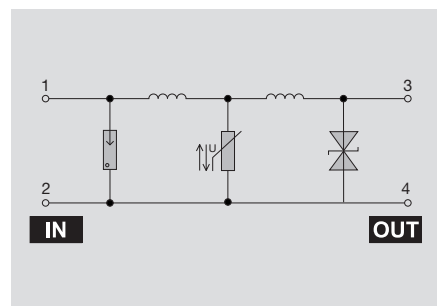
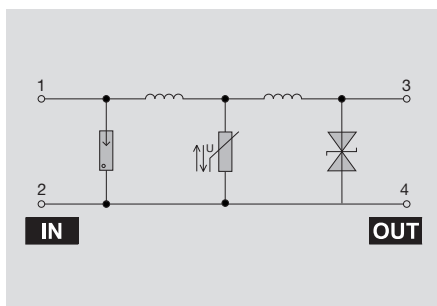

### Technical data

Technical data	
Rated voltage (AC)	115 V
Rated voltage (DC)	115 V
max. continuous voltage, U <sub>c</sub> (AC)	122 V
Operating current, I <sub>max</sub>	0.3 A
Volume resistivity	3.00 Ω
Gas discharge tube	yes
Varistor	yes
Suppression diodes	yes
Cut-off frequency (-3 dB) at load impedance	1.0 MHz 50 Ω
Discharge current, max. (8/20 μs)	7 kA
Protection level on output side sym., input 1 kV/μs, typ.	180 V
Protection level on output side sym., input 8/20 μs, typ.	220 V
Protection level on output side unsym., input 1kV/μs, typ.	180 V
Protection level on output side unsym., input 8/20 μs, typ.	220 V
Design	terminal
Type of connection	Screw connection
Ambient temperature (operational)	-25 ... 60°C
Storage temperature	-25 ... 85°C

Rated voltage (AC)	230 V
Rated voltage (DC)	230 V
max. continuous voltage, U <sub>c</sub> (AC)	240 V
Operating current, I <sub>max</sub>	0.3 A
Volume resistivity	3.00 Ω
Gas discharge tube	yes
Varistor	yes
Suppression diodes	yes
Cut-off frequency (-3 dB) at load impedance	1.0 MHz 2200Ω
Discharge current, max. (8/20 μs)	7 kA
Protection level on output side sym., input 1 kV/μs, typ.	400 V
Protection level on output side sym., input 8/20 μs, typ.	520 V
Protection level on output side unsym., input 1kV/μs, typ.	400 V
Protection level on output side unsym., input 8/20 μs, typ.	520 V
Design	terminal
Type of connection	Screw connection
Ambient temperature (operational)	-25 ... 60°C
Storage temperature	-25 ... 85°C

Rated voltage (AC)	230 V
Rated voltage (DC)	230 V
max. continuous voltage, U <sub>c</sub> (AC)	240 V
Operating current, I <sub>max</sub>	0.3 A
Volume resistivity	3.00 Ω
Gas discharge tube	yes
Varistor	yes
Suppression diodes	yes
Cut-off frequency (-3 dB) at load impedance	1.0 MHz 2200Ω
Discharge current, max. (8/20 μs)	7 kA
Protection level on output side sym., input 1 kV/μs, typ.	400 V
Protection level on output side sym., input 8/20 μs, typ.	520 V
Protection level on output side unsym., input 1kV/μs, typ.	400 V
Protection level on output side unsym., input 8/20 μs, typ.	520 V
Design	terminal
Type of connection	Screw connection
Ambient temperature (operational)	-25 ... 60°C
Storage temperature	-25 ... 85°C

### Type of connection

Clamping range (rating- / min. / max.)	mm <sup>2</sup>	2.5 / 0.5 / 4
Length x width x height	mm	65 x 6 x 60

Clamping range (rating- / min. / max.)	mm <sup>2</sup>	2.5 / 0.5 / 4
Length x width x height	mm	65 x 6 x 60

Clamping range (rating- / min. / max.)	mm <sup>2</sup>	2.5 / 0.5 / 4
Length x width x height	mm	65 x 12 x 60

### Note

### Ordering data

Type	Qty.	Order No.
DKU 35 115VUC 0,3A	10	8019310000

Type	Qty.	Order No.
DKU 35 115VUC 0,3A	10	8019310000

Type	Qty.	Order No.
DKU 35 230VUC 0,3A	10	8019330000

### Note

DKU 35 height 57mm

DKU 35 height 57mm

### Accessories

Note	End plate AP DKT4 PA: 0687560000
------	-------------------------------------

Note	End plate AP DKT4 PA: 0687560000
------	-------------------------------------

Note	End plate AP DKT4 PA: 0687560000
------	-------------------------------------

**DK series**

**3-stage protection with screw connection**

Slimline surge protection terminal with screw connection

**DKU DK5 24 V DC 0.3 A**

Protection for analogue signals



**DKU DK5 48 V UC 0.3 A**

Protection for analogue signals

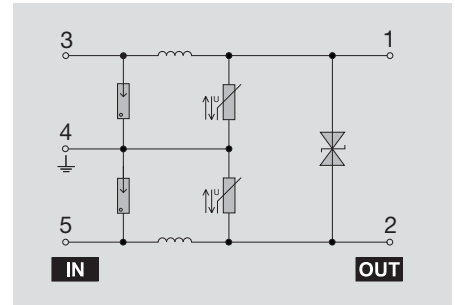
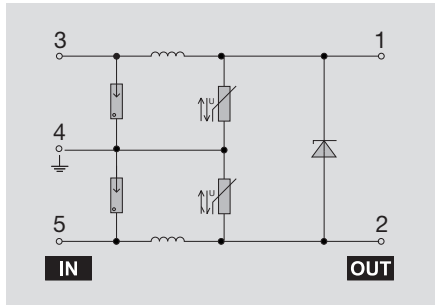
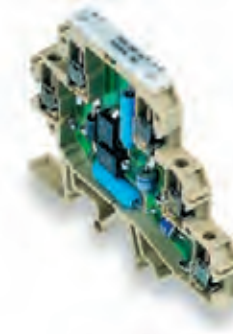

**Technical data**

**Technical data**

Rated voltage (AC)  
 Rated voltage (DC)  
 max. continuous voltage, U<sub>c</sub> (AC)  
 Operating current, I<sub>max</sub>  
 Volume resistivity  
 Gas discharge tube  
 Varistor  
 Suppression diodes  
 Cut-off frequency (-3 dB) at load impedance  
 Discharge current, max. (8/20 μs)  
 Protection level on output side sym., input 1 kV/μs, typ.  
 Protection level on output side sym., input 8/20 μs, typ.  
 Protection level on output side unsym., input 1kV/μs, typ.  
 Protection level on output side unsym., input 8/20 μs, typ.  
 Design  
 Type of connection  
 Ambient temperature (operational)  
 Storage temperature

24 V  
 28 V  
 0.3 A  
 3.00 Ω  
 yes  
 yes  
 yes  
 400.0 kHz 240 Ω  
 5 kA  
 30 V  
 45 V  
 35 V  
 45 V  
 terminal  
 Screw connection  
 -25 ... 60°C  
 -25 ... 85°C

48 V  
 48 V  
 54 V  
 0.3 A  
 3.00 Ω  
 yes  
 yes  
 yes  
 400.0 kHz 240 Ω  
 7 kA  
 82 V  
 110 V  
 110 V  
 180 V  
 terminal  
 Screw connection  
 -25 ... 60°C  
 -25 ... 85°C

**Type of connection**

Clamping range (rating- / min. / max.) mm<sup>2</sup>  
 Length x width x height mm

2.5 / 0.5 / 4  
 76.8 x 6 x 72

2.5 / 0.5 / 4  
 76.8 x 6 x 72

**Note**

**Ordering data**

Type	Qty.	Order No.
DKU DK5 24VDC 0,3A	10	8238340000
DKU DK5 TS35, 68 mm high		

Type	Qty.	Order No.
DKU DK5 48VUC 0,3A	10	8262470000
DKU DK5 TS35, 68 mm high		

**Note**

**Accessories**

**Note**

End plate  
 AP DK5 PA BE: 4036780000

End plate  
 AP DK5 PA BE: 4036780000

### 3-stage protection with screw connection

Slimline surge protection terminal with screw connection

### DKU DK6 120 V UC 1 A

Protection for analogue signals



### DKU DK6 230 V UC 1 A

Protection for analogue signals

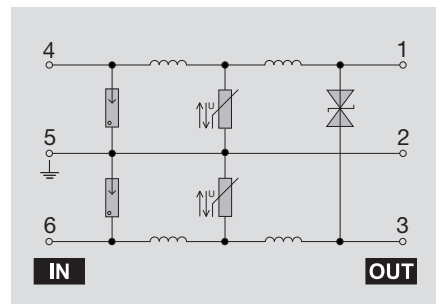
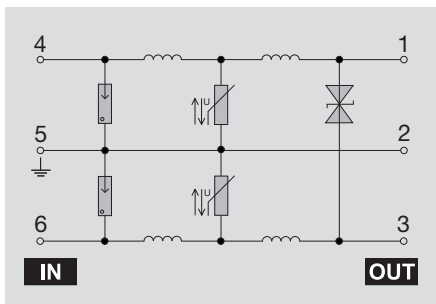

#### Technical data

Technical data	
Rated voltage (AC)	120 V
Rated voltage (DC)	120 V
max. continuous voltage, U <sub>c</sub> (AC)	130 V
Operating current, I <sub>max</sub>	1 A
Volume resistivity	0.30 Ω
Gas discharge tube	yes
Varistor	yes
Suppression diodes	yes
Cut-off frequency (-3 dB) at load impedance	22.0 kHz 120 Ω
Discharge current, max. (8/20 μs)	7 kA
Protection level on output side sym., input 1 kV/μs, typ.	220 V
Protection level on output side sym., input 8/20 μs, typ.	290 V
Protection level on output side unsym., input 1kV/μs, typ.	290 V
Protection level on output side unsym., input 8/20 μs, typ.	350 V
Design	terminal
Type of connection	Screw connection
Ambient temperature (operational)	-25 ... 60°C
Storage temperature	-25 ... 85°C

Rated voltage (AC)	120 V
Rated voltage (DC)	120 V
max. continuous voltage, U <sub>c</sub> (AC)	130 V
Operating current, I <sub>max</sub>	1 A
Volume resistivity	0.30 Ω
Gas discharge tube	yes
Varistor	yes
Suppression diodes	yes
Cut-off frequency (-3 dB) at load impedance	22.0 kHz 120 Ω
Discharge current, max. (8/20 μs)	7 kA
Protection level on output side sym., input 1 kV/μs, typ.	220 V
Protection level on output side sym., input 8/20 μs, typ.	290 V
Protection level on output side unsym., input 1kV/μs, typ.	290 V
Protection level on output side unsym., input 8/20 μs, typ.	350 V
Design	terminal
Type of connection	Screw connection
Ambient temperature (operational)	-25 ... 60°C
Storage temperature	-25 ... 85°C

Rated voltage (AC)	230 V
Rated voltage (DC)	230 V
max. continuous voltage, U <sub>c</sub> (AC)	240 V
Operating current, I <sub>max</sub>	1 A
Volume resistivity	0.30 Ω
Gas discharge tube	yes
Varistor	yes
Suppression diodes	yes
Cut-off frequency (-3 dB) at load impedance	22.0 kHz 120 Ω
Discharge current, max. (8/20 μs)	7 kA
Protection level on output side sym., input 1 kV/μs, typ.	600 V
Protection level on output side sym., input 8/20 μs, typ.	800 V
Protection level on output side unsym., input 1kV/μs, typ.	820 V
Protection level on output side unsym., input 8/20 μs, typ.	950 V
Design	terminal
Type of connection	Screw connection
Ambient temperature (operational)	-25 ... 60°C
Storage temperature	-25 ... 85°C

#### Type of connection

Clamping range (rating- / min. / max.)	mm <sup>2</sup>	2.5 / 0.5 / 4
Length x width x height	mm	88.4 x 8 x 73

Clamping range (rating- / min. / max.)	mm <sup>2</sup>	2.5 / 0.5 / 4
Length x width x height	mm	88.4 x 8 x 73

Clamping range (rating- / min. / max.)	mm <sup>2</sup>	2.5 / 0.5 / 4
Length x width x height	mm	88.4 x 8 x 73

#### Note

#### Ordering data

Type	Qty.	Order No.
DKU DK6 120VAC 1,0A	10	8262480000

Type	Qty.	Order No.
DKU DK6 120VAC 1,0A	10	8262480000

Type	Qty.	Order No.
DKU DK6 230VAC 1,0A	10	on demand

#### Note

DK6U TS35, 69 mm high

DK6U TS35, 69 mm high

#### Accessories

Note	End plate AP DK6 PA BE: 8324560000
------	---------------------------------------

Note	End plate AP DK6 PA BE: 8324560000
------	---------------------------------------

Note	End plate AP DK6 PA BE: 8324560000
------	---------------------------------------

**DK series**

**DK-SERIES with varistor in terminal design**

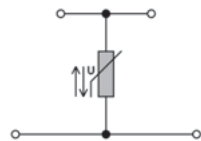

**Varistors**

Metal-oxide varistors are used as varistors. These are approved for the maximum sinusoidal operating AC voltage indicated on the component. Any voltage exceeding the indicated voltage is safely discharged. Varistors can be used for medium to large ratings.

**DK 4 U S 20 K 130**

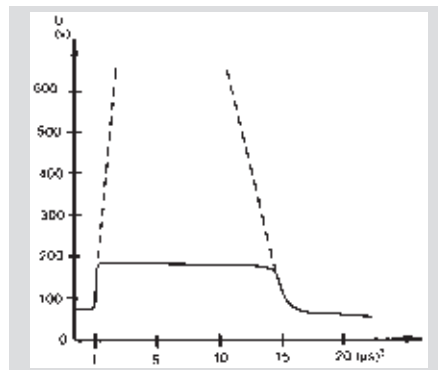

**Rated data DK 4 U**

Max. operating voltage at varistor	Max. energy and surge current for 8/20 μs impulse	Max. energy and surge current for 10 000 8/20 μs impulses	Max. varistor voltage at 10 A Disch. cur.	Max. varistor voltage at 1 mA
------------------------------------	---	---	---	-------------------------------

Type	U <sub>eff</sub>	U-	Energy	Surge cur.	Energy	Surge cur.	Capacity		Order No.	Order No.			
	V	V	J	A	J	A	pF	TS 32	TS 35				
S 14	11	14	1,6	1000	0,07	75	36	18	on request	9401400000			
	14	18	2,0	1000	0,08	75	42	22	on request	on request			
	17	22	2,7	1000	0,11	75	52	27	on request	on request			
	20	26	3,3	1000	0,13	75	65	33	on request	on request			
	25	31	3,7	1000	0,15	75	75	39	on request	9401440000			
	Preferred types 24 V		30	38	4,4	1000	0,17	75	90	47	5500	9401050000	9401450000
		35	45	5,2	1000	0,23	75	110	56	4500	on request	on request	
		40	56	6,8	1000	0,27	75	125	68	3300	on request	on request	
	Preferred types 48 V		50	65	27,0	4500	0,6	150	135	82	2900	on request	on request
		60	85	30,0	4500	0,7	150	155	100	2400	on request	9401490000	
Preferred types 115 V		75	100	38,0	4500	0,8	150	185	120	1900	on request	on request	
	95	125	45,0	4500	1,0	150	230	150	1500	on request	on request		
	130	170	55,0	4500	1,3	150	315	205	1000	9401120000	9401520000		
	140	180	60,0	4500	1,5	150	330	220	1000	on request	on request		
	150	200	65,0	4500	1,5	150	350	240	900	on request	on request		
	175	225	68,0	4500	1,6	150	420	270	750	on request	on request		
	230	300	85,0	4500	2,1	150	560	360	550	on request	on request		
	250	320	92,0	4500	2,4	150	610	390	500	on request	on request		
Preferred types 230 V		275	350	100,0	6500	2,5	190	660	430	450	9401180000	on request	
	300	385	110,0	6500	2,6	190	740	470	400	on request	9401590000		
S 20	11	14	3,0	2000	0,12	125	32	18	37000	on request	on request		
	14	18	4,0	2000	0,15	125	38	22	30000	on request	on request		
	17	22	5,6	2000	0,19	125	48	27	22000	on request	on request		
	20	26	6,6	2000	0,24	125	60	33	17000	on request	on request		
	25	31	7,8	2000	0,28	125	70	39	15000	on request	9401640000		
	Preferred types 24 V		30	38	9,0	2000	0,35	125	85	47	13000	9401250000	9401650000
		35	45	10,8	2000	0,40	125	100	56	11000	on request	on request	
		40	56	14,0	2000	0,48	125	120	68	7000	on request	on request	
	Preferred types 48 V		50	65	36,0	6500	0,5	190	120	82	5500	on request	on request
		60	85	45,0	6500	0,7	190	150	100	4800	on request	on request	
Preferred types 115 V		75	100	55,0	6500	0,8	190	180	120	3800	on request	on request	
	95	125	65,0	6500	1,0	190	220	150	3000	on request	on request		
	130	170	80,0	6500	1,4	190	300	205	2000	on request	on request		
	140	180	90,0	6500	1,5	190	320	220	2000	on request	on request		
	150	200	95,0	6500	1,6	190	340	240	1800	on request	on request		
	175	225	110,0	6500	1,8	190	390	270	1600	on request	on request		
	230	300	130,0	6500	2,4	190	550	360	1200	on request	on request		
	250	320	140,0	6500	2,7	190	600	390	1000	on request	on request		
Preferred types 230 V		275	350	150,0	8000	2,9	300	640	430	900	9401380000	9401780000	
	300	385	160,0	8000	3,0	300	700	470	900	on request	on request		

Overall width 12 mm



**DK 4 U with gas discharge tube or suppression diode**



The process depends on the temporal slew rate of the surge and the rated DC response voltage. The rated DC response voltage printed on the side of the gas discharge tube. Once the gas is ignited a typical arcing voltage of 10 to 30 V is produced across the component. The ionisation of the gas causes the gas discharge tube to become low resistive, allowing a high follow current to flow. Suitable measures must be taken to limit the follow current, for example, by fusing.

**Suppression diodes**

Suppression diodes work on a similar principle to conventional Zener diodes. If the indicated breakdown voltage is exceeded, the diode conducts. Compared to Zener diodes, suppression diodes have a higher current carrying capacity and faster response times in the ps range.

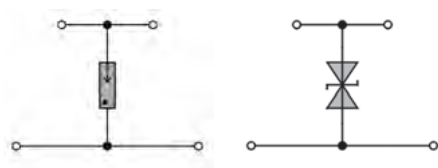

**DK 4 U gas discharge tube 5 kA, 90 V**

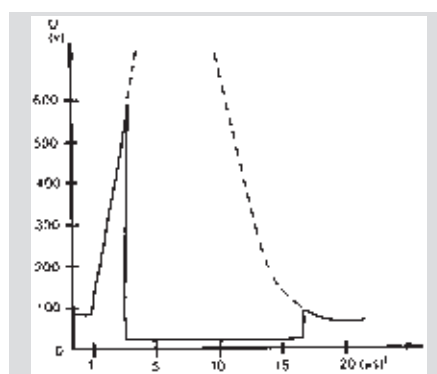

**Gas discharge tube**

The so-called gas discharge tube consists of two electrodes spaced a defined distance apart, enclosed in a small glass or ceramic tube. Between the electrodes is an inert gas at a defined pressure. A voltage surge, which has a rise time of 1 kV/μs and reaches a peak of 10 kV, can be limited to approx. 600 ... 700 V. The gas-filled space changes from high resistance to low resistance.

**Rated data DK 4 U**

Type		Rated DC sparkover voltage		Impulse sparkover voltage at 1 kV/μs	Maximum rated voltage		Capacity	Order No. TS 32	Order No. TS 35
		V	Tolerance %		V	U <sub>eff</sub> V			
10 kA (8/20 μs)	Preferred types 24 V	90 -	±25	< 600	35	50	≈2	on request	9400300000
	Preferred types 48 V	150 -	±15	< 600	60	90	≈2	on request	on request
		230 -	±20	< 600	95	135	≈2	on request	on request
20 kA (8/20 μs)									
	Preferred types 24 V	90 -	±25	< 600	35	50	≈2	9400400000	9400500000
		150 -	±15	< 600	60	90	≈2	on request	on request
	Preferred types 48 V	230 -	±15	< 650	95	135	≈2	on request	on request
	Preferred types 115 V	470 -	±15	<1000	200	280	≈2	on request	9400540000
	Preferred types 230 V	600 -	±15	<1000	255	360	≈2	on request	9400550000
DK 4 U with suppression diode		20 -	±10	< 60	-	28	≈3000	on request	8016960000
		48 AC	±10	< 146	53	74	≈1400	on request	on request
		115 AC	±10	< 300	135	178	≈700	on request	on request
		230 AC	±10	< 700	320	240	≈400	on request	8017020000
WDK 2,5 V with suppression diode		24 AC	±10	< 60	33 V	28 V	≈3000		8132760000

## DK series

### DK-SERIES with electronic components (other versions on request)



### DK 4 RC

Arc suppression circuit for contactors and solenoid valves (AC)  
Suppressor module for optos inputs



### DK 4 RC-VDR

Arc suppression circuit for contactors and solenoid valves (AC)

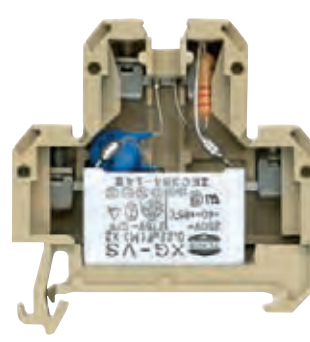

### Technical data

Dimensions DK 4/WDK 2.5	
Terminal width (+ fitting tolerance 0.2)	18 mm
Insulation stripping length	9 mm
Connection data	
Screw connection, flexible	DK 4
Screw connection, flexible	WDK 2.5
Wire cross-section	DK 4
Wire cross-section	WDK 2.5
VDE rated data	
Voltage	250 V~/300 V-
Diode current	-
Diode reverse voltage	-
Current of continuous current bar	10 A
Diode	-
Resistance	220 Ω
Capacitor	0,22 µF
Varistor (max. operating voltage)	-
Gas discharge tube (rated DC sparkover voltage)	-
max. discharge current (standard wave 8/20 µs)	-
Note	

18 mm
9 mm
0,5 ... 4 mm <sup>2</sup>
-
AWG 22 ... 12
-
250 V~/300 V-
-
-
10 A
-
220 Ω
0,22 µF
-
-
-

18 mm
9 mm
0,5 ... 4 mm <sup>2</sup>
-
AWG 22 ... 12
-
24 V~/250 V
-
-
10 A
10 A
-
-
47 Ω
47 Ω
0,22 µF
0,22 µF
S 14
S 14
50 V
250 V
-
-

### Ordering data

Version	
	for TS 32
	for TS 35
	for TS 35
Note	

Type	Order No.
DK 4 RC	0692160000
DK 4 RC/35	0053160000
WDK 2.5 RC	8065910000

Type	Varistor	Order No.
DK 4 RC-VRS	50 V	on request
DK 4 RC-VRS	50 V	on request
DK 4 RC-VRS/35	250 V	on request
DK 4 RC-VRS/35	250 V	on request

### Accessories

Mounting rail (2 m lengths)	
End bracket (thickness mm)	
End plate (thickness mm)	
Insulation plate	
Socket for test plug	
Test plug (pin diameter)	
Cross-connection (pre-assembled)	3-pole
	4-pole
	10-pole
Cover plate	
Fixing screw (plastic)	
Cross-connection bridge	2-pole
	3-pole
	4-pole
	75-pole
Insulation profile	
Note	

Type	Qty.	Order No.
TS 32	-	0122800000
TS 35	-	0383400000
EWK 1 (8.5)	50	0206160000
EW 35 (8.5)	50	0383560000
AP PA (1.5)	20	0359260000
TSch 4	100	0363360000
StB 8.5	50	0215700000
PS (ø 2.3)	20	0180400000
Q 4	50	0336600000
Q 10	20	0368600000
BSK M 2.5 x 18	100	0303300000
QB 2 <sup>1)</sup>	100	0482700000
QB 3 <sup>1)</sup>	50	0482800000
QB 4 <sup>1)</sup>	50	0482900000
QB 75 blank	10	0526400000
IP	-	0526700000
StB 8.5	50	0215700000

Type	Qty.	Order No.
TS 32	-	0122800000
TS 35	-	0383400000
EWK 1 (8.5)	50	0206160000
EW 35 (8.5)	50	0383560000
AP PA (1.5)	20	0359260000
TSch 4	100	0363360000
StB 8.5	50	0215700000
PS (ø 2.3)	20	0180400000
Q 4	50	0336600000
Q 10	20	0368600000
BSK M 2.5 x 18	100	0303300000
QB 2 <sup>1)</sup>	100	0482700000
QB 3 <sup>1)</sup>	50	0482800000
QB 4 <sup>1)</sup>	50	0482900000
QB 75 blank	10	0526400000
IP	-	0526700000

### DK 4 RD

Arc suppression circuit for contactor and solenoid valves (AC)



12 mm
9 mm
0,5 ... 4 mm <sup>2</sup>
-
AWG 22 ... 12
-
3 A
1300 V
10 A
BY 255
22 Ω (4 W)
-
-
-

Type	Order No.
DK 4 RD	on request
DK 4 RD/35	0059160000

Type	Qty.	Order No.
TS 32	-	0122800000
TS 35	-	0383400000
EWK 1 (8.5)	50	0206160000
EW 35 (8.5)	50	0383560000
AP PA (1.5)	20	0359260000
TSch 4	100	0363360000
StB 8.5	50	0215700000
PS (ø 2.3)	20	0180400000
Q 3	50	0336500000
Q 4	50	0336600000
Q 10	20	0368600000
AD 4 (4 terminals)	50	0303400000
BSK M 2.5 x 18	100	0303300000
QB 2')	100	0482700000
QB 3')	50	0482800000
QB 4')	50	0482900000
QB 75 blank	10	0526400000
IP	-	0526700000

### for retrofitting electronic components

WOP 4 with a pluggable varistor Weidmüller varistor terminals have been designed to allow the retrofitting of electronics components, e.g. varistors, diodes, gas discharge tubes, etc. These electronic terminals no longer have to be configured prior to installation and thus be delivered with soldered components which can no longer be distinguished.

The significant advantages of this new design are:

- Cost-savings
- Components can be changed quickly on site
- Service is limited to visual inspection
- Components are easy to distinguish
- Flexibility
- Components can immediately be adapted to changed conditions

### Technical data

Dimensions	
Width x length x height (mm) with TS 35x7.5 V	6/60/47
Insulation stripping length/clamping screw	9 mm/M 3
Rated data	
Rated voltage/current/cross-section	250 V/32 A/4 mm <sup>2</sup>
Rated impulse voltage VDE 0110/1.89/pollution severity	4 kV/3
Further technical data	
Tightening torque range	Nm 0,5...1,0
Torque setting with DMS2 electric screwdriver clamping range	2
"e" solid HO7V-U	mm <sup>2</sup> 0,5...4
"m" stranded HO7V-R	mm <sup>2</sup> 1,5...4
"f" flexible HO7V-K	mm <sup>2</sup> 0,5...4
"f" flexible HO7V-K and AEH DIN 46228/1	mm <sup>2</sup> 0,5...4
"f" flexible HO7V-K and AEH with plastic collar	mm <sup>2</sup> 0,5...4
Plug gauge to 947-1	Size A 3
Continuous current rating of terminal for wire size	32 A/4 mm <sup>2</sup>
Wire diameter of electrical components	mm 0,8...1,0
Note	

### Ordering data

Version	Qty.	Order No.
Wemid	50	1036000000
Intermediate frame		
Thickness 1.5 mm	20	1071100000
Busbar		
SSch 7.3x1.2	1m	1071200000
Varistors		
for 24 V		S14k30 on request
for 230 V		S14k275 on request
Gas discharge tube		
for 90 V		90 V 20 kA on request
for 600 V		600 V 20 kA on request
Note		

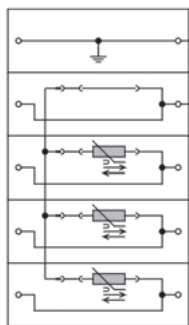

Surges in a three-phase supplies discharged to earth via WPE with the aid of varistors and a gas discharge tube.

### WPO 4

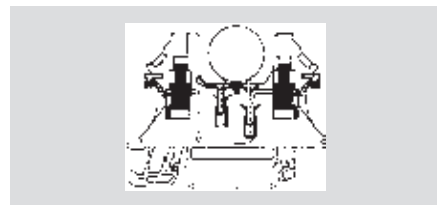
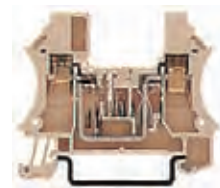

Type	Qty.	Order No.
ZR	20	1071100000
S14k30		on request
S14k275		on request
90 V 20 kA		on request
600 V 20 kA		on request
Note		

### Accessories

Marking tags	Type	Order No.
Print		
Consecutive horizontal	DEK6 FW	on request
Consecutive vertical	DEK6 FS	on request
Note		

**DKU**

Slimline surge protection terminals with ATEX approval

**DKU 24 V**

for TS 32 / TS 35



**DKU 48 V**

for TS 32 / TS 35

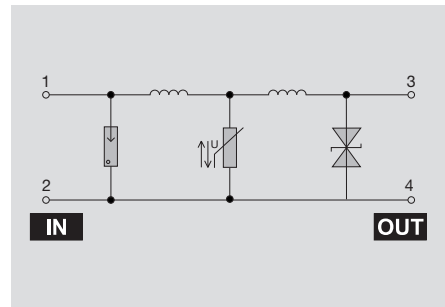
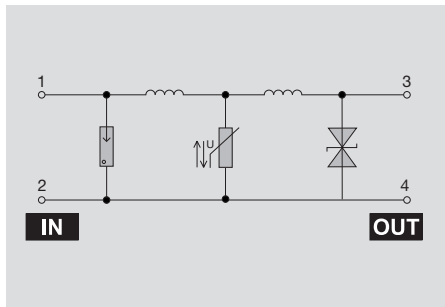

**Technical data**

Technical data	
DC voltage	28 V
Volume resistance 1/3	3,5 Ω
Rated current per path	0,22 A
Inductance of 4-pole network Li	0,2 mH
Capacitance of 4-pole network Ci	2,5 nF
Source impedance frequency response at 50 Ω/-3 dB	500 kHz at Ri = 240 Ω
∅Tú at 0,1 A and 60 °C ambient temperature, typical	18 K
Sparkover voltage of gas discharge tube at 1 kV/μs, typical	700 V
Interference voltage at output for 1 kV/μs at input, typical	33 V
Interference voltage at output for 8/20 μs and 2,5 kA at input, typical	38 V
max. leakage current to PE	10 μA
Ingress protection class	IP20
Circuit earthed for safety	yes
Operating temperature	-25 °C ... +60 °C
Clamping point with self-locking screw	yes
Approval	II 2 G EEx ia IIC T6 or II 2 D T85 °C IP6X
Registered design No.	TÜV 04 ATEX 2551 X

DC voltage	60 V
Volume resistance 1/3	3,5 Ω
Rated current per path	0,22 A
Inductance of 4-pole network Li	0,2 mH
Capacitance of 4-pole network Ci	1 nF
Source impedance frequency response at 50 Ω/-3 dB	1000 kHz at Ri = 480 Ω
∅Tú at 0,1 A and 60 °C ambient temperature, typical	11 K
Sparkover voltage of gas discharge tube at 1 kV/μs, typical	700 V
Interference voltage at output for 1 kV/μs at input, typical	82 V
Interference voltage at output for 8/20 μs and 2,5 kA at input, typical	100 V
max. leakage current to PE	10 μA
Ingress protection class	IP20
Circuit earthed for safety	yes
Operating temperature	-25 °C ... +60 °C
Clamping point with self-locking screw	yes
Approval	II 2 G EEx ia IIC T6 or II 2 D T85 °C IP6X
Registered design No.	TÜV 04 ATEX 2551 X

DC voltage	60 V
Volume resistance 1/3	3,5 Ω
Rated current per path	0,22 A
Inductance of 4-pole network Li	0,2 mH
Capacitance of 4-pole network Ci	1 nF
Source impedance frequency response at 50 Ω/-3 dB	1000 kHz at Ri = 480 Ω
∅Tú at 0,1 A and 60 °C ambient temperature, typical	11 K
Sparkover voltage of gas discharge tube at 1 kV/μs, typical	700 V
Interference voltage at output for 1 kV/μs at input, typical	82 V
Interference voltage at output for 8/20 μs and 2,5 kA at input, typical	100 V
max. leakage current to PE	10 μA
Ingress protection class	IP20
Circuit earthed for safety	yes
Operating temperature	-25 °C ... +60 °C
Clamping point with self-locking screw	yes
Approval	II 2 G EEx ia IIC T6 or II 2 D T85 °C IP6X
Registered design No.	TÜV 04 ATEX 2551 X

Connect the earth terminal to the equipotential bonding.  
When using the surge protection component in areas at risk of dust explosion, provide a housing that complies with class of protection IP 6X at least (to EN 60529) and also satisfies the conditions of EN 50281-1-1 points 4, 8 and 9.

Connect the earth terminal to the equipotential bonding.  
When using the surge protection component in areas at risk of dust explosion, provide a housing that complies with class of protection IP 6X at least (to EN 60529) and also satisfies the conditions of EN 50281-1-1 points 4, 8 and 9.

Note

**Ordering data**

Version	Type	Qty.	Order No.
TS 32	DKU 32 24 VDC 0,22 A		8015800000
TS 35	DKU 35 24 VDC 0,22 A		8015810000

Note

**Accessories**

Abschlussplatte AP DKT 4 PA	0687560000
-----------------------------	------------

Note

Version	Type	Qty.	Order No.
TS 32	DKU 32 48 VUC 0,22 A		8019280000
TS 35	DKU 35 48 VUC 0,22 A		8019290000

Note

Abschlussplatte AP DKT 4 PA	0687560000
-----------------------------	------------

Note

## Surge protection for instrumentation and control equipment with ATEX approval

### DKU slimline surge protection terminals

with ATEX approval

#### DKU 48 V

#### DKU 65 V

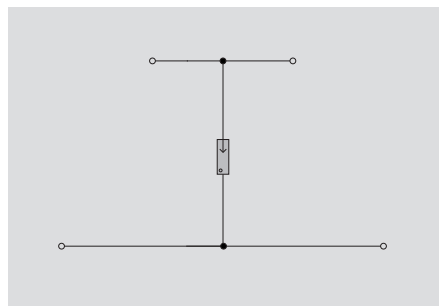
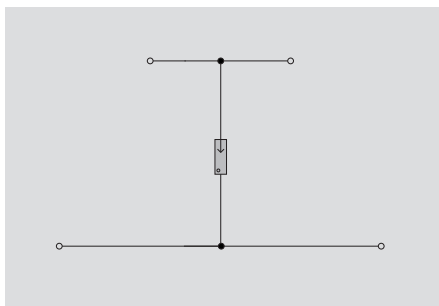
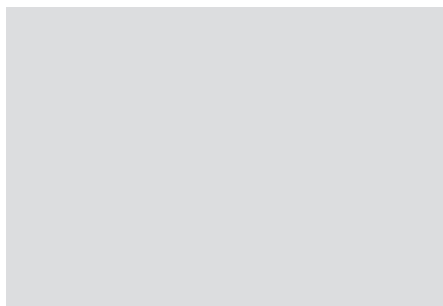

D



#### Technical data

Technical data	
DC voltage	48 V
Volume resistance 1/3	-
Rated current per path	0.5 A
Inductance of 4-pole network Li	-
Capacitance of 4-pole network Ci	-
Source impedance frequency response at 50 Ω/-3 dB	-
∅ Tü at 0.1 A and 60 °C ambient temperature, typical	< 15 K
Sparkover voltage of gas discharge tube at 1 kV/μs, typical	700 V
Interference voltage at output for 1 kV/μs at input, typical	700 V
Interference voltage at output for 8/20 μs and 2.5 kA at input, typical	800 V
max. leakage current to PE	1 μA
Ingress protection class	IP20
Circuit earthed for safety	-25 °C ... +85 °C
Operating temperature	-25 °C ... +60 °C
Circuit safety grounded	yes
Clamping point with self-locking screw	yes
Approval	II 2 G EEx ia IIC T6 or II 2 D T85 °C IP6X
Registered design No.	TÜV 04 ATEX 2551 X

DC voltage	48 V
Volume resistance 1/3	-
Rated current per path	0.5 A
Inductance of 4-pole network Li	-
Capacitance of 4-pole network Ci	-
Source impedance frequency response at 50 Ω/-3 dB	-
∅ Tü at 0.1 A and 60 °C ambient temperature, typical	< 15 K
Sparkover voltage of gas discharge tube at 1 kV/μs, typical	700 V
Interference voltage at output for 1 kV/μs at input, typical	700 V
Interference voltage at output for 8/20 μs and 2.5 kA at input, typical	800 V
max. leakage current to PE	1 μA
Ingress protection class	IP20
Circuit earthed for safety	-25 °C ... +85 °C
Operating temperature	-25 °C ... +60 °C
Circuit safety grounded	yes
Clamping point with self-locking screw	yes
Approval	II 2 G EEx ia IIC T6 or II 2 D T85 °C IP6X
Registered design No.	TÜV 04 ATEX 2551 X

DC voltage	65 V
Volume resistance 1/3	-
Rated current per path	0.5 A
Inductance of 4-pole network Li	-
Capacitance of 4-pole network Ci	-
Source impedance frequency response at 50 Ω/-3 dB	-
∅ Tü at 0.1 A and 60 °C ambient temperature, typical	< 15 K
Sparkover voltage of gas discharge tube at 1 kV/μs, typical	1100 V
Interference voltage at output for 1 kV/μs at input, typical	1100 V
Interference voltage at output for 8/20 μs and 2.5 kA at input, typical	1200 V
max. leakage current to PE	1 μA
Ingress protection class	IP20
Circuit earthed for safety	-25 °C ... +85 °C
Operating temperature	-25 °C ... +60 °C
Circuit safety grounded	no
Clamping point with self-locking screw	yes
Approval	II 2 G EEx ia IIC T6 or II 2 D T85 °C IP6X
Registered design No.	TÜV 04 ATEX 2551 X

Connect the earth terminal to the equipotential bonding.

When using the surge protection component in areas at risk of dust explosion, provide a housing that complies with class of protection IP 6X at least (to EN 60529) and also satisfies the conditions of EN 50281-1-1 points 4, 8 and 9.

Connect the earth terminal to the equipotential bonding.

When using the surge protection component in areas at risk of dust explosion, provide a housing that complies with class of protection IP 6X at least (to EN 60529) and also satisfies the conditions of EN 50281-1-1 points 4, 8 and 9.

Notes

Notes

Notes

#### Ordering data

Version

Type	Qty	Order No.
DK 4/35 U 90 V 20 kA		9400500000
DK 4/32 U 90 V 20 kA		9400400000

Type	Qty	Order No.
DK 4/35 U 470 V 20 kA		9400540000
DK 4/32 U 470 V 20 kA		on request

Notes

Notes

Notes

#### Accessories

Type	Qty	Order No.
AP DK4		0359260000

Type	Qty	Order No.
AP DK4		0359260000

Type	Qty	Order No.
AP DK4		0359260000

Notes

Notes

Notes

**DKU slimline surge protection**

with ATEX approval

**DKU DK 5 28 V**

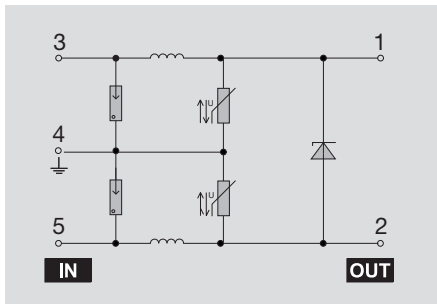

**Technical data**

Technical data	
DC voltage	28 V
Volume resistance 1/3	3,5 Ω
Rated current per path	0,3 A
Inductance of 4-pole network Li	0,2 mH
Capacitance of 4-pole network Ci	1,3 nF
Source impedance frequency response at 50 Ω/-3 dB	500 kHz at Ri = 240 Ω
∅ Tü at 0.1 A and 60 °C ambient temperature, typical	< 15 K
Sparkover voltage of gas discharge tube at 1 kV/μs, typical	700 V
Interference voltage at output for 1 kV/μs at input, typical	33 V
Interference voltage at output for 8/20 μs and 2.5 kA at input, typical	38 V
max. leakage current to PE	10 μA
Ingress protection class	IP20
Storage temperature	-25 °C ... +85 °C
Operating temperature	-25 °C ... +60 °C
Circuit earthed for safety	yes
Clamping point with self-locking screw	yes
Approval	II 2 G EEx ia IIC T6 or II 2 D T85 °C IP6X
Registered design No.	TÜV 04 ATEX 2551 X

DC voltage	28 V
Volume resistance 1/3	3,5 Ω
Rated current per path	0,3 A
Inductance of 4-pole network Li	0,2 mH
Capacitance of 4-pole network Ci	1,3 nF
Source impedance frequency response at 50 Ω/-3 dB	500 kHz at Ri = 240 Ω
∅ Tü at 0.1 A and 60 °C ambient temperature, typical	< 15 K
Sparkover voltage of gas discharge tube at 1 kV/μs, typical	700 V
Interference voltage at output for 1 kV/μs at input, typical	33 V
Interference voltage at output for 8/20 μs and 2.5 kA at input, typical	38 V
max. leakage current to PE	10 μA
Ingress protection class	IP20
Storage temperature	-25 °C ... +85 °C
Operating temperature	-25 °C ... +60 °C
Circuit earthed for safety	yes
Clamping point with self-locking screw	yes
Approval	II 2 G EEx ia IIC T6 or II 2 D T85 °C IP6X
Registered design No.	TÜV 04 ATEX 2551 X

Connect the earth terminal to the equipotential bonding.  
 When using the surge protection component in areas at risk of dust explosion, provide a housing that complies with class of protection IP 6X at least (to EN 60529) and also satisfies the conditions of EN 50281-1-1 points 4, 8 and 9.

**Notes**

**Ordering data**

Version

**Notes**

Type	Qty	Order No.
DKU DK5 24 VDC 100 MA		8437770000

**Accessories**

**Notes**

Type	Qty	Order No.
AP DK5		4036780000