







Catalog CA.VJ.01
VS mini, V1000 and V1000-4X Microdrives

Date: 07/01/10



Table of Contents

	Page	
	VS mini Drive	
	Description	3
	Standard Drives	5
	Dimensions and Data	6
	Dimension Drawing	7
	J1000 Drive (J1000)	
	Description	9
	Standard Drives	11
	Dimensions and Data	12
	Dimension Drawings	13
	Options	15
	V1000 Drive (V1000)	
	Description	23
	Standard Drives	25
	V1000 Drive Variants	26
	Dimensions and Data	28
	Dimension Drawings	29
	Options	33
	V1000-4X Drive (V1000-4X)	
	Description	43
	Standard Drives	45
	Dimensions and Data	46
	Dimension Drawings	47
	Options	51
Technical Training	53	
Terms and Conditions	54	

This catalog may describe trademarked equipment, which is the property of other companies. These trademarks are the property of the registered owner companies and may include the following:

DeviceNet™, trademark of ODVA.
Profibus®, trademark of PROFIBUS International
Modbus®, trademark of Schneider Automation, Inc.

Other Documents and Manuals are available to support special use or installation of this product. These documents may be provided with the product or upon request. Contact Yaskawa Electric America, Inc. or visit Yaskawa website, as required. Documents may include the following:

VS mini

TOE-S606-10.20C .. Technical Manual for VS mini Drive

J1000

TOEPC71060626.... J1000 Quick Start Guide
SIEPC71060631 J1000 Technical Manual
TM.J1000.01 J1000 Cheat Sheet
TOBPC73060032.... RS-232C Interface Technical Manual (SI-232/J and SI-232/JC)
TOBPC73060033.... RS-485 MEMOBUS/Modbus Interface Technical Manual (SI-485/J)
TOBPC73060034.... Potentiometer Technical Manual (AI-V3/J)
TOBPC73060035.... LED Operator Installation Manual (JVOP-182)
TOEPC73060020.... DriveWizard Plus Instruction Manual
TOBPC73060025.... USB Copy Unit (V-Stick) Technical Manual (JVOP-181)

V1000

TOEPC71060614.... V1000 Quick Start Guide
SIEPC71060618 V1000 Technical Manual
TM.V1000.01 V1000 Cheat Sheet
TOBPC73060023.... Profibus-DP Installation Manual (SI-P3/V)
SIEPC73060023 Profibus-DP Technical Manual (SI-P3/V)
TOBPC73060025.... USB Copy Unit (Y-Stick) Technical Manual (JVOP-181)
TOEPC73060028.... DeviceNet Installation Manual (SI-N3/V)
SIEPC73060028 DeviceNet Technical Manual (SI-N3/V)
TOEPC73060020.... DriveWizard Plus Instruction Manual
TOBPC73060029.... LCD Operator Installation Manual (JVOP-180)
TOBPC73060035.... LED Operator Installation Manual (JVOP-182)
TOEPYEACOM01 ... Ethernet/IP Installation Manual (SI-EN3/V)
SIEPYEACOM01 Ethernet/IP Technical Manual (SI-EN3/V)
TOEPYEACOM02... Modbus TCP/IP Installation Manual (SI-EM3/V)
SIEPYEACOM02 Modbus TCP/IP Technical Manual (SI-EM3/V)
TOBPC73060049.... MECHATROLINK-II Installation Manual (SI-T3/V)
SIEPC73060049 MECHATROLINK-II Technical Manual (SI-T3/V)
TOBPC73060027.... V1000 24V Control Power Unit
TOBPC71060621.... V1000 Finless Type Installation Guide
TOEPYEAOPT02.... 1000 Series Operator Mounting Kit NEMA Type 4X/IP66 Installation Manual
TOEPYEAOPT03.... V1000 120VAC Interface (D1-100)

V1000-4X

TOBPC71060635.... V1000-4X Installation Manual

Description

1/8 - 1HP

**VS
mini**



The VS mini drive is a full-featured, high-performance, "microsize" design. This significant size reduction has been accomplished without sacrificing the essential programming features of our larger drives.

The VS mini offers power and versatility for a wide range of applications including material handling, packaging, mixing, pumping, HVAC, commercial wash machines, recreation equipment (tread mills), overhead doors and general industrial applications. Available in both standard protected chassis and optional Din rail designs.

The "microsize" design features application-specific intelligent power module (ASIPM) devices and circuitry, a 16-bit microprocessor, surface-mounted devices for reliability and strength, and second generation insulated-gate bipolar transistor (IGBT) technology.

The VS mini is available in 1/8 through 1 HP, 115 VAC single-phase, 50/60 Hz models. Output is 3-phase, 0 to 230 VAC.

Performance Features

- Ratings: 1/8 to 1 HP at 115 VAC
- Constant torque overload rating: 150% for 1 min. (200% peak)
- DC injection braking, ramp to stop
- Electronic reversing
- Adjustable accel/decel: 0.1 to 999 sec
- Controlled speed range: 40:1
- Drive efficiency: 95%
- Displacement power factor: 0.98
- Output frequency: 0.1 to 400 Hz
- Output voltage: 0 to 230 VAC
- Frequency resolution:
0.1 Hz with digital reference
0.06 /60 Hz with analog reference
- Frequency accuracy (-10° to 50°C):
0.01% with digital command
0.1% with analog command
- Volts / hertz ratio: infinitely adjustable pattern
- DC injection braking: adjustable amplitude, duration, and current limit
- Torque boost: full range, auto
- Power loss ride-thru: 1 sec. min
- Speed search
- Auto restart
- 3 Critical frequency rejection settings
- Slip Compensation

Design Features

- 16-bit microprocessor logic
- Digital keypad operator
- Programmable form C contact for customer use: 1A at 250 VAC or 30 VDC
- 24 VDC control logic
- Carrier frequency: 2.5-10 kHz
- 8 Multi-speed settings
- Remote speed reference:
0-10 VDC (20K ohms) or
4-20 mA (250 ohms)
- Signal follower: bias and gain
- Analog monitor output:
0-10 VDC proportional to output frequency or current
- Over 70 programmable functions
- Fully EMC compliant when optional RFI filter connected
- MTBF: exceeds 28 years
- Protected chassis

Standards

- UL listed
- cUL
- IEEE STD 444 (ANSI-C343)
- IEC: 146A

Protective Features

- Current limited stall prevention during accel, decel and run
- DC bus CHARGE indicator
- Isolated operator controls
- Short circuit protection
- Ground fault protection
- UL 508C programmable electronic motor overload

Service Conditions

- Ambient service temperature: -10°C to 50°C (14° to 122°F)
- Ambient storage temperature: -20° to 60°C (-4° to 140°F)
- Humidity: to 90% non-condensing
- Altitude: to 3300 ft; higher by derating
- Service factor: 1.0
- Input voltage: single phase 115V, ±10%
- Input frequency: 50/60 Hz, ± 5%
- Phase sequence insensitive

Options

- Dynamic braking resistor (external)
- DIN Rail Kit
- Auxiliary potentiometer card
- Remote keypad
- RS232/482/485 Modbus RTU Serial Communications (Consult Factory)



VS mini Drives - 1/8-1HP, 115V, 1-phase input, protected chassis enclosure, 230V, 3-phase output.

Rated Input Voltage	Drive Model Number CIMR-XCBM	Old Model Number GPD205-	Rated Output Current (Amps)	Nominal HP ⁽¹⁾
115V, 1-Phase	AOP10	10P1	0.8	1/8
	AOP20	10P2	1.5	1/4
	AOP40	10P7	3.0	1/2 & 3/4
	AOP70	1001	5.0	1

(1) Horsepower rating is based on standard NEMA B 4-pole motor design as represented in NEC table 430.150 Full-Load Current, Three-Phase Alternating Current Motors



Dimensions and Data

Rated Input Voltage	Drive Model Number CIMR-XCBM	Rated Output Current (Amps)	Nominal HP (¹)	Physical Dimensions (in.)			Mounting Dimensions (in.)		Weight (lbs) (²)	Standard Enclosure	Heat Loss (watts)
				H	W	D	H1	W1			
115V, 1-Phase	A0P10	0.8	1/8	5.04	2.68	3.74	4.64	2.20	1.3	Protected Chassis	13
	A0P20	1.5	1/4			4.25					22
	A0P40	3.0	1/2 & 3/4		4.25	5.12	2.9	39			
	A0P70	5.0	1			6.10	3.78	3.1			61

(1) Horsepower rating is based on standard NEMA B 4-pole motor design as represented in NEC table 430.150 Full-Load Current, Three-Phase Alternating Current Motors

(2) This data represents the drive weight only, not shipping weight.



Fig. 1

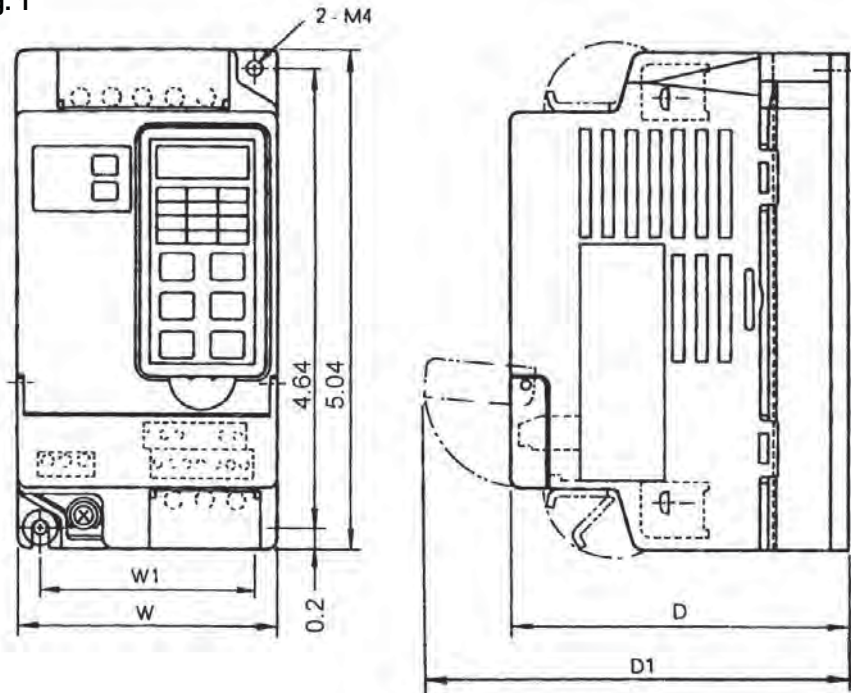
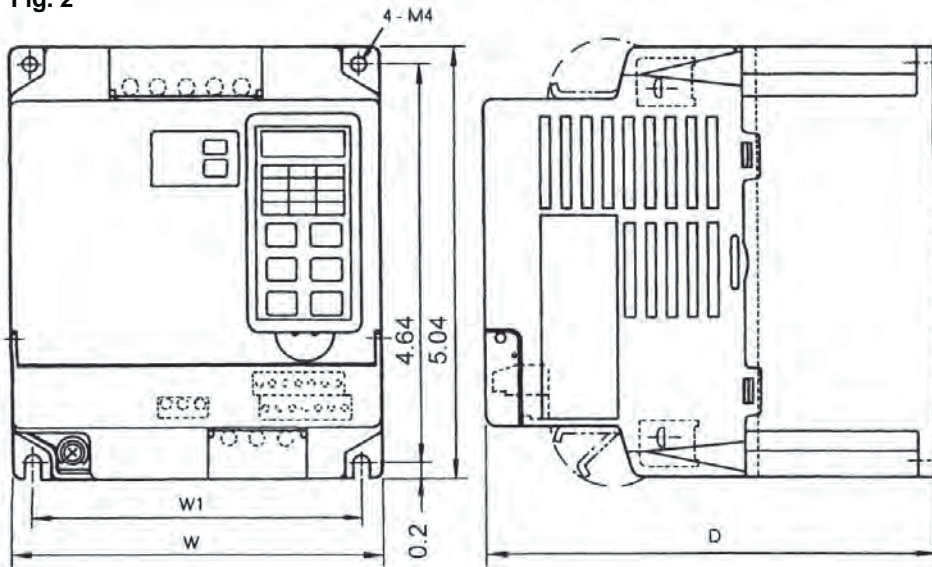

Fig. 2



Voltage	Model CIMR-XCBM	Output Current Rating (Amps)	HP	Dimensions in Inches						Figure	Approx. Weight (Lbs.)	Heat Loss (Watts)
				Mounting		H	W	D	D1			
				H1	W1							
115V, 1-Phase	A0P10	0.8	1/8	4.64	2.20	5.04	2.68	3.74	4.57	1	1.3	13
	A0P20	1.5	1/4	4.64	2.20	5.04	2.68	4.25	5.09	1	1.3	22
	A0P40	3.0	1/2 & 3/4	4.64	3.78	5.04	4.25	5.12	5.94	2	2.9	39
	A0P70	5.0	1	4.64	3.78	5.04	4.25	6.10	6.93	2	3.1	61

This page intentionally left blank



In our pursuit to create drives optimized for variable speed needs in compact applications, the J1000 is the solution. This micro-drive is simple and reliable with Yaskawa quality. Demand continues to increase for compact drives with hassle-free maintenance. Yaskawa drives have earned a reputation for high performance, high functionality, and high quality.

Great Things Come in Small Packages!

Performance Features

- Ratings:
 - 1/8 to 3 HP at 200-240 VAC 1-Ph.
 - 1/8 to 5 HP at 200-240 VAC 3-Ph.
 - 1/2 to 7.5 HP (ND) at 380-480 VAC 3-Ph.
- Overload Capacity:
 - 150% for 60 sec. (Heavy Duty)
 - 120% for 60 sec. (Normal Duty)
- Control Methods: V/f Control
- DC injection braking, ramp to stop
- Electronic reversing
- Adjustable accel/decel: 0.0 to 6000.0 seconds
- Controlled speed range: 40:1
- Speed Regulation:
 - ± 0.5 to 1% with slip compensation
- Displacement power factor: 0.98
- Output frequency: 0 to 400 Hz
- Frequency resolution:
 - 0.01 Hz with digital reference
 - 0.06 / 60 Hz with analog reference
- Frequency accuracy:
 - 0.01% with digital command
 - 0.5% with analog command
- Volts / hertz ratio: infinitely adjustable pattern
- DC Injection braking: adjustable amplitude, duration, current limited
- Torque boost: full range, auto
- Power loss ride-thru: 0.5 sec.
- Speed search
- Auto restart
- 2 Critical frequency rejection settings
- Slip Compensation

Design Features

- 16-bit microprocessor logic
- Digital keypad operator, 5 digits
- LED status display
- Remote Mount Keypad Capability
- 5 multifunction digital inputs
- 1 multifunction digital output
- Programmable form C output contact for customer use: 1A at 250 VAC or 30 VDC
- 24 VDC control logic compatible with sourcing or sinking outputs (PNP or NPN)
- Carrier frequency: 15 kHz max; swing PWM
- 8 multi-speed settings plus jog speed
- 1 Remote speed reference:
 - 0-10 VDC (20 kohms) or isolated 4-20 mA (250 ohms)
- Signal follower: bias and gain
- Analog monitor output:
 - 0-10 VDC proportional to output frequency or output current
- Approximately 140 parameters and monitors
- Cooling fan controlled by drive run/stop
- UL recognized electronic overload
- MTBF: 28 years
- Built-in Dynamic Braking Transistor
- Protected Chassis
- Side-by-Side mounting
- Maintenance monitors

Protective Features

- Current limit, stall prevention during accel, decel, and run
- Motor and drive overload
- Over voltage prevention function
- Instantaneous over current
- Short circuit
- Under voltage
- Heatsink overheat
- Ground fault protection
- Over/under torque
- Short circuit current rating: 30kA rms sym.

Service Conditions

- Ambient service temperature:
 - 10° to 50°C (+14° to 122°F)
- Ambient storage temperature:
 - 20° to 60°C (-4° to 140°F)
- Humidity: to 95% non-condensing
- Altitude: to 3300 ft; higher by derating
- Service factor: 1.0
- Input voltage: -15% to +10%
 - 200 to 240 VAC, 380 to 480 VAC
- Input frequency: +/-5%; 50/60 Hz
- Input phase sequence insensitive

Options

- Dynamic Braking resistor (external)
- Remote LED Operator w/ copy function
- Modbus 232/422/485 Communications
- Analog Potentiometer Card
- DriveWizard Plus
- DIN rail mounting kit
- USB Copy Unit (Y-Stick)
- Reactors, 3% and 5%
- EMC filters, C1 and C3

Standards

- UL 508C (Power Conversion)
- CSA 22.2 No. 14-95 (Industrial Control Equipment)
- UL, cUL listed; CE marked
- RoHS compliant
- EN 50178 (LVD)
- EN 50081-2, EN 50082-2 (EMC)
- EN 61800-3
- IEC 529, 146
- FCC CFR 47 Part 15 Subpart B (w/ External Filter)

This page intentionally left blank

Rated Input Voltage	Drive Model Number CIMR-JU	Normal Duty ⁽¹⁾		Heavy Duty ⁽¹⁾	
		Rated Output Current (Amps)	Nominal HP ⁽²⁾	Rated Output Current (Amps)	Nominal HP ⁽²⁾
200-240V 1-Phase	BA0001BAA	1.2	1/8 & 1/4	0.8	1/8
	BA0002BAA	1.9	1/4	1.6	1/4
	BA0003BAA	3.3	1/2 & 3/4	3.0	1/2
	BA0006BAA	6.0	1	5.0	3/4 & 1
	BA0010BAA	9.6	2 & 3	8.0	2
200-240V 3-Phase	2A0001BAA	1.2	1/8 & 1/4	0.8	1/8
	2A0002BAA	1.9	1/4	1.6	1/4
	2A0004BAA	3.3	1/2 & 3/4	3.0	1/2
	2A0006BAA	6.0	1	5.0	3/4 & 1
	2A0010BAA	9.6	2 & 3	8.0	2
	2A0012BAA	12.0	3	11.0	3
	2A0020BAA	19.6	5	17.5	5
380-480V 3-Phase	4A0001BAA	1.2	1/2	1.2	1/2
	4A0002BAA	2.1	3/4 & 1	1.8	3/4
	4A0004BAA	4.1	2	3.4	1 & 2
	4A0005BAA	5.4	3	4.8	3
	4A0007BAA	6.9	4	5.5	3
	4A0009BAA	8.8	5	7.2	4
	4A0011BAA	11.1	7.5	9.2	5

- (1) Normal Duty overload current rating is 120% of rated output current for 60 seconds; Heavy Duty overload current rating is 150% of rated output current for 60 seconds
- (2) Horsepower rating is based on 230-volt and 460-volt induction-type squirrel-cage NEMA B 4-pole motors as represented in NEC table 430.250 Full-Load Current, Three-Phase Alternating Current Motors

Dimensions and Data

Rated Input Voltage	Drive Model Number CIMR-JU	Normal Duty		Heavy Duty		Physical Dimensions (in.)			Mounting Dimensions (in.)		Weight (lbs.) ⁽¹⁾
		Rated Output Current (Amps)	Nominal HP	Rated Output Current (Amps)	Nominal HP	H	W	D	H1	W1	
200-240V 1-Phase	BA0001BAA	1.2	1/8 & 1/4	0.8	1/8	5.00	2.68	2.99	4.60	2.20	1.3
	BA0002BAA	1.9	1/4	1.6	1/4	5.00	2.68	2.99	4.60	2.20	1.3
	BA0003BAA	3.3	1/2 & 3/4	3.0	1/2	5.00	2.68	4.65	4.60	2.20	2.2
	BA0006BAA	6.0	1 & 1.5	5.0	3/4 & 1	5.00	4.25	5.41	4.60	3.78	3.5
	BA0010BAA	9.6	2 & 3	8.0	2	5.00	4.25	6.06	4.60	3.78	4.0
200-240V 3-Phase	2A0001BAA	1.2	1/8 & 1/4	0.8	1/8	5.00	2.68	2.99	4.60	2.20	1.3
	2A0002BAA	1.9	1/4	1.6	1/4	5.00	2.68	2.99	4.60	2.20	1.3
	2A0004BAA	3.5	1/2 & 3/4	3.0	1/2	5.00	2.68	4.25	4.60	2.20	2.0
	2A0006BAA	6.0	1 & 1.5	5.0	3/4 & 1	5.00	2.68	5.04	4.60	2.20	2.4
	2A0010BAA	9.6	2 & 3	8.0	2	5.00	4.25	5.08	4.60	3.78	3.8
	2A0012BAA	12.0	3	11.0	3	5.00	4.25	5.41	4.60	3.78	3.8
	2A0020BAA	19.6	5	17.5	5	5.00	5.51	5.63	4.60	5.04	5.3
380-480V 3-Phase	4A0001BAA	1.2	1/2	1.2	1/2	5.00	4.25	3.19	4.60	3.78	2.2
	4A0002BAA	2.1	3/4 & 1	1.8	3/4	5.00	4.25	3.90	4.60	3.78	2.7
	4A0004BAA	4.1	2	3.4	1 & 2	5.00	4.25	5.41	4.60	3.78	3.8
	4A0005BAA	5.4	3	4.8	3	5.00	4.25	6.06	4.60	3.78	3.8
	4A0007BAA	6.9	4	5.5	3	5.00	4.25	6.06	4.60	3.78	3.8
	4A0009BAA	8.8	5	7.2	4	5.00	4.25	6.06	4.60	3.78	3.8
	4A0011BAA	11.1	7.5	9.2	5	5.00	5.51	5.63	4.60	5.04	5.3

(1) This data represents the drive weight only, not shipping weight.

Dimension Drawing

DD.J1000.01

Protected Chassis

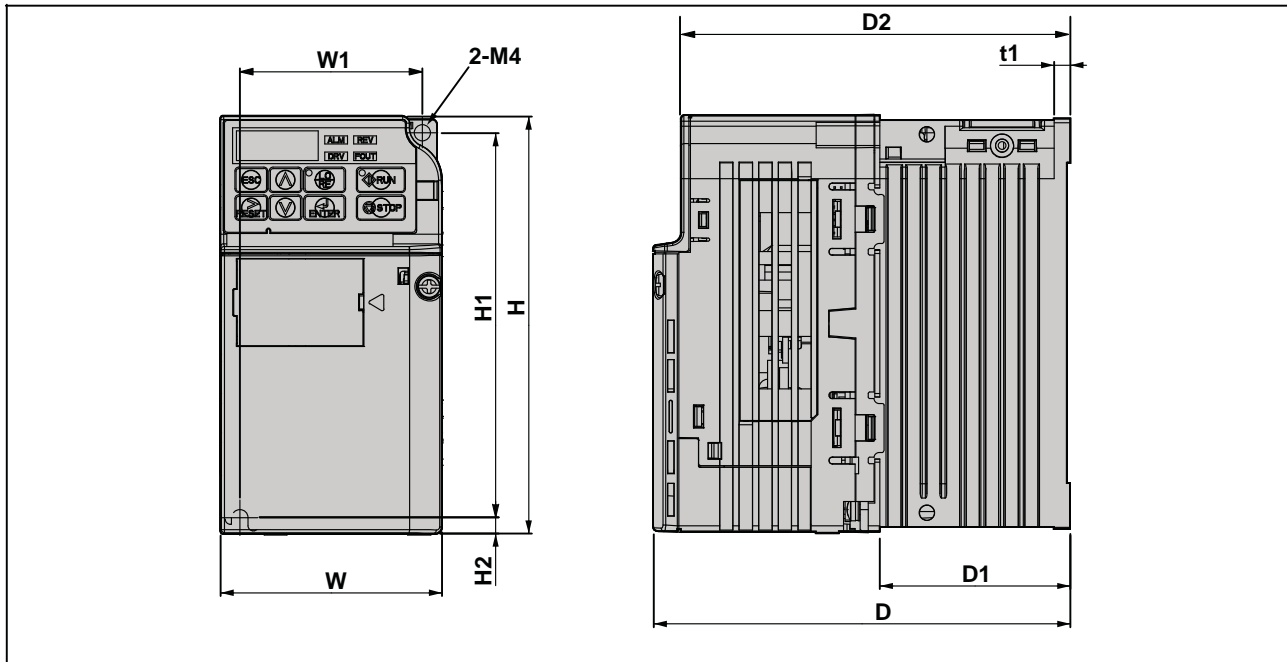
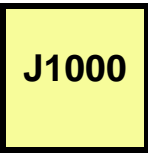

Voltage Class	Drive Model CIMR-J□	Dimensions (in)									Weight (lb.)
		W	H	D	W1	H1	H2	D1	D2	t1	
Single-Phase 200 V Class	BA0001B	2.7	5.0	3.0	2.2	4.6	0.2	0.3	2.7	0.1	1.3
	BA0002B	2.7	5.0	3.0	2.2	4.6	0.2	0.3	2.7	0.1	1.3
	BA0003B	2.7	5.0	4.6	2.2	4.6	0.2	1.5	4.3	0.2	2.2
Three-Phase 200 V Class	2A0001B	2.7	5.0	3.0	2.2	4.6	0.2	0.3	2.7	0.1	1.3
	2A0002B	2.7	5.0	3.0	2.2	4.6	0.2	0.3	2.7	0.1	1.3
	2A0004B	2.7	5.0	4.3	2.2	4.6	0.2	1.5	3.9	0.2	2.0
	2A0006B	2.7	5.0	5.0	2.2	4.6	0.2	2.3	4.7	0.2	2.4

J1000

Dimension Drawing

DD.J1000.02
Protected Chassis

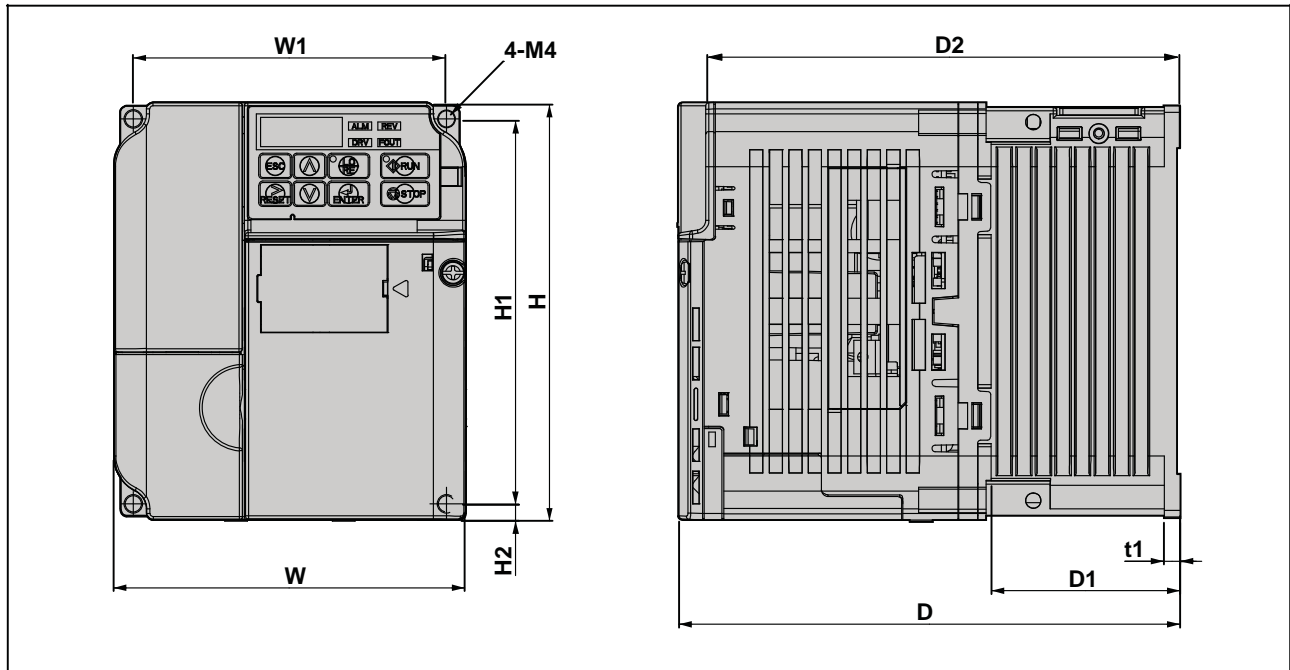

Voltage Class	Drive Model CIMR-J□	Dimensions (in)									Weight (lb.)
		W	H	D	W1	H1	H2	D1	D2	t1	
Single-Phase 200 V Class	BA0006B	4.3	5.0	5.4	3.8	4.6	0.2	2.3	5.1	0.2	3.8
	BA0010B	4.3	5.0	6.1	3.8	4.6	0.2	2.3	5.7	0.2	4.0
Three-Phase 200 V Class	2A0010B	4.3	5.0	5.1	3.8	4.6	0.2	2.3	4.7	0.2	3.8
	2A0012B	4.3	5.0	5.4	3.8	4.6	0.2	2.3	5.1	0.2	3.8
	2A0020B	5.5	5.0	5.6	5.0	4.6	0.2	2.6	5.3	0.2	5.3
Three-Phase 400 V Class	4A0001B	4.3	5.0	3.2	3.8	4.6	0.2	0.4	2.9	0.2	2.2
	4A0002B	4.3	5.0	3.9	3.8	4.6	0.2	1.1	3.6	0.2	2.7
	4A0004B	4.3	5.0	5.4	3.8	4.6	0.2	2.3	5.1	0.2	3.8
	4A0005B	4.3	5.0	6.1	3.8	4.6	0.2	2.3	5.7	0.2	3.8
	4A0007B	4.3	5.0	6.1	3.8	4.6	0.2	2.3	5.7	0.2	3.8
	4A0009B	4.3	5.0	6.1	3.8	4.6	0.2	2.3	5.7	0.2	3.8
	4A0011B	5.5	5.0	5.6	5.0	4.6	0.2	2.6	5.3	0.2	5.3



Reactor, 3% and 5% Impedance - may be used on either the input or output of a drive to reduce the effect of load or line side transients on the drive. The three-phase reactors are available loose in a separate NEMA 1 enclosure.

Rated Input Voltage	Drive Model Number CIMR-JU	Rated Output Current (Amps)	Nominal HP	3% Enclosed Reactor			5% Enclosed Reactor				
				Part Number 05P00620-	Dimensions (in.)			Part Number 05P00620-	Dimensions (in.)		
					H	L	W		H	L	W
200-240V 1-Phase	BA0001BAA	1.2	1/8 & 1/4	0020	8.0	8.0	6.0	0015	8.0	8.0	6.0
	BA0002BAA	1.9	1/4					0021			
	BA0003BAA	3.3	1/2 & 3/4					0021			
	BA0006BAA	6.0	1					0028			
200-240V 3-Phase	BA0010BAA	9.6	2 & 3	0027	8.0	8.0	6.0	0028	8.0	8.0	6.0
	2A0001BAA	1.2	1/8 & 1/4	0020	8.0	8.0	6.0	0015	8.0	8.0	6.0
	2A0002BAA	1.9	1/4					0021			
	2A0004BAA	3.5	1/2 & 3/4	0020	8.0	8.0	6.0	0021	8.0	8.0	6.0
	2A0006BAA	6.0	1	0027	8.0	8.0	6.0	0028	8.0	8.0	6.0
	2A0010BAA	9.6	2 & 3	0027	8.0	8.0	6.0	0028	8.0	8.0	6.0
	2A0012BAA	12.0	3	0032	8.0	8.0	6.0	0033	8.0	8.0	6.0
	2A0020BAA	19.6	5	0036	8.0	8.0	6.0	0037	8.0	8.0	6.0
380-480V 3-Phase	4A0001BAA	1.2	1/2	0015	8.0	8.0	6.0	0016	8.0	8.0	6.0
	4A0002BAA	2.1	3/4 & 1	0015	8.0	8.0	6.0	0016	8.0	8.0	6.0
	4A0004BAA	4.1	2	0021	8.0	8.0	6.0	0023	8.0	8.0	6.0
	4A0005BAA	5.4	3	0028	8.0	8.0	6.0	0029	8.0	8.0	6.0
	4A0007BAA	6.9	4	0033	8.0	8.0	6.0	0034	8.0	8.0	6.0
	4A0009BAA	8.8	5	0037	8.0	8.0	6.0	0038	13.0	13.0	13.0
4A0011BAA	11.1	7.5	0042	13.0	13.0	13.0	0043	13.0	13.0	13.0	



Options

J1000 Drive

EMC C1 Filters - may be used on the input of the drive to attenuate possible drive-generated noise. Filters should always be mounted as close to the drive as possible; these are designed such that the drive can be mounted to it, pancake-style. The drive should be installed with the EMC filters listed below in order to comply with the EN 61800-3, category C1 requirements. These C1 filters meet the requirements for CE.

Rated Input Voltage	Drive Model Number CIMR-JU	Rated Output Current (Amps)	Nominal HP	C1 Filter					
				Part Number	Rated Current (A)	Dimensions (in.)			Weight (lbs)
						H	W	D	
200-240V 1-Phase	BA0001BAA	1.2	1/8 & 1/4	FS23638-10-07	10	6.65	2.80	1.77	0.97
	BA0002BAA	1.9	1/4						
	BA0003BAA	3.3	1/2 & 3/4	FS23638-20-07	20	6.65	4.37	1.97	1.76
	BA0006BAA	6.0	1						
	BA0010BAA	9.6	2 & 3						
200-240V 3-Phase	2A0001BAA	1.2	1/8 & 1/4	FS23637-8-07	8	6.65	2.80	1.57	0.88
	2A0002BAA	1.9	1/4						
	2A0004BAA	3.5	1/2 & 3/4						
	2A0006BAA	6.0	1	FS23637-14-07	14	6.65	4.37	1.77	1.28
	2A0010BAA	9.6	2 & 3						
	2A0012BAA	12.0	3						
	2A0020BAA	19.6	5	FS23637-24-07	24	6.85	5.67	1.97	1.98
380-480V 3-Phase	4A0001BAA	1.2	1/2	FS23639-5-07	5	6.65	4.37	1.77	1.10
	4A0002BAA	2.1	3/4 & 1						
	4A0004BAA	4.1	2						
	4A0005BAA	5.4	3	FS23639-10-07	10	6.65	4.37	1.77	1.54
	4A0007BAA	6.9	4						
	4A0009BAA	8.8	5						
	4A0011BAA	11.1	7.5						
				FS23639-15-07	15	6.85	5.67	1.97	1.98



EMC C3 Filters (Conducted Interference Voltage Limits) - may be used on the input of a drive to attenuate possible drive-generated noise. An input filter with proper shielding, routing and grounding between itself and the drive is designed to reduce line-conducted noise levels within the limits of EN61800-3 Category C3, $I \leq 100A$ (second environment for industrial low-voltage supply network), when the drive's output conductors are properly routed and shielded in grounded steel conduit all the way to the motor. Filters should always be mounted as close to the drive as possible. The filters in combination with the drive meet UL and CE.

Rated Input Voltage	Drive Model Number CIMR-JU	Rated Output Current (Amps)	Nominal HP	C3 Filter Kit	
				Part Number	Rated Current (A)
200-240V 1-Phase	BA0001BAA	1.2	1/8 & 1/4	FS22800-5-A	5
	BA0002BAA	1.9	1/4		
	BA0003BAA	3.3	1/2 & 3/4		
	BA0006BAA	6.0	1		
200-240V 3-Phase	BA0010BAA	9.6	2 & 3	FS22800-16-A	16
	BA0010BAA	9.6	2 & 3	FS22800-26-A	26
	2A0001BAA	1.2	1/8 & 1/4	Consult Factory	Consult Factory
	2A0002BAA	1.9	1/4		
	2A0004BAA	3.5	1/2 & 3/4		
	2A0006BAA	6.0	1		
	2A0010BAA	9.6	2 & 3		
2A0012BAA	12.0	3			
2A0020BAA	19.6	5			
380-480V 3-Phase	4A0001BAA	1.2	1/2	FS22801-3-A	3
	4A0002BAA	2.1	3/4 & 1		
	4A0004BAA	4.1	2	FS22801-6-A	6
	4A0005BAA	5.4	3	FS22801-12-A	12
	4A0007BAA	6.9	4	FS22801-12-A	12
	4A0009BAA	8.8	5	FS22801-12-A	12
	4A0011BAA	11.1	7.5	FS22801-16-A	16

Note: Kit contains filter, cover, and mounting hardware.



Options
J1000 Drive

Dynamic Braking Resistor, 3% Duty Cycle - are rated for 3% duty cycle over a 100-second interval. Approximate braking torque for each rating is listed. These resistors are designed for separate panel mounting.

Rated Input Voltage	Drive Model Number CIMR-JU	Normal Duty		Heavy Duty		3% DB Resistor							
		Rated Output Current (Amps)	Nominal HP	Rated Output Current (Amps)	Nominal HP	Part Number	Qty Reqd	Resistance (Ohms) (Each)	Power (Watts) (Each)	Approx. Braking Torque (%)	Dimensions (in.)		
											H	W	D
200-240V 1-Phase	BA0001BAA	1.2	1/8 & 1/4	0.8	1/8	R7507	1	400	150	125	7.16	1.73	0.51
	BA0002BAA	1.9	1/4	1.6	1/4	R7507	1	400	150	125	7.16	1.73	0.51
	BA0003BAA	3.5	1/2 & 3/4	3.0	1/2	R7505	1	200	150	230	7.16	1.73	0.51
	BA0006BAA	6.0	1	5.0	3/4 & 1	R7505	1	200	150	230	7.16	1.73	0.51
200-240V 3-Phase	BA0010BAA	9.6	2 & 3	8.0	2	R7504	1	100	150	125	7.16	1.73	0.51
	2A0001BAA	1.2	1/8 & 1/4	0.8	1/8	R7507	1	400	150	125	7.16	1.73	0.51
	2A0002BAA	1.9	1/4	1.6	1/4	R7507	1	400	150	125	7.16	1.73	0.51
	2A0004BAA	3.5	1/2 & 3/4	3.0	1/2	R7505	1	200	150	230	7.16	1.73	0.51
	2A0006BAA	6.0	1	5.0	3/4 & 1	R7505	1	200	150	230	7.16	1.73	0.51
	2A0010BAA	9.6	2 & 3	8.0	2	R7504	1	100	150	125	7.16	1.73	0.51
380-480V 3-Phase	2A0012BAA	12.0	3	11.0	3	R7503	1	70	150	120	7.16	1.73	0.51
	2A0020BAA	19.6	5	17.5	5	R7510	1	62	150	100	7.16	1.73	0.51
	4A0001BAA	1.2	1/2	1.2	1/2	R7508	1	750	150	230	7.16	1.73	0.51
	4A0002BAA	2.1	3/4 & 1	1.8	3/4	R7508	1	750	150	230	7.16	1.73	0.51
	4A0004BAA	4.1	2	3.4	1 & 2	R7508	1	750	150	130	7.16	1.73	0.51
	4A0005BAA	5.4	3	4.8	3	R7507	1	400	150	125	7.16	1.73	0.51
	4A0007BAA	6.9	4	5.5	3	R7507	2	400	150	125	7.16	1.73	0.51
4A0009BAA	8.8	5	7.2	4	R7507	2	400	150	125	7.16	1.73	0.51	
4A0011BAA	11.1	7.5	9.2	5	R7507	2	400	150	120	7.16	1.73	0.51	



Dynamic Braking Resistor, 10% Duty Cycle - are rated for 10% duty cycle over a 100-second interval. Approximate braking torque for each rating is listed. These resistors are designed in vented NEMA 1 enclosures for separate panel mounting. The built-in braking module supports the 3% and 10% duty cycle resistors listed here and on the previous page.

Rated Input Voltage	Drive Model Number CIMR-JU	Normal Duty		Heavy Duty		10% DB Resistor						Dimensions (in.)		
		Rated Output Current (Amps)	Nominal HP	Rated Output Current (Amps)	Nominal HP	New Part No. USR000	Qty Reqd	Resistance (Ohms) (Each)	Power (Watts) (Each)	Approx. Braking Torque (%)				
										ND	HD	L	W	H
200-240V 1-Phase	BA0001BAA	1.2	1/8 & 1/4	0.8	1/8	032	1	750	600	120	150	12	7	5
	BA0002BAA	1.9	1/4	1.6	1/4	033	1	400	350	120	150	12	7	5
	BA0003BAA	3.5	1/2 & 3/4	3.0	1/2	022	1	200	250	120	150	12	5	5
	BA0006BAA	6.0	1	5.0	3/4 & 1	035	1	150	350	102	150	12	7	5
	BA0010BAA	9.6	2 & 3	8.0	2	024	1	70	250	107	150	12	5	5
200-240V 3-Phase	2A0001BAA	1.2	1/8 & 1/4	0.8	1/8	032	1	750	600	120	150	12	7	5
	2A0002BAA	1.9	1/4	1.6	1/4	033	1	400	350	120	150	12	7	5
	2A0004BAA	3.5	1/2 & 3/4	3.0	1/2	022	1	200	250	120	150	12	5	5
	2A0006BAA	6.0	1	5.0	3/4 & 1	035	1	150	350	102	150	12	7	5
	2A0010BAA	9.6	2 & 3	8.0	2	024	1	70	250	107	150	12	5	5
	2A0012BAA	12.0	3	11.0	3		1			107	107	12	5	5
	2A0020BAA	19.6	5	17.5	5	025	1	40	846	111	111	12	7	5
380-480V 3-Phase	4A0001BAA	1.2	1/2	1.2	1/2	032	1	750	600	120	150	12	7	5
	4A0002BAA	2.1	3/4 & 1	1.8	3/4		1			120	150	12	7	5
	4A0004BAA	4.1	2	3.4	1 & 2	032	1	750	600	61	61	12	7	5
	4A0005BAA	5.4	3	4.8	3	034	1	250	350	119	119	12	7	5
	4A0007BAA	6.9	4	5.5	3	034	1	250	350	119	119	12	7	5
	4A0009BAA	8.8	5	7.2	4	035	1	150	350	118	150	12	7	5
	4A0011BAA	11.1	7.5	9.2	5	035	1	150	350	118	150	12	7	5



Options
J1000 Drive

DIN Rail Mounting Kits - The DIN rail attachment kit allows the drive to be mounted on a 35 mm DIN rail. The DIN rail itself is not included in the kit. Option kit for customer mounting.

Rated Input Voltage	Drive Model Number CIMR-JU	Rated Output Current (Amps)	Nominal HP	DIN Rail Kit
				Part Number 72606-EZZ08122
200-240V 1-Phase	BA0001BAA	1.2	1/8 & 1/4	A
	BA0002BAA	1.9	1/4	
	BA0003BAA	3.3	1/2 & 3/4	
	BA0006BAA	6.0	1	B
	BA0010BAA	9.6	2 & 3	
200-240V 3-Phase	2A0001BAA	1.2	1/8 & 1/4	A
	2A0002BAA	1.9	1/4	
	2A0004BAA	3.5	1/2 & 3/4	
	2A0006BAA	6.0	1	
	2A0010BAA	9.6	2 & 3	B
	2A0012BAA	12.0	3	
	2A0020BAA	19.6	5	
380-480V 3-Phase	4A0001BAA	1.2	1/2	B
	4A0002BAA	2.1	3/4 & 1	
	4A0004BAA	4.1	2	
	4A0005BAA	5.4	3	
	4A0007BAA	6.9	4	
	4A0009BAA	8.8	5	
	4A0011BAA	11.1	7.5	C



NEMA 1 Enclosure Kits - These kits provide a bottom metal box to protect fingers from hazardous voltages, and a top plastic cover to protect the drive from falling debris. Option kit for customer mounting.

Rated Input Voltage	Drive Model Number CIMR-JU	Rated Output Current (Amps)	Nominal HP	NEMA 1 Enclosure Kit
				Part Number EZZ020564__
200-240V 1-Phase	BA0001FAA	1.2	1/8 & 1/4	A
	BA0002FAA	1.9	1/4	
	BA0003FAA	3.3	1/2 & 3/4	B
	BA0006FAA	6.0	1	C
	BA0010FAA	9.6	2 & 3	D
200-240V 3-Phase	2A0001FAA	1.2	1/8 & 1/4	A
	2A0002FAA	1.9	1/4	
	2A0004FAA	3.5	1/2 & 3/4	
	2A0006FAA	6.0	1	G
	2A0010FAA	9.6	2 & 3	
	2A0012FAA	12.0	3	
	2A0020FAA	19.6	5	
380-480V 3-Phase	4A0001FAA	1.2	1/2	G
	4A0002FAA	2.1	3/4 & 1	C
	4A0004FAA	4.1	2	L
	4A0005FAA	5.4	3	
	4A0007FAA	6.9	4	
	4A0009FAA	8.8	5	H
4A0011FAA	11.1	7.5		



Options J1000 Drive

Remote Interface, RS232C. This option allows for RS232 communication to a Remote LED Digital Operator (JVOP-182).
Model No. SI-232/J

Remote Interface, RS232C. This option allows for RS232 communication to PC software such as DriveWizard Plus or USB Copy Unit (Y-Stick, JVOP-181).
Model No. SI-232/JC

Remote Interface, RS485/422. This option allows the drive to realize RS485/422 network communication with Modbus protocol.
Model No. SI-485/J

Analog Potentiometer Card. This option provides an analog potentiometer for frequency control, mounted to the front of the J1000 drive.
Model No. AI-V3/J

USB Copy Unit (Y-Stick). This option allows the drive to connect to the USB port on a PC. It can read, copy and verify drive parameter settings from one drive to another like drive. The unit plugs into the RS232C Remote Interface (SI-232/JC) option, sold separately.
Model No. JVOP-181

CopyUnitManager Software for USB Copy Unit (Y-Stick). This option allows the user to transfer and save parameter files from the Copy Unit (JVOP-181), sold separately, to a PC and vice versa.
No Model No.

UL Rated Remote Operator Kits. This option is used to extend the existing Digital Operator to the wall of a separately priced, oversized UL Type 1, 3R, 4, 4X, or 12 enclosure (IPX6 environment). Price includes a faceplate bezel with digital operator brackets and membrane to cover the operator cutout in the enclosure door, a 3-foot cable, a 10-foot cable, and a 1:1 template for cutting the necessary cutouts in the enclosure. Keypad can be removed after kit installation. Designed for use with the LED Operator (JVOP-182) sold separately.
Connects to RJ45 port and mounts to enclosure wall.
Model No. UUX000526 (Blank Membrane)
Model No. UUX000527 (Yaskawa Logo Membrane)

Operator, LED Digital Remote. This option allows the drive to be operated from a remote location. It requires the RS232C Remote Interface (SI-232/J), sold separately. This option also requires Installation Set A (EZZ020642A) for panel or door mounting and Remote Operator Cable (UWR0051 or UWR0052), each sold separately.
Model No. JVOP-182

Operator Cable, Remote. These cables are used to connect the Remote LED Digital Operator (JVOP-182). They are available in one (1) or three (3) meter lengths.
Model No. UWR0051 (1 meter)
Model No. UWR0052 (3 meter)

LED Keypad Installation Set A (Remote Operator Mounting Bracket Kit). This is a bracket to which the LED Digital Remote Operator (JVOP-182) attaches, and has (4) threaded holes and screws to attach to the cover of an enclosure. The kit contains (2) screws to mount the Operator to the bracket and (4) screws to attach the bracket to the enclosure.
Model No. EZZ020642A

LED Keypad Installation Set B (Remote Operator Mounting Bracket Kit). Contains a similar bracket that the keypad attaches to and has non-threaded holes for mounting to an enclosure that has the screws attached to the enclosure already. The kit contains (2) screws to mount the keypad to the bracket and (4) nuts to attach the bracket to the customer supplied screws attached to the enclosure.
Model No. EZZ020642B

DriveWizard Plus Software. This optional software package allows upload and download of parameters via PC for data storage and for programming multiple drives. The software also includes graphing and monitoring tools. It is a Windows-based program designed to make startup, commissioning, and troubleshooting of the J1000 as simple as possible. Refer to our Yaskawa website to download the software, and for more information, including minimum system requirements and cable information to interface a PC to V1000 or J1000 drives.
No Model No.

PC Interface Cable. This 6-foot cable interconnects the drive keypad port to the 9-pin communication port on a PC. It requires the RS232C Remote Interface (SI-232/JC), sold separately. This cable is used in conjunction with DriveWizard Plus software.
Model No. UWR00468-2



The V1000 is a world-class compact current vector drive that defines a new world standard. Demands for efficient production and better maintainability are on the rise, spurred by global competition. Yaskawa drives have earned a reputation for high performance, high functionality, and high quality.

Performance Features

- Ratings:
 - 1/8 to 5 HP at 200-240 VAC 1-Ph.
 - 1/8 to 25 HP (ND) at 200-240 VAC 3-Ph.
 - 1/2 to 25 HP (ND) at 380-480 VAC 3-Ph.
- Overload Capacity:
 - 150% for 60 sec. (Heavy Duty)
 - 120% for 60 sec. (Normal Duty)
- Control Methods: V/f Control, Open Loop Current Vector Control, PM Open Loop Current Vector Control
- Simple closed loop speed control
- DC injection braking, ramp to stop
- Electronic reversing
- Adjustable accel/decel: 0.01 to 6000 seconds
- Controlled speed range:
 - 40:1⁽¹⁾ 100:1⁽²⁾
- Speed Regulation:
 - ± 0.5 to 1% with slip compensation⁽¹⁾
 - ± 0.2%⁽²⁾
- Displacement power factor: 0.98
- Output frequency: 0 to 400 Hz
- Frequency resolution:
 - 0.01 Hz with digital reference
 - 0.06 / 60 Hz with analog reference
- Frequency accuracy:
 - 0.01% with digital command
 - 0.5% with analog command
- Volts / hertz ratio: infinitely adjustable pattern
- DC Injection braking: adjustable amplitude, duration, current limited
- Torque boost: full range, auto
- Power loss ride-thru: 0.5 sec.
- Speed search
- Auto restart
- 3 Critical frequency rejection settings
- Slip Compensation
- Energy Savings Function
- Enhanced PID with loss of feedback function

(1) V/f Mode

(2) Open Loop Current Vector Mode

Design Features

- Dual microprocessor logic
- Digital keypad operator, 5 digits
- LED status display
- Remote Mount Keypad Capability
- RJ-45 Style Digital Operator Connector
- 7 multifunction digital inputs
- 3 multifunction digital outputs
- Hardwire baseblock (EN954-1 Cat. 3)
- Programmable form C output contact for customer use: 1A at 250 VAC or 30 VDC
- 24 VDC control logic compatible with sourcing or sinking outputs (PNP or NPN)
- Carrier frequency: 15 kHz max; swing PWM
- 16 multi-speed settings plus jog speed
- 2 Remote speed references:
 - 0-10 VDC (20 kohms) or isolated 4-20 mA (250 ohms)
- Signal follower: bias and gain
- 2 programmable open collector outputs
- Analog monitor output:
 - 0-10 VDC proportional to output frequency or output current
- Approx. 400 parameters and monitors
- Digital pulse train input (33 kHz max.)
- Cooling fan controlled by drive run/stop
- RS-422/485 Modbus 115 kbps
- UL recognized electronic overload
- MTBF: 28 years
- Built-in Dynamic Braking Transistor
- NEMA 1 enclosure
- Side-by-Side mounting
- Application presets
- Maintenance monitors

Protective Features

- Current limit, stall prevention during accel, decel, and run
- Motor and drive overload
- Over voltage prevention function
- Instantaneous over current
- Short circuit
- Under voltage
- Heatsink overheat
- Ground fault protection
- Over/under torque
- Short circuit current rating: 30kA rms sym.

Service Conditions

- Ambient service temperature:
 - 10° to 40°C (+14° to 104°F) NEMA 1
 - 10° to 50°C (+14° to 122°F) Open Chassis
- Ambient storage temperature:
 - 20° to 60°C (-4° to 140°F)
- Humidity: to 95% non-condensing
- Altitude: to 3300 ft; higher by derating
- Service factor: 1.0
- Input voltage: -15% to +10%
 - 200 to 240 VAC, 380 to 480 VAC
- Input frequency: +/-5%; 50/60 Hz
- Input phase sequence insensitive

Options

- Dynamic Braking resistor (external)
- Multi-lingual, full-text remote LCD w/ copy
- Profibus-DP, DeviceNet Communications
- Modbus TCP/IP, EtherNet/IP Communications
- MECHATROLINK-II communications
- DriveWizard Plus
- CASE software
- DIN rail mounting kit
- USB Copy Unit (Y-Stick)
- Reactors, 3% and 5%
- EMC filters, C1 and C3
- Adapter plates
- External heatsink kits
- 24V control power unit
- Remote LED operator
- Remote LCD operator
- 120V interface

Standards

- UL 508C (Power Conversion)
- CSA 22.2 No. 14-95 (Industrial Control Equipment)
- UL, cUL listed; CE marked
- RoHS compliant
- EN 50178 (LVD)
- EN 50081-2, EN 50082-2 (EMC)
- EN 954-1, Category 3 Safety Standard
- EN 61800-3
- IEC 529, 146
- FCC CFR 47 Part 15 Subpart B (w/ External Filter)
- TUV

This page intentionally left blank

Rated Input Voltage	Drive Model Number CIMR-VU ⁽³⁾	Normal Duty ⁽¹⁾		Heavy Duty ⁽¹⁾	
		Rated Output Current (Amps)	Nominal HP ⁽²⁾	Rated Output Current (Amps)	Nominal HP ⁽²⁾
200-240V 1-Phase	BA0001FAA	1.2	1/8 & 1/4	0.8	1/8
	BA0002FAA	1.9	1/4	1.6	1/4
	BA0003FAA	3.3	1/2 & 3/4	3.0	1/2
	BA0006FAA	6.0	1	5.0	3/4 & 1
	BA0010FAA	9.6	2 & 3	8.0	2
	BA0012FAA	12.0	3	11.0	3
200-240V 3-Phase	BA0018FAA	17.5	5	17.5	5
	2A0001FAA	1.2	1/8 & 1/4	0.8	1/8
	2A0002FAA	1.9	1/4	1.6	1/4
	2A0004FAA	3.5	1/2 & 3/4	3.0	1/2
	2A0006FAA	6.0	1	5.0	3/4 & 1
	2A0010FAA	9.6	2 & 3	8.0	2
	2A0012FAA	12.0	3	11	3
	2A0020FAA	19.6	5	17.5	5
	2A0030FAA	30.0	7.5 & 10	25.0	7.5
	2A0040FAA	40.0	10	33.0	10
380-480V 3-Phase	2A0056FAA	56.0	20	47.0	15
	2A0069FAA	69.0	25	60.0	20
	4A0001FAA	1.2	1/2	1.2	1/2
	4A0002FAA	2.1	3/4 & 1	1.8	3/4
	4A0004FAA	4.1	2	3.4	1 & 2
	4A0005FAA	5.4	3	4.8	3
	4A0007FAA	6.9	4	5.5	3
	4A0009FAA	8.8	5	7.2	4
	4A0011FAA	11.1	7.5	9.2	5
	4A0018FAA	17.5	10	14.8	7.5 & 10
4A0023FAA	23.0	15	18.0	10	
4A0031FAA	31.0	20	24.0	15	
4A0038FAA	38.0	25	31.0	20	

- (1) Normal Duty overload current rating is 120% of rated output current for 60 seconds; Heavy Duty overload current rating is 150% of rated output current for 60 seconds
- (2) Horsepower rating is based on 230-volt and 460-volt induction-type squirrel-cage NEMA B 4-pole motors as represented in NEC table 430.250 Full-Load Current, Three-Phase Alternating Current Motors
- (3) All standard V1000 ratings are typically in stock.

V1000

V1000 Drive Variants

V1000 Finless - Finless (flat heatsink) drives are intended to be installed in a customer's enclosure with an external heatsink. Replace standard "FAA" at end of drive model number with "JAA" (or "LAA").

V1000 Open Chassis - Open chassis drives are intended to be installed in a customer's enclosure and meet IP20 ("BAA") or IP00 ("AAA"). Replace standard "FAA" at end of drive model number with "BAA" (or "AAA").

V1000 w/ C3 Filter - These drives include a built-in C3 filter; see "EMC C3 Filters" on page 29. Replace standard "FAA" at end of drive model number with "EAA."

Rated Input Voltage	Normal Duty ⁽¹⁾		Heavy Duty ⁽¹⁾		Finless ^(3, 4)	Open ^(3, 4)	w/ C3 Filter ^(3, 4)
	Rated Output Current (Amps)	Nominal HP ⁽²⁾	Rated Output Current (Amps)	Nominal HP ⁽²⁾	Drive Model Number CIMR-VU	Drive Model Number CIMR-VU	Drive Model Number CIMR-VU
200V, 1-Phase	1.2	1/8 & 1/4	0.8	1/8	BA0001JAA	BA0001BAA	BA0001EAA
	1.9	1/4	1.6	1/4	BA0002JAA	BA0002BAA	BA0002EAA
	3.3	1/2 & 3/4	3.0	1/2	BA0003JAA	BA0003BAA	BA0003EAA
	6.0	1	5.0	3/4 & 1	BA0006JAA	BA0006BAA	BA0006EAA
	9.6	2 & 3	8.0	2	BA0010JAA	BA0010BAA	BA0010EAA
	12.0	3	11.0	3	BA0012JAA	BA0012BAA	BA0012EAA
17.5	5	17.5	5	Consult Factory	BA0018BAA	Consult Factory	
200V, 3-Phase	1.2	1/8 & 1/4	0.8	1/8	2A0001JAA	2A0001BAA	Consult Factory
	1.9	1/4	1.6	1/4	2A0002JAA	2A0002BAA	
	3.5	1/2 & 3/4	3.0	1/2	2A0004JAA	2A0004BAA	
	6.0	1	5.0	3/4 & 1	2A0006JAA	2A0006BAA	
	9.6	2 & 3	8.0	2	2A0010JAA	2A0010BAA	
	12.0	3	11.0	3	2A0012JAA	2A0012BAA	
	19.6	5	17.5	5	2A0020JAA	2A0020BAA	
	30.0	7.5 & 10	25.0	7.5	2A0030JAA	2A0030AAA	
	40.0	10	33.0	10	2A0040JAA	2A0040AAA	
	56.0	20	47.0	15	2A0056JAA	2A0056AAA	
69.0	25	60.0	20	2A0069LAA	2A0069AAA		
400V, 3-Phase	1.2	1/2	1.2	1/2	4A0001JAA	4A0001BAA	4A0001EAA
	2.1	3/4 & 1	1.8	3/4	4A0002JAA	4A0002BAA	4A0002EAA
	4.1	2	3.4	1 & 2	4A0004JAA	4A0004BAA	4A0004EAA
	5.4	3	4.8	3	4A0005JAA	4A0005BAA	4A0005EAA
	6.9	4	5.5	3	4A0007JAA	4A0007BAA	4A0007EAA
	8.8	5	7.2	4	4A0009JAA	4A0009BAA	4A0009EAA
	11.1	7.5	9.2	5	4A0011JAA	4A0011BAA	4A0011EAA
	18.0	10	15.0	7.5 & 10	4A0018JAA	4A0018AAA	Consult Factory
	23.0	15	18.0	10	4A0023JAA	4A0023AAA	
	31.0	20	25.8	15	4A0031JAA	4A0031AAA	
38.0	25	31.7	20	4A0038JAA	4A0038AAA		

(1) Normal Duty overload current rating is 120% of rated output current for 60 seconds; Heavy Duty overload current rating is 150% of rated output current for 60 seconds

(2) Horsepower rating is based on standard NEMA B 4-pole motor design and NEC table 430.150 Full-Load Current, Three-Phase Alternating Current Motors

(3) All variant drives have a 16-week lead time unless a forecast is provided

(4) Consult factory to ensure any desired options are compatible with variant drives



V1000 Conformal Coat - These drives include circuit boards that have been conformally coated with Humiseal™ for humidity and dust resistance. Note that this variant is only available in open chassis at this time. Replace standard “FAA” at end of drive model number with “BMA” (or “AMA”).

V1000 Shakeproof - These drives include components that have been strengthened for increased vibration resistance. Note that this variant is only available in finless version at this time. Replace standard “FAA” at end of drive model number with “JSA.”

V1000 w/ 1167 Hz Software - These drives include custom software that allows output frequencies up to 1167 Hz. Delete “CIMR-” prefix and add “-134” at end of drive model number.

Rated Input Voltage	Normal Duty ⁽¹⁾		Heavy Duty ⁽¹⁾		Conformal Coat ^(3, 4)	Shakeproof ^(3, 4)	1167 Hz ^(3, 4)
	Rated Output Current (Amps)	Nominal HP ⁽²⁾	Rated Output Current (Amps)	Nominal HP ⁽²⁾	Drive Model Number CIMR-VU	Drive Model Number CIMR-VU	Drive Model Number VU
200V, 1-Phase	1.2	1/8 & 1/4	0.8	1/8	Consult Factory	Consult Factory	BA0001FAA-134
	1.9	1/4	1.6	1/4			BA0002FAA-134
	3.3	1/2 & 3/4	3.0	1/2			BA0003FAA-134
	6.0	1	5.0	3/4 & 1		BA0006FAA-134	
	9.6	2 & 3	8.0	2		BA0010JSA	BA0010FAA-134
	12.0	3	11.0	3		Consult Factory	BA0012FAA-134
	17.5	5	17.5	5		Consult Factory	BA0018FAA-134
200V, 3-Phase	1.2	1/8 & 1/4	0.8	1/8	Consult Factory	Consult Factory	2A0001FAA-134
	1.9	1/4	1.6	1/4	2A0002BMA		2A0002FAA-134
	3.5	1/2 & 3/4	3.0	1/2	2A0004BMA		2A0004FAA-134
	6.0	1	5.0	3/4 & 1	2A0006BMA	2A0006JSA	2A0006FAA-134
	9.6	2 & 3	8.0	2	2A0010BMA	2A0010JSA	2A0010FAA-134
	12.0	3	11.0	3	2A0012BMA	2A0012JSA	2A0012FAA-134
	19.6	5	17.5	5	2A0020BMA	2A0020JSA	2A0020FAA-134
	30.0	7.5 & 10	25.0	7.5	2A0030BMA	2A0030JSA	2A0030FAA-134
	40.0	10	33.0	10	2A0040BMA	Consult Factory	2A0040FAA-134
	56.0	20	47.0	15	Consult Factory		2A0056FAA-134
69.0	25	60.0	20	Consult Factory	2A0069FAA-134		
400V, 3-Phase	1.2	1/2	1.2	1/2	Consult Factory	Consult Factory	4A0001FAA-134
	2.1	3/4 & 1	1.8	3/4	4A0002BMA		4A0002FAA-134
	4.1	2	3.4	1 & 2	4A0004BMA	4A0004JSA	4A0004FAA-134
	5.4	3	4.8	3	4A0005BMA	4A0005JSA	4A0005FAA-134
	6.9	4	5.5	3	4A0007BMA	4A0007JSA	4A0007FAA-134
	8.8	5	7.2	4	4A0009BMA	4A0009JSA	4A0009FAA-134
	11.1	7.5	9.2	5	4A0011BMA	4A0011JSA	4A0011FAA-134
	18.0	10	15.0	7.5 & 10	4A0018AMA	Consult Factory	4A0018FAA-134
	23.0	15	18.0	10	4A0023AMA		4A0023FAA-134
	31.0	20	25.8	15	Consult Factory		4A0031FAA-134
38.0	25	31.7	20	4A0038FAA-134			

- (1) Normal Duty overload current rating is 120% of rated output current for 60 seconds; Heavy Duty overload current rating is 150% of rated output current for 60 seconds
- (2) Horsepower rating is based on standard NEMA B 4-pole motor design and NEC table 430.150 Full-Load Current, Three-Phase Alternating Current Motors
- (3) All variant drives have a 16-week lead time unless a forecast is provided
- (4) Consult factory to ensure any desired options are compatible with variant drives

Dimensions and Data

Rated Input Voltage	Drive Model Number CIMR-VU	Normal Duty		Heavy Duty		Physical Dimensions (in.)			Mounting Dimensions		Weight (lbs.) ⁽¹⁾	Drawing Number DD.V1K.FR_
		Rated Output Current (Amps)	Nominal HP	Rated Output Current (Amps)	Nominal HP	H	W	D	H1	W1		
200-240V 1-Phase	BA0001_A	1.2	1/8 & 1/4	0.8	1/8	5.89	2.68	2.99	5.10	2.20	1.8	1
	BA0002_A	1.9	1/4	1.6	1/4	5.89	2.68	2.99	5.10	2.20	1.8	1
	BA0003_A	3.3	1/2 & 3/4	3.0	1/2	5.89	2.68	4.65	5.10	2.20	2.6	3
	BA0006_A	6.0	1	5.0	3/4 & 1	5.89	4.25	5.41	5.10	3.78	4.2	8
	BA0010_A	9.6	2 & 3	8.0	2	5.89	4.25	6.06	5.10	3.78	4.4	10
	BA0012_A	12.0	3	11.0	3	6.02	5.51	6.42	5.24	5.04	5.7	12
BA0018_A	17.5	5	17.5	5	6.02	6.69	7.09	5.24	6.22	6.6	13	
200-240V 3-Phase	2A0001_A	1.2	1/8 & 1/4	0.8	1/8	5.89	2.68	2.99	5.10	2.20	1.8	1
	2A0002_A	1.9	1/4	1.6	1/4	5.89	2.68	2.99	5.10	2.20	1.8	1
	2A0004_A	3.5	1/2 & 3/4	3	1/2	5.89	2.68	4.25	5.10	2.20	2.4	2
	2A0006_A	6.0	1	5	3/4 & 1	5.89	2.68	5.04	5.10	2.20	2.9	4
	2A0010_A	9.6	2 & 3	8	2	5.89	4.25	5.08	5.10	3.78	4.2	7
	2A0012_A	12.0	3	11	3	5.89	4.25	5.41	5.10	3.78	4.2	8
	2A0020_A	19.6	5	17.5	5	6.02	5.51	5.63	5.24	5.04	5.7	11
	2A0030_A	30.0	7.5 & 10	25.0	7.5	10.00	5.51	5.51	9.76	4.80	8.4	14
	2A0040_A	40.0	10	33.0	10	10.00	5.51	5.51	9.76	4.80	8.4	14
	2A0056_A	56.0	20	47.0	15	11.42	7.09	6.42	11.18	6.30	12.1	16
2A0069_A	69.0	25	57.5	20	14.09	8.66	7.36	13.23	7.56	20.2	17	
380-480V 3-Phase	4A0001_A	1.2	1/2	1.2	1/2	5.89	4.25	3.19	5.10	3.78	2.6	5
	4A0002_A	2.1	3/4 & 1	1.8	3/4	5.89	4.25	3.90	5.10	3.78	3.1	6
	4A0004_A	4.1	2	3.4	1 & 2	5.89	4.25	5.41	5.10	3.78	3.5	8
	4A0005_A	5.4	3	4.8	3	5.89	4.25	6.06	5.10	3.78	4.2	9
	4A0007_A	6.9	4	5.5	3	5.89	4.25	6.06	5.10	3.78	4.2	9
	4A0009_A	8.8	5	7.2	4	5.89	4.25	6.06	5.10	3.78	4.2	9
	4A0011_A	11.1	7.5	9.2	5	6.02	5.51	5.63	5.24	5.04	5.7	11
	4A0018_A	18.0	10	15.0	7.5 & 10	10.00	5.51	5.51	9.21	4.80	8.4	14
4A0023_A	24.0	15	19.2	10	10.00	5.51	5.51	9.21	4.80	8.4	14	
4A0031_A	31.0	20	25.8	15	11.42	7.09	5.63	10.63	6.30	11.4	15	
4A0038_A	38.0	25	31.7	20	11.42	7.09	6.42	10.63	6.30	12.1	16	

(1) This data represents the drive weight only, not shipping weight.

Dimension Drawing

DD.V1000.01
V1000 NEMA 1

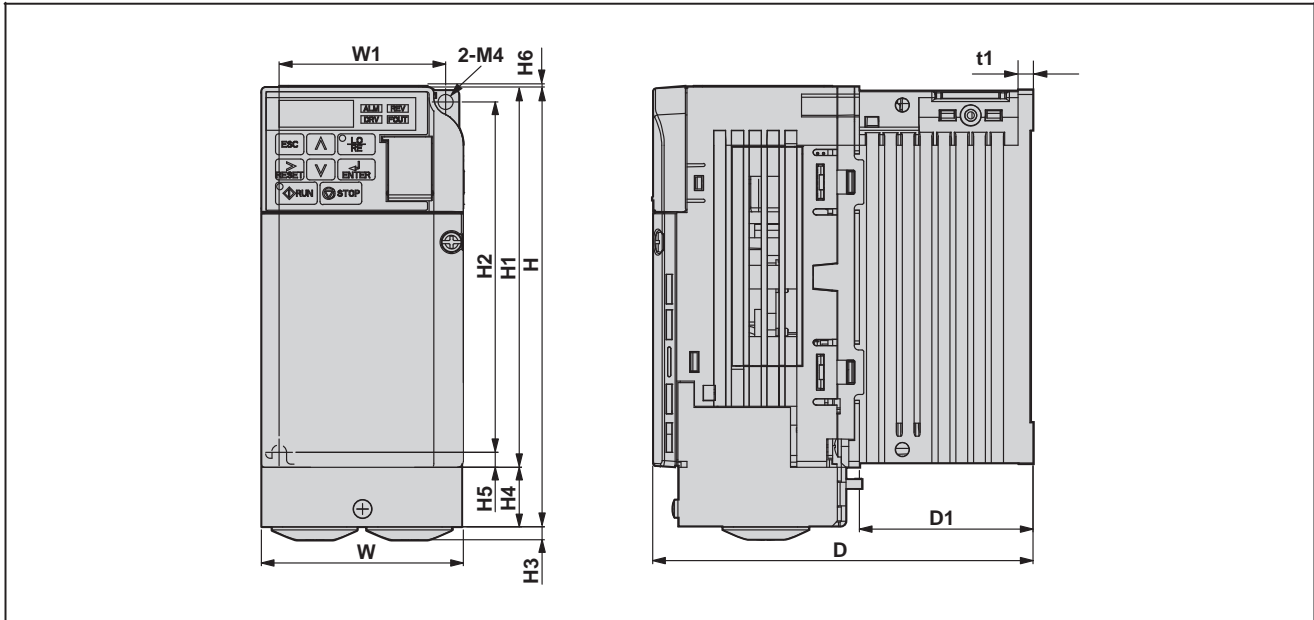

Voltage Class	Drive Model CIMR-VU	Dimensions (in)												
		W1	H2	W	H1	D	t1	H5	D1	H	H4	H3	H6	Weight (lb.)
Single-Phase 200 V Class	BA0001F	2.20	4.65	2.68	5.03	2.99	0.12	0.20	0.26	5.89	0.79	0.16	0.06	1.8
	BA0002F	2.20	4.65	2.68	5.03	2.99	0.12	0.20	0.26	5.89	0.79	0.16	0.06	1.8
	BA0003F	2.20	4.65	2.68	5.03	4.65	0.20	0.20	1.54	5.89	0.79	0.16	0.06	2.6
Three-Phase 200 V Class	2A0001F	2.20	4.65	2.68	5.03	2.99	0.12	0.20	0.26	5.89	0.79	0.16	0.06	1.8
	2A0002F	2.20	4.65	2.68	5.03	2.99	0.12	0.20	0.26	5.89	0.79	0.16	0.06	1.8
	2A0004F	2.20	4.65	2.68	5.03	4.25	0.20	0.20	1.54	5.89	0.79	0.16	0.06	2.4
	2A0006F	2.20	4.65	2.68	5.03	5.04	0.20	0.20	2.32	5.89	0.79	0.16	0.06	2.9

V1000

Dimension Drawing

DD.V1000.02

V1000 NEMA 1

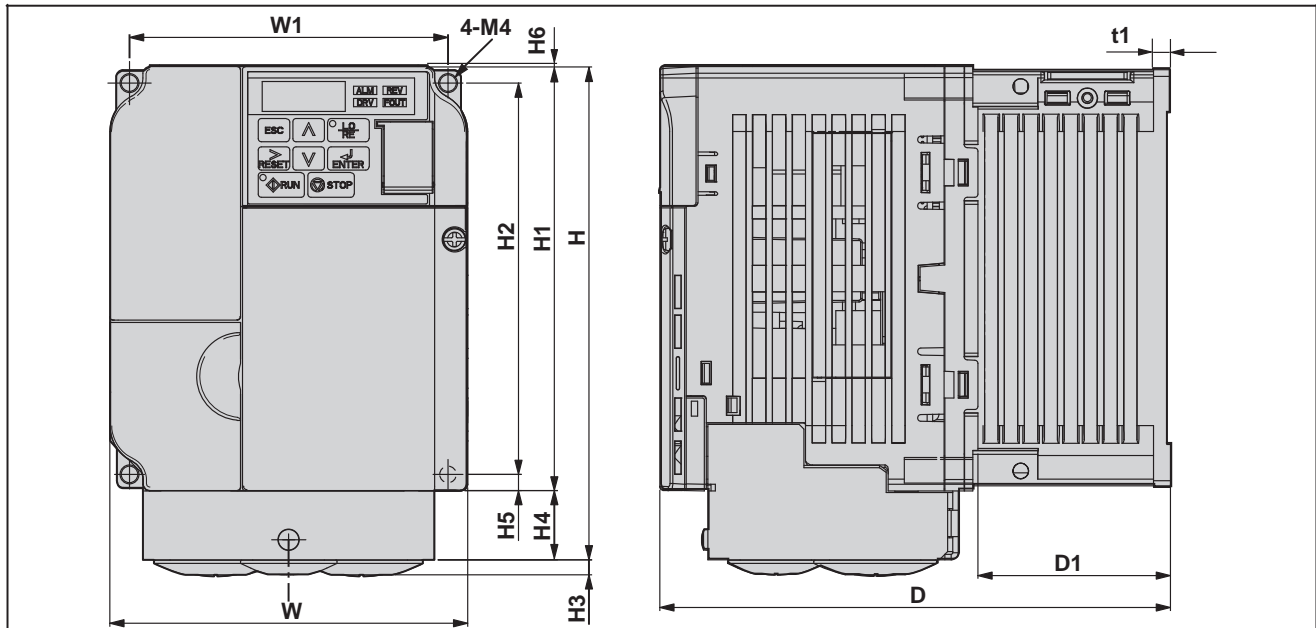

Voltage Class	Drive Model CIMR-VU	Dimensions (in)												Weight (lb.)
		W1	H2	W	H1	D	t1	H5	D1	H	H4	H3	H6	
Single-Phase 200 V Class	BA0006F	3.78	4.65	4.25	5.03	5.41	0.20	0.20	2.28	5.89	0.79	0.16	0.06	4.2
	BA0010F	3.78	4.65	4.25	5.03	6.06	0.20	0.20	2.28	5.89	0.79	0.16	0.06	4.4
	BA0012F	5.04	4.65	5.51	5.03	6.42	0.20	0.20	2.56	6.02	0.79	0.19	0.20	5.7
	BA0018F	6.22	4.64	6.69	5.23	7.08	0.20	0.20	2.56	6.73	1.50	0.19	0.20	7.3
Three-Phase 200 V Class	2A0010F	3.78	4.65	4.25	5.03	5.08	0.20	0.20	2.28	5.89	0.79	0.16	0.06	4.2
	2A0012F	3.78	4.65	4.25	5.03	5.41	0.20	0.20	2.28	5.89	0.79	0.16	0.06	4.2
	2A0020F	5.04	4.65	5.51	5.03	5.63	0.20	0.20	2.56	6.02	0.79	0.19	0.20	5.7
Three-Phase 400 V Class	4A0001F	3.78	4.65	4.25	5.03	3.19	0.20	0.20	0.39	5.89	0.79	0.16	0.06	2.6
	4A0002F	3.78	4.65	4.25	5.03	3.90	0.20	0.20	1.10	5.89	0.79	0.16	0.06	3.1
	4A0004F	3.78	4.65	4.25	5.03	5.41	0.20	0.20	2.28	5.89	0.79	0.16	0.06	4.2
	4A0005F	3.78	4.65	4.25	5.03	6.06	0.20	0.20	2.28	5.89	0.79	0.16	0.06	4.2
	4A0007F	3.78	4.65	4.25	5.03	6.06	0.20	0.20	2.28	5.89	0.79	0.16	0.06	4.2
	4A0009F	3.78	4.65	4.25	5.03	6.06	0.20	0.20	2.28	5.89	0.79	0.16	0.06	4.2
	4A0011F	5.04	4.65	5.51	5.03	5.63	0.20	0.20	2.56	6.02	0.79	0.19	0.20	5.7

Dimension Drawing

DD.V1000.03
V1000 NEMA 1

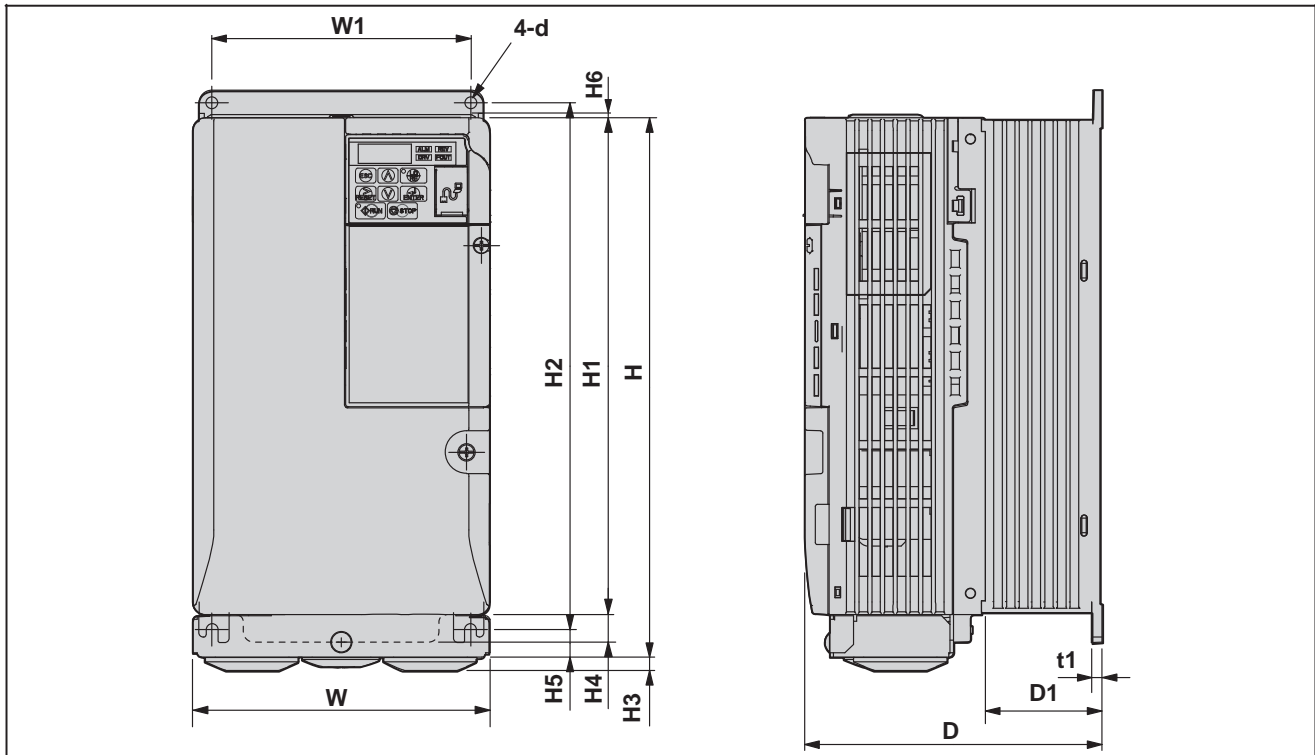

Voltage Class	Drive Model CIMR-VU	Dimensions (in)													
		W1	H2	W	H1	D	t1	H5	D1	H	H4	H3	H6	d	Weight (lb.)
Three-Phase 200 V Class	2A0030F	4.80	9.76	5.51	9.21	5.51	0.20	0.51	2.17	10.00	0.51	0.24	0.06	M5	8.4
	2A0040F	4.80	9.76	5.51	9.21	5.51	0.20	0.51	2.17	10.00	0.51	0.24	0.06	M5	8.4
	2A0056F	6.30	11.18	7.09	10.63	6.42	0.20	0.51	2.95	11.42	0.59	0.24	0.06	M5	12.1
	2A0069F	7.56	13.23	8.66	12.60	7.36	0.20	0.87	3.07	13.78	0.59	0.28	0.06	M5	20.3
Three-Phase 400 V Class	4A0018F	4.80	9.76	5.51	9.21	5.51	0.20	0.51	2.17	10.00	0.51	0.24	0.06	M5	8.4
	4A0023F	4.80	9.76	5.51	9.21	5.51	0.20	0.51	2.17	10.00	0.51	0.24	0.06	M5	8.4
	4A0031F	6.30	11.18	7.09	10.63	5.63	0.20	0.51	2.17	11.42	0.59	0.24	0.06	M5	11.5
	4A0038F	6.30	11.18	7.09	10.63	6.42	0.20	0.51	2.95	11.42	0.51	0.24	0.06	M5	12.1

This page intentionally left blank



Reactor, 3% and 5% Impedance - may be used on either the input or output of a drive to reduce the effect of load or line side transients on the drive. The three-phase reactors are available loose in a separate NEMA 1 enclosure.

Rated Input Voltage	Drive Model Number CIMR-VU	Rated Output Current (Amps)	Nominal HP	3% Enclosed Reactor			5% Enclosed Reactor				
				Part Number 05P00620-	Dimensions (in.)			Part Number 05P00620-	Dimensions (in.)		
					H	L	W		H	L	W
200-240V 1-Phase	BA0001_A	1.2	1/8 & 1/4	0020	8.0	8.0	6.0	0015	8.0	8.0	6.0
	BA0002_A	1.9	1/4								
	BA0003_A	3.3	1/2 & 3/4	0027	8.0	8.0	6.0	0021	8.0	8.0	6.0
	BA0006_A	6.0	1								
	BA0010_A	9.6	2 & 3	0032	8.0	8.0	6.0	0028	8.0	8.0	6.0
	BA0012_A	12.0	3								
BA0018_A	17.5	5	0036	8.0	8.0	6.0	0037	8.0	8.0	6.0	
200-240V 3-Phase	2A0001_A	1.2	1/8 & 1/4	0020	8.0	8.0	6.0	0015	8.0	8.0	6.0
	2A0002_A	1.9	1/4								
	2A0004_A	3.5	1/2 & 3/4	0027	8.0	8.0	6.0	0021	8.0	8.0	6.0
	2A0006_A	6.0	1								
	2A0010_A	9.6	2 & 3	0032	8.0	8.0	6.0	0028	8.0	8.0	6.0
	2A0012_A	12.0	3								
	2A0020_A	19.6	5	0036	8.0	8.0	6.0	0037	8.0	8.0	6.0
	2A0030_A	30.0	7.5 & 10	0046	13.0	13.0	13.0	0042	13.0	13.0	13.0
	2A0040_A	40.0	10								
	2A0056_A	56.0	20	0058	13.0	13.0	13.0	0055	13.0	13.0	13.0
2A0069_A	69.0	25	0059								
380-480V 3-Phase	4A0001_A	1.2	1/2	0015	8.0	8.0	6.0	0016	8.0	8.0	6.0
	4A0002_A	2.1	3/4 & 1								
	4A0004_A	4.1	2	0028	8.0	8.0	6.0	0029	8.0	8.0	6.0
	4A0005_A	5.4	3								
	4A0007_A	6.9	4	0037	8.0	8.0	6.0	0038	13.0	13.0	13.0
	4A0009_A	8.8	5								
	4A0011_A	11.1	7.5	0042	13.0	13.0	13.0	0043	13.0	13.0	13.0
	4A0018_A	17.5	10								
	4A0023_A	23.0	15	0047	13.0	13.0	13.0	0048	13.0	13.0	13.0
4A0031_A	31.0	20	0048								
4A0038_A	38.0	25	0051	13.0	13.0	13.0	0052	13.0	13.0	13.0	



Options

V1000 Drive

EMC C1 Filters - may be used on the input of the drive to attenuate possible drive-generated noise. Filters should always be mounted as close to the drive as possible; these are designed such that the drive can be mounted to it, pancake-style. The drive should be installed with the EMC filters listed below in order to comply with the EN 61800-3, category C1 requirements. These C1 filters meet the requirements for CE. Note: EMC filters for models CIMR-VU2A0030 through 0069 are in compliance with EN 61800-3, Category 2. All other models comply with Category 1.

Rated Input Voltage	Drive Model Number CIMR-VU	Rated Output Current (Amps)	Nominal HP	C1 Filter					
				Part Number	Rated Current (A)	Dimensions (in.)			Weight (lbs)
						H	W	D	
200-240V 1-Phase	BA0001__A	1.2	1/8 & 1/4	FS23638-10-07	10	6.65	2.80	1.77	0.97
	BA0002__A	1.9	1/4						
	BA0003__A	3.3	1/2 & 3/4	FS23638-20-07	20	6.65	4.37	1.97	1.76
	BA0006__A	6.0	1						
	BA0010__A	9.6	2 & 3						
	BA0012__A	12.0	3						
BA0018__A	17.5	5	FS23638-30-07	30	6.85	5.67	1.97	2.64	
200-240V 3-Phase	2A0001__A	1.2	1/8 & 1/4	FS23637-8-07	8	6.65	2.80	1.57	0.88
	2A0002__A	1.9	1/4						
	2A0004__A	3.5	1/2 & 3/4						
	2A0006__A	6.0	1	FS23637-14-07	14	6.65	4.37	1.77	1.28
	2A0010__A	9.6	2 & 3						
	2A0012__A	12.0	3						
	2A0020__A	19.6	5						
	2A0030__A	30.0	7.5 & 10	FS23637-52-07	52	11.97	5.39	2.20	4.41
	2A0040__A	40.0	10						
	2A0056__A	56.0	20	FS23637-68-07	68	13.39	6.89	2.56	5.73
2A0069__A	69.0	25	FS23637-80-07	80	15.47	8.35	2.56	6.83	
380-480V 3-Phase	4A0001__A	1.2	1/2	FS23639-5-07	5	6.65	4.37	1.77	1.10
	4A0002__A	2.1	3/4 & 1						
	4A0004__A	4.1	2						
	4A0005__A	5.4	3	FS23639-10-07	10	6.65	4.37	1.77	1.54
	4A0007__A	6.9	4						
	4A0009__A	8.8	5						
	4A0011__A	11.1	7.5						
	4A0018__A	17.5	10	FS23639-15-07	15	6.85	5.67	1.97	1.98
4A0023__A	23.0	15							
4A0031__A	31.0	20	FS23639-30-07	30	11.97	5.39	2.20	3.97	
4A0038__A	38.0	25							



EMC C3 Filters (Conducted Interference Voltage Limits) - may be used on the input of a drive to attenuate possible drive-generated noise. An input filter with proper shielding, routing and grounding between itself and the drive is designed to reduce line-conducted noise levels within the limits of EN61800-3 Category C3, $I \leq 100A$ (second environment for industrial low-voltage supply network), when the drive's output conductors are properly routed and shielded in grounded steel conduit all the way to the motor. The filters in combination with the drive meet UL and CE.

Rated Input Voltage	Drive Model Number CIMR-VU	Rated Output Current (Amps)	Nominal HP	C3 Filter Kit	
				Part Number	Rated Current (A)
200-240V 1-Phase	BA0001__A	1.2	1/8 & 1/4	FS22800-5-A	5
	BA0002__A	1.9	1/4		
	BA0003__A	3.3	1/2 & 3/4		
	BA0006__A	6.0	1		
	BA0010__A	9.6	2 & 3		
	BA0012__A	12.0	3	FS22800-33-A	33
	BA0018__A	17.5	5	Consult Factory	Consult Factory
200-240V 3-Phase	2A0001__A	1.2	1/8 & 1/4	Consult Factory	Consult Factory
	2A0002__A	1.9	1/4		
	2A0004__A	3.5	1/2 & 3/4		
	2A0006__A	6.0	1		
	2A0010__A	9.6	2 & 3		
	2A0012__A	12.0	3		
	2A0020__A	19.6	5		
	2A0030__A	30.0	7.5 & 10		
	2A0040__A	40.0	10		
	2A0056__A	56.0	20		
2A0069__A	69.0	25			
380-480V 3-Phase	4A0001__A	1.2	1/2	FS22801-3-A	3
	4A0002__A	2.1	3/4 & 1		
	4A0004__A	4.1	2	FS22801-6-A	6
	4A0005__A	5.4	3	FS22801-12-A	12
	4A0007__A	6.9	4	FS22801-12-A	12
	4A0009__A	8.8	5		
	4A0011__A	11.1	7.5	FS22801-16-A	16
	4A0018__A	17.5	10	Consult Factory	Consult Factory
4A0023__A	23.0	15			
4A0031__A	31.0	20			
4A0038__A	38.0	25			

Note: Kit contains filter, cover, and mounting hardware.



Options

V1000 Drive

Dynamic Braking Resistor, 3% Duty Cycle - are rated for 3% duty cycle over a 100-second interval. Approximate braking torque for each rating is listed. These resistors are designed for separate panel mounting.

Rated Input Voltage	Drive Model Number CIMR-VU	Normal Duty		Heavy Duty		3% DB Resistor							
		Rated Output Current (Amps)	Nominal HP	Rated Output Current (Amps)	Nominal HP	Part Number	Qty Reqd	Resistance (Ohms) (Each)	Power (Watts) (Each)	Approx. Braking Torque (%)	Dimensions (in.)		
											H	W	D
200-240V 1-Phase	BA0001__A	1.2	1/8 & 1/4	0.8	1/8	R7507	1	400	150	125	7.16	1.73	0.51
	BA0002__A	1.9	1/4	1.6	1/4	R7507	1	400	150	125	7.16	1.73	0.51
	BA0003__A	3.5	1/2 & 3/4	3.0	1/2	R7505	1	200	150	230	7.16	1.73	0.51
	BA0006__A	6.0	1	5.0	3/4 & 1	R7505	1	200	150	230	7.16	1.73	0.51
	BA0010__A	9.6	2 & 3	8.0	2	R7504	1	100	150	125	7.16	1.73	0.51
	BA0012__A	12.0	3	11.0	3	R7503	1	70	150	120	7.16	1.73	0.51
200-240V 3-Phase	2A0018__A	17.5	5	17.5	5	R7510	1	62	150	100	7.16	1.73	0.51
	2A0001__A	1.2	1/8 & 1/4	0.8	1/8	R7507	1	400	150	125	7.16	1.73	0.51
	2A0002__A	1.9	1/4	1.6	1/4	R7507	1	400	150	125	7.16	1.73	0.51
	2A0004__A	3.5	1/2 & 3/4	3.0	1/2	R7505	1	200	150	230	7.16	1.73	0.51
	2A0006__A	6.0	1	5.0	3/4 & 1	R7505	1	200	150	230	7.16	1.73	0.51
	2A0010__A	9.6	2 & 3	8.0	2	R7504	1	100	150	125	7.16	1.73	0.51
	2A0012__A	12.0	3	11.0	3	R7503	1	70	150	120	7.16	1.73	0.51
	2A0020__A	19.6	5	17.5	5	R7510	1	62	150	100	7.16	1.73	0.51
	2A0030__A	30	7.5 & 10	25.0	7.5	N/A	N/A	N/A	N/A	N/A	N/A	N/A	N/A
2A0040__A	40	10	33.0	10	N/A	N/A	N/A	N/A	N/A	N/A	N/A	N/A	
380-480V 3-Phase	4A0056__A	56	20	47.0	15	N/A	N/A	N/A	N/A	N/A	N/A	N/A	N/A
	4A0069__A	69	25	60.0	20	N/A	N/A	N/A	N/A	N/A	N/A	N/A	N/A
	4A0001__A	1.2	1/2	1.2	1/2	R7508	1	750	150	230	7.16	1.73	0.51
	4A0002__A	2.1	3/4 & 1	1.8	3/4	R7508	1	750	150	230	7.16	1.73	0.51
	4A0004__A	4.1	2	3.4	1 & 2	R7508	1	750	150	130	7.16	1.73	0.51
	4A0005__A	5.4	3	4.8	3	R7507	1	400	150	125	7.16	1.73	0.51
	4A0007__A	6.9	4	5.5	3	R7507	2	400	150	125	7.16	1.73	0.51
	4A0009__A	8.8	5	7.2	4	R7507	2	400	150	125	7.16	1.73	0.51
	4A0011__A	11.1	7.5	9.2	5	N/A	N/A	N/A	N/A	N/A	N/A	N/A	N/A
	4A0018__A	17.5	10	14.8	7.5 & 10	N/A	N/A	N/A	N/A	N/A	N/A	N/A	N/A
4A0023__A	23.0	15	18.0	10	N/A	N/A	N/A	N/A	N/A	N/A	N/A	N/A	
4A0031__A	31.0	20	24.0	15	N/A	N/A	N/A	N/A	N/A	N/A	N/A	N/A	
4A0038__A	38.0	25	31.0	20	N/A	N/A	N/A	N/A	N/A	N/A	N/A	N/A	

Dynamic Braking Resistor, 10% Duty Cycle - are rated for 10% duty cycle over a 100-second interval. Approximate braking torque for each rating is listed. These resistors are designed in vented NEMA 1 enclosures for separate panel mounting. The built-in braking module supports the 3% and 10% duty cycle resistors listed here and on the previous page. Resistors for applications requiring 50% and 100% duty cycle can be supported; please consult Yaskawa for duty cycles above 10%.

Rated Input Voltage	Drive Model Number CIMR-VU	Normal Duty		Heavy Duty		10% DB Resistor							Minimum Resistance (Ohms)		
		Rated Output Current (Amps)	Nominal HP	Rated Output Current (Amps)	Nominal HP	Part No.	Qty Reqd	Resistance (Ohms) (Each)	Power (Watts) (Each)	Approx. Braking Torque (%)		Dimensions (in.)			
										ND	HD	L		W	H
200-240V 1-Phase	BA0001_A	1.2	1/8 & 1/4	0.8	1/8	USR000032	1	750	600	120	150	12	7	5	300
	BA0002_A	1.9	1/4	1.6	1/4	USR000033	1	400	500	120	150	12	7	5	300
	BA0003_A	3.5	1/2 & 3/4	3.0	1/2	USR000022	1	200	250	120	150	12	5	5	200
	BA0006_A	6.0	1	5.0	3/4 & 1	USR000035	1	150	500	102	150	12	7	5	120
	BA0010_A	9.6	2 & 3	8.0	2	USR000024	1	70	250	107	150	12	5	5	60
	BA0012_A	12.0	3	11.0	3	USR000024	1	70	250	107	107	12	5	5	60
200-240V 3-Phase	BA0018_A	17.5	5	17.5	5	USR000025	1	40	846	111	111	12	7	5	32
	2A0001_A	1.2	1/8 & 1/4	0.8	1/8	USR000032	1	750	600	120	150	12	7	5	300
	2A0002_A	1.9	1/4	1.6	1/4	USR000033	1	400	500	120	150	12	7	5	300
	2A0004_A	3.5	1/2 & 3/4	3.0	1/2	USR000022	1	200	250	120	150	12	5	5	200
	2A0006_A	6.0	1	5.0	3/4 & 1	USR000035	1	150	500	102	150	12	7	5	120
	2A0010_A	9.6	2 & 3	8.0	2	USR000024	1	70	250	107	150	12	5	5	60
	2A0012_A	12.0	3	11.0	3	USR000024	1	70	250	107	107	12	5	5	60
	2A0020_A	19.6	5	17.5	5	USR000025	1	40	846	111	111	12	7	5	32
	2A0030_A	30	7.5 & 10	25.0	7.5	URS000148	1	18	1301	120	150	12	10	5	16
	2A0040_A	40	10	33.0	10	URS000140	1	13.6	1646	120	150	12	13	5	9.6
2A0056_A	56	20	47.0	15	URS000136	1	10.5	3402	101	135	27	10	5	9.6	
380-480V 3-Phase	2A0069_A	69	25	60.0	20	URS000136	1	10.5	3402	80	101	27	10	5	9.6
	4A0001_A	1.2	1/2	1.2	1/2	USR000032	1	750	600	120	150	12	7	5	750
	4A0002_A	2.1	3/4 & 1	1.8	3/4	USR000032	1	750	600	120	150	12	7	5	750
	4A0004_A	4.1	2	3.4	1 & 2	USR000032	1	750	600	61	61	12	7	5	510
	4A0005_A	5.4	3	4.8	3	USR000034	1	250	500	119	119	12	7	5	240
	4A0007_A	6.9	4	5.5	3	USR000034	1	250	500	119	119	12	7	5	200
	4A0009_A	8.8	5	7.2	4	USR000035	1	150	500	118	150	12	7	5	100
	4A0011_A	11.1	7.5	9.2	5	USR000036	1	100	975	117	150	12	10	5	100
	4A0018_A	17.5	10	14.8	7.5 & 10	USR000038	1	50	1600	120	150	12	13	5	32
	4A0023_A	23.0	15	18.0	10	USR000038	1	50	1600	113	150	12	13	5	32
4A0031_A	31.0	20	24.0	15	USR000039	1	40	2050	106	142	12	16	5	20	
4A0038_A	38.0	25	31.0	20	URS000154	1	27.2	2720	120	150	19	13	5	20	



Options

V1000 Drive

DIN Rail Mounting Kits - The DIN rail attachment kit allows the drive to be mounted on a 35 mm DIN rail. The DIN rail itself is not included in the kit. Option kit for customer mounting.

Rated Input Voltage	Drive Model Number CIMR-VU	Rated Output Current (Amps)	Nominal HP	DIN Rail Kit
				Part Number 72606-EZZ08122
200-240V 1-Phase	BA0001__A	1.2	1/8 & 1/4	A
	BA0002__A	1.9	1/4	
	BA0003__A	3.3	1/2 & 3/4	
	BA0006__A	6.0	1	B
	BA0010__A	9.6	2 & 3	
	BA0012__A	12.0	3	C
	BA0018__A	17.5	5	D
200-240V 3-Phase	2A0001__A	1.2	1/8 & 1/4	A
	2A0002__A	1.9	1/4	
	2A0004__A	3.5	1/2 & 3/4	
	2A0006__A	6.0	1	
	2A0010__A	9.6	2 & 3	B
	2A0012__A	12.0	3	
	2A0020__A	19.6	5	C
	2A0030__A	30.0	7.5 & 10	Not Available
	2A0040__A	40.0	10	
	2A0056__A	56.0	20	
2A0069__A	69.0	25		
380-480V 3-Phase	4A0001__A	1.2	1/2	B
	4A0002__A	2.1	3/4 & 1	
	4A0004__A	4.1	2	
	4A0005__A	5.4	3	
	4A0007__A	6.9	4	
	4A0009__A	8.8	5	
	4A0011__A	11.1	7.5	C
	4A0018__A	18.0	10	Not Available
	4A0023__A	23.0	15	
	4A0031__A	31.0	20	
4A0038__A	38.0	25		



Adapter Plate - Conversion kit used to mount a V1000 on the same footprint as a V7 drive. Not available for J1000 drives.

External Heatsink Kit - Allow for V1000 drives to be mounted with the drive's heatsink external to the enclosure. Not available for J1000 drives. Option kit for customer mounting.

Rated Input Voltage	Drive Model Number CIMR-VU	Rated Output Current (Amps)	Nominal HP	External Heatsink Kit	Adapter Kit
				Part Number EZZ020568_	Part Number EZZ020572_
230V, 1-Phase	BA0001_A	1.2	1/8 & 1/4	A	Not Required
	BA0002_A	1.9	1/4		
	BA0003_A	3.3	1/2 & 3/4	B	
	BA0006_A	6.0	1	C	
	BA0010_A	9.6	2 & 3	D	
	BA0012_A	12.0	3	E	
	BA0018_A	17.5	5	F	
230V, 3-Phase	2A0001_A	1.2	1/8 & 1/4	A	Not Required
	2A0002_A	1.9	1/4		
	2A0004_A	3.5	1/2 & 3/4	B	
	2A0006_A	6.0	1	G	
	2A0010_A	9.6	2 & 3	D	
	2A0012_A	12.0	3		
	2A0020_A	19.6	5	E	
	2A0030_A	30.0	7.5 & 10	H	B
	2A0040_A	40.0	10		
	2A0056_A	56.0	20	J	Not Required
2A0069_A	69.0	25	K		
460V	4A0001_A	1.2	1/2	L	Not Required
	4A0002_A	2.1	3/4 & 1		
	4A0004_A	4.1	2	C	
	4A0005_A	5.4	3		
	4A0007_A	6.9	4	D	
	4A0009_A	8.8	5		A
	4A0011_A	11.1	7.5	E	Not Required
	4A0018_A	18.0	10		
	4A0023_A	23.0	15	H	B
4A0031_A	31.0	20			
4A0038_A	38.0	25	J	Not Required	



Options

V1000 Drive

24VDC Control Power Unit - This option provides board-level component voltages for the V1000 drive when provided with 24VDC from an external, customer-supplied source. It is used to maintain both drive control power and network communications (when utilized). Both a Control Power Unit and a Bracket Kit are required for proper operation and certification. Option kit for customer mounting.

Rated Input Voltage	Drive Model Number CIMR-VU	Rated Output Current (Amps)	Nominal HP ⁽¹⁾	Control Power Unit	Bracket Kit
				Part Number	Part Number EZZ020639_
200-240V 1-Phase	BA0001__A	1.2	1/8 & 1/4	PS-V10S	A
	BA0002__A	1.9	1/4		
	BA0003__A	3.3	1/2 & 3/4		
	BA0006__A	6.0	1	PS-V10S	B
	BA0010__A	9.6	2 & 3		
	BA0012__A	12.0	3		
BA0018__A	17.5	5			
200-240V 3-Phase	2A0001__A	1.2	1/8 & 1/4	PS-V10S	A
	2A0002__A	1.9	1/4		
	2A0004__A	3.5	1/2 & 3/4		
	2A0006__A	6.0	1	PS-V10S	B
	2A0010__A	9.6	2 & 3		
	2A0012__A	12.0	3		
	2A0020__A	19.6	5		
	2A0030__A	30.0	7.5 & 10	PV-V10M	B
	2A0040__A	40.0	10	PS-V10M	C
2A0056__A	56.0	20			
2A0069__A	69.0	25			
380-480V 3-Phase	4A0001__A	1.2	1/2	PS-V10S	A
	4A0002__A	2.1	3/4 & 1		
	4A0004__A	4.1	2	PS-V10S	B
	4A0005__A	5.4	3		
	4A0007__A	6.9	4		
	4A0009__A	8.8	5		
	4A0011__A	11.1	7.5	PS-V10M	B
	4A0018__A	18.0	10		
	4A0023__A	23.0	15		
4A0031__A	31.0	20			
4A0038__A	38.0	25			

Operator, LCD Digital Remote, NEMA Type 1. This option allows the drive to be operated from a remote location, and provides a 16-character, 5-line alpha-numeric LCD. This option requires Installation Set A (EZZ020642A) for panel or door mounting and Remote Operator Cable (UWR0051 or UWR0052), each sold separately.

Note: This option requires the V1000 drive to contain 1012 software or later; please consult your Yaskawa representative to ensure proper operation.

Model No. JVOP-180

Operator, LED Digital Remote, NEMA Type 1. This option allows the drive to be operated from a remote location. This option requires Installation Set A (EZZ020642A) for panel or door mounting and Remote Operator Cable (UWR0051 or UWR0052), each sold separately.

Note: This option requires the V1000 drive to contain 1016 software or later; please consult your Yaskawa representative to ensure proper operation.

Model No. JVOP-182

LCD/LED Keypad Installation Set A (Remote Operator Mounting Bracket Kit). This is a bracket to which the LCD Digital Remote Operator (JVOP-180) attaches, and has (4) threaded holes and screws to attach to the cover of an enclosure. The kit contains (2) screws to mount the Operator to the bracket and (4) screws to attach the bracket to the enclosure.

Model No. EZZ020642A

LCD/LED Keypad Installation Set B (Remote Operator Mounting Bracket Kit). Contains a similar bracket that the keypad attaches to and has non-threaded holes for mounting to an enclosure that has the screws attached to the enclosure already. The kit contains (2) screws to mount the keypad to the bracket and (4) nuts to attach the bracket to the customer supplied screws attached to the enclosure.

Model No. EZZ020642B

Operator Cable, Remote. These cables are used to connect the Remote LCD Digital Operator (JVOP-180) or Remote LED Operator (JVOP-182). They are available in one (1) or three (3) meter lengths.

Model No. UWR0051 (1 meter)

Model No. UWR0052 (3 meter)

Operator Kits, NEMA Type 3R/4X. This option is used to extend an LCD or LED Digital Remote Operator to the wall of a separately priced, oversized UL Type 3R, 4, 4X, or 12 enclosure (IPX6 environment). Price includes a faceplate bezel with digital operator brackets and membrane to cover the operator cutout in the enclosure door, a 3-foot cable, a 10-foot cable, and a 1:1 template for cutting the necessary cutouts in the enclosure. Keypad can be removed after kit installation. Designed for use with the LCD Operator JVOP-180 or the LED Operator JVOP-182 sold separately. Connects to RJ45 port and mounts to enclosure wall.

Model No. UUX000526 (Blank Membrane)

Model No. UUX000527 (Yaskawa Logo Membrane)

DriveWizard Plus Software. This optional software package allows upload and download of parameters via PC for data storage and for programming multiple drives. The software also includes graphing and monitoring tools. It is a Windows-based program designed to make startup, commissioning, and troubleshooting of the J1000 as simple as possible. Refer to our Yaskawa website to download the software, and for more information, including minimum system requirements and cable information to interface a PC to V1000 or J1000 drives.

No Model No.

PC Interface Cable. This 6-foot cable interconnects the drive keypad port to the 9-pin communication port on a PC. This cable is used in conjunction with DriveWizard Plus software.

Model No. UWR00468-2

USB Copy Unit (Y-Stick). This option allows the drive to connect to the USB port on a PC. It can read, copy and verify drive parameter settings from one drive to another like drive. The unit plugs into the RJ-45 port on the front of the digital operator. Refer to our Yaskawa website to download the software.

Model No. JVOP-181

CopyUnitManager Software for USB Copy Unit (Y-Stick). This option allows the user to transfer and save parameter files from the Copy Unit (JVOP-181), sold separately, to a PC and vice versa. Refer to our Yaskawa website to download the software.

No Model No.

120 VAC Interface. This option mounts directly to the control terminal block on the drive and allows the use of 120 VAC control logic circuits to produce multi-function control input signals for the drive.

Model No. DI-100

DriveWorksEZ (DWEZ) Standard and Pro. A software system that provides the means to create custom drive functionality in the V1000 using function block programming to distribute control away from a PLC. Must attend one of the two classes below to obtain software CD.

DriveWorksEZ (DWEZ) Standard Certification. A 3-day V1000 Application Programming training class (TRM010-V1000) must be attended to become certified. Provides 20 connections and 119 basic functions.

Model No. CD.DWEZ.02

DriveWorksEZ (DWEZ) Pro Certification. A 2-day DWEZ-specific training class (TRM020-DriveWorksEZ) must be attended to become certified. This class is intended for those well-versed in V1000 programming. DWEZ Pro provides increased functionality, with 50 connections and 225 function blocks compared to the Standard version.

Model No. CD.DWEZ.03

To enroll in class, call Technical Training Services at 847-887-7228.



Options V1000 Drive

DeviceNet™ With ADR. This option complies with all pertinent aspects of the ODVA (Open DeviceNet Vendor Association) specification and AC drive profile. All parameters, diagnostics and operational commands are accessible via DeviceNet. Automatic Device Replacement (ADR) is supported in this DeviceNet option, including the functions of Auto Baud Rate sensing and Faulted Node Recovery (using Group 4 messaging). Each DeviceNet network supports up to 63 drives. Controllers are available from many PLC and/or PC suppliers. The board mounts integrally in the drive and provides a DeviceNet standard open tap connector. The option is configured using parameters within the drive, which allows for easy configuration eliminating the use of hardware switches. Status LEDs are viewable through the front cover and a monitor has been added to allow for improved diagnostics.

Note: This option requires the V1000 drive to contain 1012 software or later; please consult your Yaskawa representative to ensure proper operation.

Model No. SI-N3/V

EtherNet/IP. This option complies with the EtherNet/IP protocol specification, and allows for communication over 10/100 Mbps Ethernet networks. This option has the ability to configure the IP Address from a user specified IP address, from a DHCP host, or from a BootP host. The IP address can be set from the drive keypad or from the network. All parameters, diagnostics and operational commands are accessible via EtherNet/IP. The web interface allows management of diagnostic information through a standard web browser. The embedded web pages include the main page, drive status page, network monitor page, and documentation page.

Note: This option requires the V1000 drive to contain 1012 software or later; please consult your Yaskawa representative to ensure proper operation.

Model No. SI-EN3/V

Profibus DP. This option complies with the Profibus DP protocol specification. All parameters, diagnostics and operational commands are accessible via Profibus. The option board provides a 9-pin (F) type D-Sub connector for easily connecting to a standard Profibus style, shielded twisted-pair cable. Each Profibus network supports up to 99 drives. This option supports all of the Profibus data rates from 9.6 Kbps to 12 Mbps. Up to 32 bytes of input data and 32 bytes of output data are provided per message transaction. Sync and Freeze modes are supported for groups. Profibus DP-V1 support (cyclic and acyclic data exchange). Configurable PPO read and write parameters. The option is configured using parameters within the drive, which allows for easy configuration eliminating the use of hardware switches. Status LEDs are viewable through the front cover, and a monitor has been added to allow for improved diagnostics. Option is backwards compatible with the previous generation option cards.

Note: This option requires the V1000 drive to contain 1010 software or later; please consult your Yaskawa representative to ensure proper operation.

Model No. SI-P3/V

Modbus TCP/IP. This option complies with the Modbus TCP/IP protocol specification. This allows for Modbus communication over 10/100 Mbps Ethernet networks. This option has the ability to configure the IP Address from a user-specified IP address, from a DHCP host, or from a BootP host. All parameters, diagnostics and operational commands are accessible via Modbus TCP/IP. This option supports up to 10 simultaneous PLC/PC connections.

Note: This option requires the V1000 drive to contain 1015 software or later; please consult your Yaskawa representative to ensure proper operation.

Mounts at option connector CN5.

Model No. SI-EM3/V

MECHATROLINK-II. This option is designed for connecting a drive to a field network using the MECHATROLINK protocol. The MECHATROLINK-II option allows the user to operate the drive, monitor the status, and change parameters from a MECHATROLINK master device at a communication speed up to 10 Mbps.

Note: This option requires the V1000 drive to contain 1016 software or later; please consult your Yaskawa representative to ensure proper operation.

Model No. SI-T3/V

Description

1/8 - 25HP

V1000 NEMA 4X Drive

V1000-4X



The V1000-4X is a version of the standard V1000 in an integral enclosure that meets NEMA type 4X/12 indoor use requirements, UL type 4X/12 standards, and the IP66 rating of IEC 529. This enclosure provides the protection required in tough washdown or dust-tight environments, common in Food and Beverage Processing, Packaging, Metal Machining, Woodworking, Pumping, Refrigeration, and Printing. The enclosure is coated to protect against the harmful effects of sanitizing chemicals commonly used in food industries.

Performance Features

- Ratings:
 - 1/8 to 5 HP at 200-240 VAC 1-Phase
 - 1/8 to 25 HP (ND) at 200-240 VAC 3-Phase
 - 1/2 to 25 HP (ND) at 380-480 VAC 3-Phase
- Overload Capacity:
 - 150% for 60 sec. (Heavy Duty)
 - 120% for 60 sec. (Normal Duty)
- Control Methods: V/f Control, Open Loop Current Vector Control, PM Open Loop Current Vector Control, Simple closed loop speed control
- DC injection braking, ramp to stop
- Electronic reversing
- Adjustable accel/decel: 0.01 to 6000 seconds
- Controlled speed range:
 - 40:1⁽¹⁾ 100:1⁽²⁾
- Speed Regulation:
 - ± 0.5 to 1% with slip compensation⁽¹⁾
 - ± 0.2%⁽²⁾
- Displacement power factor: 0.98
- Output frequency: 0 to 400 Hz
- Frequency resolution:
 - 0.01 Hz with digital reference
 - 0.06 / 60 Hz with analog reference
- Frequency accuracy:
 - 0.01% with digital command
 - 0.5% with analog command
- Volts / hertz ratio: infinitely adjustable pattern
- DC Injection braking: adjustable amplitude, duration, current limited
- Torque boost: full range, auto
- Power loss ride-thru: 0.5 sec.
- Speed search
- Auto restart
- 3 Critical frequency rejection settings
- Slip Compensation
- Energy Savings Function
- Enhanced PID with loss of feedback function

Design Features

- Dual microprocessor logic
- Digital keypad operator, 5 digits
- LED status display, door-mount
- Remote Mount Keypad Capability
- RJ-45 Style Digital Operator Connector
- 7 multifunction digital inputs
- 3 multifunction digital outputs
- Hardwire baseblock (EN954-1 Cat. 3)
- Programmable form C output contact for customer use: 1A at 250 VAC or 30 VDC
- 24 VDC control logic compatible with sourcing or sinking outputs (PNP or NPN)
- Carrier frequency: 15 kHz max; swing PWM
- 16 multi-speed settings plus jog speed
- 2 Remote speed references:
 - 0-10 VDC (20 kohms) or isolated 4-20 mA (250 ohms)
- Signal follower: bias and gain
- 2 programmable open collector outputs
- Analog monitor output:
 - 0-10 VDC proportional to output frequency or output current
- Approximately 400 parameters
- Digital pulse train input (33 kHz max.)
- Cooling fan controlled by drive run/stop
- RS-422/485 Modbus 115 kbps
- UL recognized electronic overload
- MTBF: 28 years
- Built-in Dynamic Braking Transistor
- NEMA 4X/IP66 enclosure
- Application presets
- Maintenance monitors

⁽¹⁾ V/f Mode

⁽²⁾ Open Loop Current Vector Mode

Protective Features

- Current limit, stall prevention during accel, decel, and run
- Motor and drive overload
- Over voltage prevention function
- Instantaneous over current
- Short circuit
- Under voltage
- Heatsink overheat
- Ground fault protection
- Over/under torque
- Short circuit withstand rating: 30K RMS

Service Conditions

- Ambient service temperature:
 - 10° to 40°C (+14° to 104°F) NEMA 1
 - 10° to 50°C (+14° to 122°F) Open Chassis
- Ambient storage temperature:
 - 20° to 60°C (-4° to 140°F)
- Humidity: to 95% non-condensing
- Altitude: to 3300 ft; higher by derating
- Service factor: 1.0
- Input voltage: -15% to +10%
 - 200 to 240 VAC, 380 to 480 VAC
- Input frequency: +/-5%; 50/60 Hz
- Input phase sequence insensitive

Options

- 120VAC Interface
- Profibus-DP, DeviceNet Communications
- Modbus TCP/IP, EtherNet/IP Communications
- DriveWizard™ Plus
- Y-Stick Copy Unit
- Reactors, 3% and 5%
- Dynamic Braking Resistor (external)
- Multi-lingual, full text remote LCD with copy
- EMC filter Type C1

Standards

- UL 508C (Power Conversion)
- CSA 22.2 No. 14-95 (Industrial Control Equipment)
- UL, cUL listed; CE marked
- RoHS compliant
- EN 50178 (LVD)
- EN 50081-2, EN 50082-2 (EMC)
- EN 954-1, Category 3 Safety Standard
- EN 61800-3
- IEC 529, 146
- FCC CFR 47 Part 15 Subpart B (w/ External Filter)
- TUV
- NEMA type 4X/12
- IP66 rating of IEC60529

This page intentionally left blank

Rated Input Voltage	Drive Model Number CIMR-VU	Normal Duty ⁽¹⁾		Heavy Duty ⁽¹⁾	
		Rated Output Current (Amps)	Nominal HP ⁽²⁾	Rated Output Current (Amps)	Nominal HP ⁽²⁾
200-240V 1-Phase	BA0001GAA	1.2	1/8 & 1/4	0.8	1/8
	BA0002GAA	1.9	1/4	1.6	1/4
	BA0003GAA	3.3	1/2 & 3/4	3.0	1/2
	BA0006GAA	6.0	1	5.0	3/4 & 1
	BA0010GAA	9.6	2 & 3	8.0	2
	BA0012GAA	12.0	3	11.0	3
200-240V 3-Phase	2A0001GAA	1.2	1/8 & 1/4	0.8	1/8
	2A0002GAA	1.9	1/4	1.6	1/4
	2A0004GAA	3.5	1/2 & 3/4	3.0	1/2
	2A0006GAA	6.0	1	5.0	3/4 & 1
	2A0010GAA	9.6	2 & 3	8.0	2
	2A0012GAA	12.0	3	11.0	3
	2A0020GAA	19.6	5	17.5	5
	2A0030GAA	30.0	7.5 & 10	25.0	7.5
	2A0040GAA	40.0	10	33.0	10
	2A0056GAA	56.0	20	47.0	15
	2A0069GAA	69.0	25	60.0	20
380-480V 3-Phase	4A0001GAA	1.2	1/2	1.2	1/2
	4A0002GAA	2.1	3/4 & 1	1.8	3/4
	4A0004GAA	4.1	2	3.4	1 & 2
	4A0005GAA	5.4	3	4.8	3
	4A0007GAA	6.9	4	5.5	3
	4A0009GAA	8.8	5	7.2	4
	4A0011GAA	11.1	7.5	9.2	5
	4A0018GAA	17.5	10	14.8	7.5 & 10
	4A0023GAA	24.0	15	18.0	10
	4A0031GAA	31.0	20	24.0	15
	4A0038GAA	38.0	25	31.0	20

(1) Normal Duty overload current rating is 120% of rated output current for 60 seconds; Heavy Duty overload current rating is 150% of rated output current for 60 seconds

(2) Horsepower rating is based on standard NEMA B 4-pole motor design and NEC table 430.150 Full-Load Current, Three-Phase Alternating Current Motors

Dimensions and Data

Rated Input Voltage	Drive Model Number CIMR-VU	Normal Duty		Heavy Duty		Physical Dimensions (in.)			Mounting Dimensions (in.)		Weight (lbs.) ⁽¹⁾
		Rated Output Current (Amps)	Nominal HP	Rated Output Current (Amps)	Nominal HP	H	W	D	H1	W1	
200-240V 1-Phase	BA0001GAA	1.2	1/8 & 1/4	0.8	1/8	8.74	6.38	7.28	8.27	5.32	10.4
	BA0002GAA	1.9	1/4	1.6	1/4	8.74	6.38	7.28	8.27	5.32	10.4
	BA0003GAA	3.3	1/2 & 3/4	3.0	1/2	8.74	6.38	7.28	8.27	5.32	10.8
	BA0006GAA	6.0	1	5.0	3/4 & 1	10.04	7.36	9.25	9.49	6.22	17.2
	BA0010GAA	9.6	2 & 3	8.0	2	10.04	7.36	9.25	9.49	6.22	17.2
	BA0012GAA	12.0	3	11.0	3	10.04	7.36	9.25	9.49	6.22	18.1
200-240V 3-Phase	2A0001GAA	1.2	1/8 & 1/4	0.8	1/8	8.74	6.38	7.28	8.27	5.32	10.4
	2A0002GAA	1.9	1/4	1.6	1/4	8.74	6.38	7.28	8.27	5.32	10.4
	2A0004GAA	3.5	1/2 & 3/4	3.0	1/2	8.74	6.38	7.28	8.27	5.32	10.6
	2A0006GAA	6.0	1	5.0	3/4 & 1	8.74	6.38	7.28	8.27	5.32	10.6
	2A0010GAA	9.6	2 & 3	8.0	2	10.04	7.36	9.25	9.49	6.22	17.0
	2A0012GAA	12.0	3	11.0	3	10.04	7.36	9.25	9.49	6.22	17.0
	2A0020GAA	19.6	5	17.5	5	10.04	7.36	9.25	9.49	6.22	17.9
	2A0030GAA	30.0	7.5 & 10	25.0	7.5	16.54	11.42	12.01	15.75	10.43	48.1
	2A0040GAA	40.0	10	33.0	10	16.54	11.42	12.01	15.75	10.43	48.1
	2A0056GAA	56.0	20	47.0	15	16.54	11.42	12.01	15.75	10.43	51.2
2A0069GAA	69.0	25	60.0	20	18.31	11.42	12.01	17.52	10.43	61.1	
380-480V 3-Phase	4A0001GAA	1.2	1/2	1.2	1/2	8.74	6.38	7.28	8.27	5.32	11.1
	4A0002GAA	2.1	3/4 & 1	1.8	3/4	8.74	6.38	7.28	8.27	5.32	11.1
	4A0004GAA	4.1	2	3.4	1 & 2	8.74	6.38	7.28	8.27	5.32	11.3
	4A0005GAA	5.4	3	4.8	3	10.04	7.36	9.25	9.49	6.22	17.0
	4A0007GAA	6.9	4	5.5	3	10.04	7.36	9.25	9.49	6.22	17.5
	4A0009GAA	8.8	5	7.2	4	10.04	7.36	9.25	9.49	6.22	17.5
	4A0011GAA	11.1	7.5	9.2	5	10.04	7.36	9.25	9.49	6.22	17.9
	4A0018GAA	17.5	10	14.8	7.5 & 10	16.54	11.42	12.01	15.75	10.43	47.9
	4A0023GAA	24.0	15	18.0	10	16.54	11.42	12.01	15.75	10.43	48.1
	4A0031GAA	31.0	20	24.0	15	16.54	11.42	12.01	15.75	10.43	50.5
4A0038GAA	38.0	25	31.0	20	16.54	11.42	12.01	15.75	10.43	51.2	

(1) This data represents the drive weight only, not shipping weight

Dimension Drawing

DD.V1000-4X.01

NEMA 4X/IP66

V1000-4X

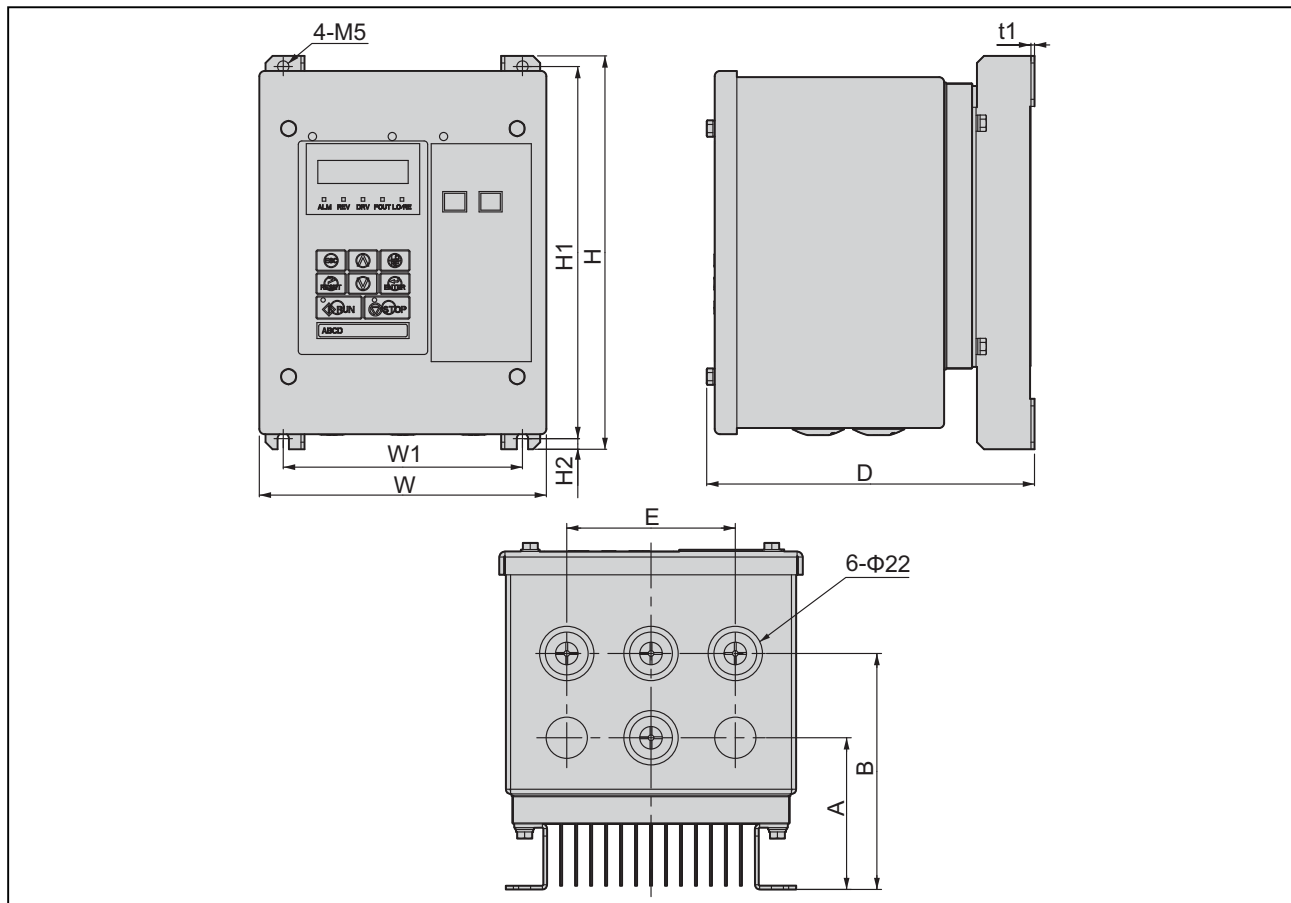

Voltage Class	Drive Model CIMR-V□	Dimensions mm (in)										Weight kg (lb.)	
		W	H	D	W1	H1	H2	t1	A	B	E		
Single-Phase 200 V Class	BA0001G												4.7 (10.36)
	BA0002G												4.7 (10.36)
	BA0003G												4.9 (10.80)
Three-Phase 200 V Class	2A0001G												4.7 (10.36)
	2A0002G	162	222	185	135	210	6	2	81	126	90		4.7 (10.36)
	2A0004G	(6.38)	(8.74)	(7.28)	(5.32)	(8.27)	(0.24)	(0.08)	(3.19)	(4.96)	(3.54)		4.8 (10.58)
	2A0006G												4.8 (10.58)
Three-Phase 400 V Class	4A0001G												5.0 (11.02)
	4A0002G												5.0 (11.02)
	4A0004G												5.1 (11.24)

**V1000-
4X**

Dimension Drawing

DD.V1000-4X.02

NEMA 4X/IP66

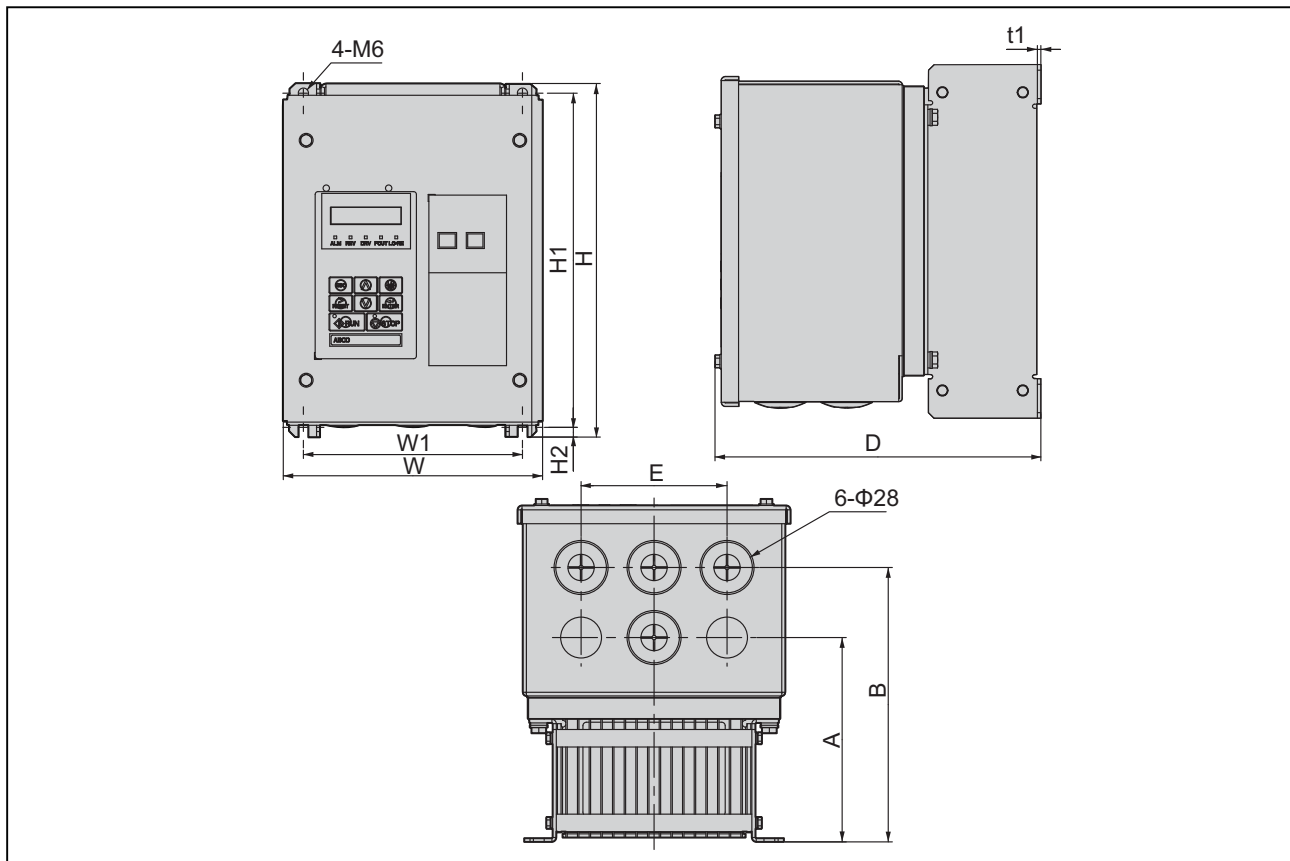

Voltage Class	Drive Model CIMR-V□	Dimensions mm (in)										
		W	H	D	W1	H1	H2	t1	A	B	E	Weight kg (lb.)
Single-Phase 200 V Class	BA0006G											7.8 (17.2)
	BA0010G											7.8 (17.2)
	BA0012G											8.2 (18.08)
Three-Phase 200 V Class	2A0010G											7.7 (16.98)
	2A0012G	187	255	235	158	241	7	2.5	140	188	100	7.7 (16.98)
	2A0020G	(7.36)	(10.04)	(9.25)	(6.22)	(9.49)	(0.28)	(0.10)	(5.51)	(7.40)	(3.94)	8.1 (17.86)
Three-Phase 400 V Class	4A0005G											7.7 (16.98)
	4A0007G											7.9 (17.42)
	4A0009G											7.9 (17.42)
	4A0011G											8.1 (17.86)

Dimension Drawing

DD.V1000-4X.03

NEMA 4X/IP66

V1000-4X

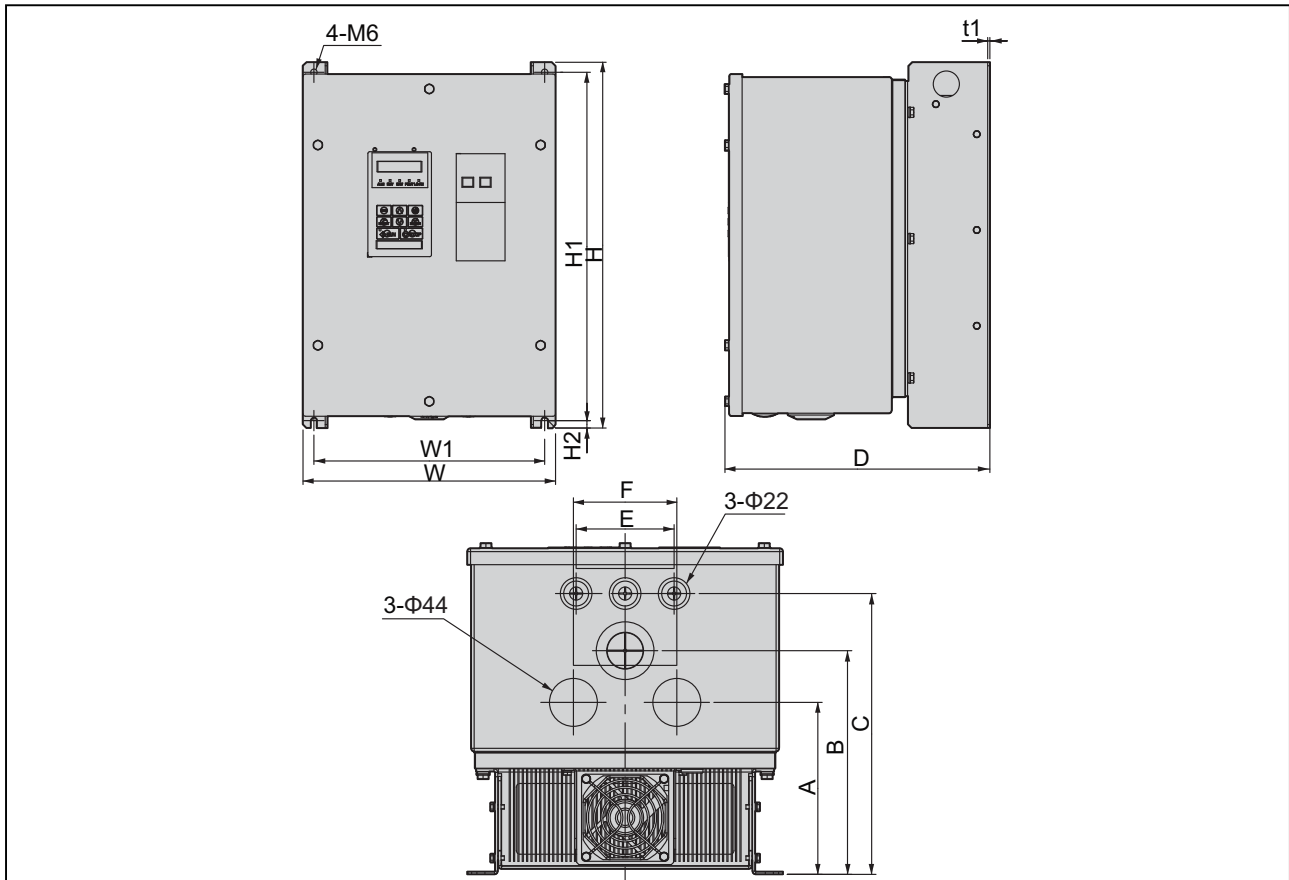

Voltage Class	Drive Model CIMR-V□	Dimensions mm (in)												Weight kg (lb.)	
		W	H	D	W1	H1	H2	t1	A	B	C	E	F		
Three-Phase 200 V Class	2A0030G														21.8 (48.06)
	2A0040G														21.8 (48.06)
	2A0056G														23.2 (51.15)
Three-Phase 400 V Class	4A0018G	290 (11.42)	420 (16.54)	305 (12.01)	265 (10.43)	400 (15.75)	8.5 (0.33)	2.5 (0.10)	158 (6.22)	205.5 (8.09)	258 (10.16)	90 (3.54)	95 (3.74)	21.7 (47.84)	
	4A0023G													21.8 (48.06)	
	4A0031G													22.9 (50.49)	
	4A0038G													23.2 (51.15)	

**V1000-
4X**

Dimension Drawing

DD.V1000-4X.04

NEMA 4X/IP66

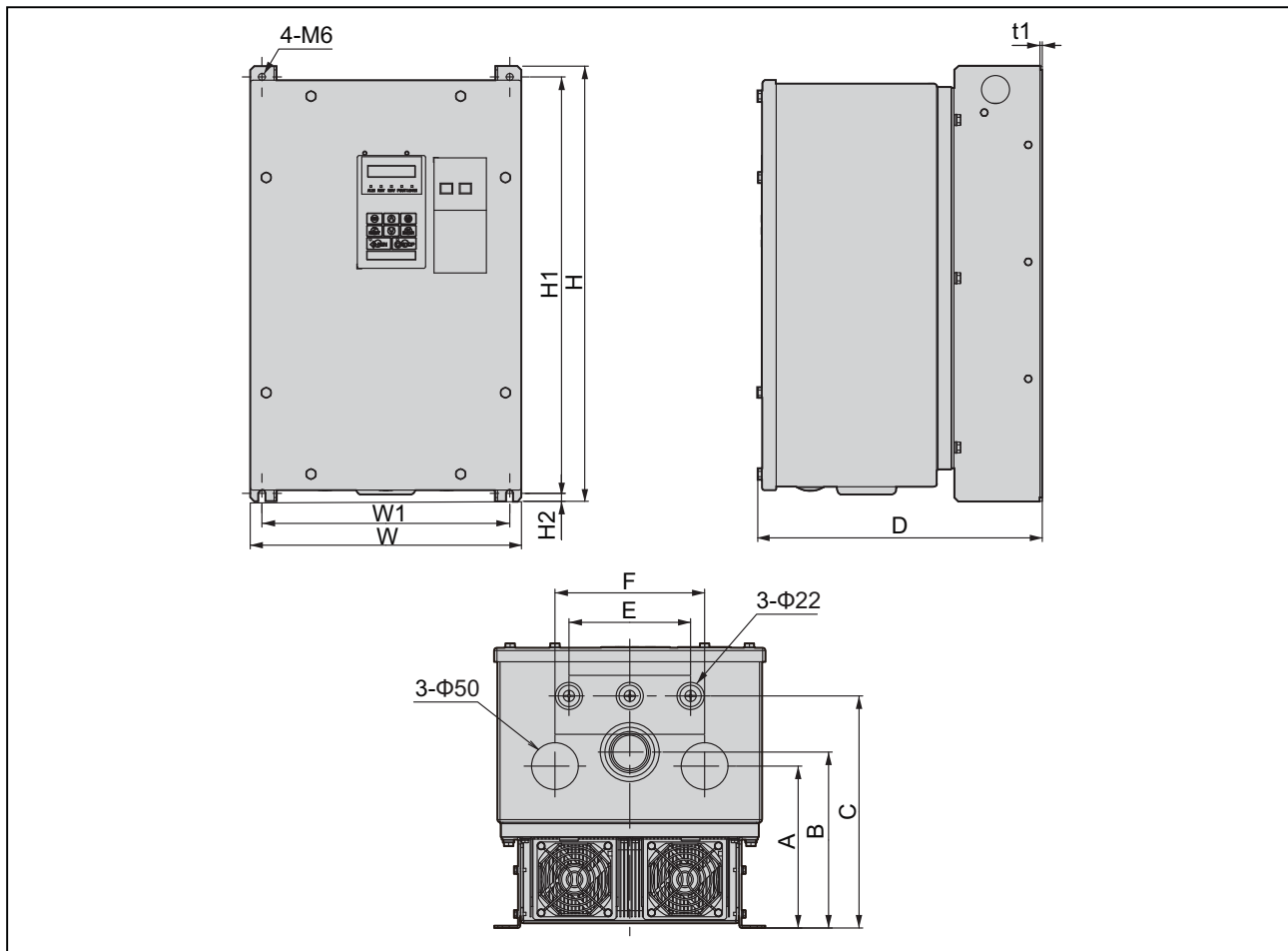

Voltage Class	Drive Model CIMR-V□	Dimensions mm (in)											Weight kg (lb.)	
		W	H	D	W1	H1	H2	t1	A	B	C	E		F
Three-Phase 200 V Class	2A0069G	290 (11.42)	465 (18.31)	305 (12.01)	265 (10.43)	445 (17.52)	8.5 (0.33)	2.5 (0.10)	173 (6.81)	188 (7.40)	248 (9.76)	130 (5.12)	160 (6.30)	27.7 (61.07)

Operator, LCD Digital Remote, NEMA Type 1. This option allows the drive to be programmed before installation from a remote location, and provides a 16-character, 5-line alpha-numeric LCD. This option requires Remote Operator Cable (UWR0051 or UWR0052), sold separately.

Note: This option requires the V1000 drive to contain 1012 software or later; please consult your Yaskawa representative to ensure proper operation.

Model No. JVOP-180

Operator Cable, Remote. These cables are used to connect the Remote LCD Digital Operator (JVOP-180). They are available in one (1) or three (3) meter lengths.

Model No. UWR0051 (1 meter)

Model No. UWR0052 (3 meter)

Operator Kits, NEMA Type 3R/4X. This option is used to extend an LCD Digital Remote Operator to the wall of a separately priced, oversized UL Type 3R, 4, 4X, or 12 enclosure (IPX6 environment). Price includes a faceplate bezel with digital operator brackets and membrane to cover the operator cutout in the enclosure door, a 3-foot cable, a 10-foot cable, and a 1:1 template for cutting the necessary cutouts in the enclosure. Keypad can be removed after kit installation. Designed for use with the LCD Operator JVOP-180 sold separately. Connects to RJ45 port and mounts to enclosure wall.

Model No. UUX000526 (Blank Membrane)

Model No. UUX000527 (Yaskawa Logo Membrane)

DriveWizard Plus Software. This optional software package allows upload and download of parameters via PC for data storage and for programming multiple drives. The software also includes graphing and monitoring tools. It is a Windows-based program designed to make startup, commissioning, and troubleshooting of the J1000 as simple as possible. Refer to our [Yaskawa website](#) to download the software, and for more information, including minimum system requirements and cable information to interface a PC to V1000 or J1000 drives.

No Model No.

PC Interface Cable. This 6-foot cable interconnects the drive keypad port to the 9-pin communication port on a PC. This cable is used in conjunction with DriveWizard Plus software.

Model No. UWR00468-2

USB Copy Unit (Y-Stick). This option allows the drive to connect to the USB port on a PC. It can read, copy and verify drive parameter settings from one drive to another like drive. The unit plugs into the RJ-45 port on the front of the digital operator. Refer to our [Yaskawa website](#) to download the software.

Model No. JVOP-181

CopyUnitManager Software for USB Copy Unit (Y-Stick). This option allows the user to transfer and save parameter files from the Copy Unit (JVOP-181), sold separately, to a PC and vice versa. Refer to our [Yaskawa website](#) to download the software.

No Model No.

120 VAC Interface. This option mounts directly to the control terminal block on the drive and allows the use of 120 VAC control logic circuits to produce multi-function control input signals for the drive.

Model No. DI-100

DriveWorksEZ (DWEZ) Standard and Pro. A software system that provides the means to create custom drive functionality in the V1000 using function block programming to distribute control away from a PLC. Must attend one of the two classes below to obtain software CD.

DriveWorksEZ (DWEZ) Standard Certification. A 3-day V1000 Application Programming training class (TRM010-V1000) must be attended to become certified. Provides 20 connections and 119 basic functions.

Model No. CD.DWEZ.02

DriveWorksEZ (DWEZ) Pro Certification. A 2-day DWEZ-specific training class (TRM020-DriveWorksEZ) must be attended to become certified. This class is intended for those well-versed in V1000 programming. DWEZ Pro provides increased functionality, with 50 connections and 225 function blocks compared to the Standard version.

Model No. CD.DWEZ.03

To enroll in class, call Technical Training Services at 847-887-7228.



Options V1000-4X Drive

DeviceNet™ With ADR. This option complies with all pertinent aspects of the ODVA (Open DeviceNet Vendor Association) specification and AC drive profile. All parameters, diagnostics and operational commands are accessible via DeviceNet. Automatic Device Replacement (ADR) is supported in this DeviceNet option, including the functions of Auto Baud Rate sensing and Faulted Node Recovery (using Group 4 messaging). Each DeviceNet network supports up to 63 drives. Controllers are available from many PLC and/or PC suppliers. The board mounts integrally in the drive and provides a DeviceNet standard open tap connector. The option is configured using parameters within the drive, which allows for easy configuration eliminating the use of hardware switches. Status LEDs are viewable through the front cover and a monitor has been added to allow for improved diagnostics.

Note: This option requires the V1000 drive to contain 1012 software or later; please consult your Yaskawa representative to ensure proper operation.

Model No. SI-N3/V

EtherNet/IP. This option complies with the EtherNet/IP protocol specification, and allows for communication over 10/100 Mbps Ethernet networks. This option has the ability to configure the IP Address from a user specified IP address, from a DHCP host, or from a BootP host. The IP address can be set from the drive keypad or from the network. All parameters, diagnostics and operational commands are accessible via EtherNet/IP. The web interface allows management of diagnostic information through a standard web browser. The embedded web pages include the main page, drive status page, network monitor page, and documentation page.

Note: This option requires the V1000 drive to contain 1012 software or later; please consult your Yaskawa representative to ensure proper operation.

Model No. SI-EN3/V

Profibus DP. This option complies with the Profibus DP protocol specification. All parameters, diagnostics and operational commands are accessible via Profibus. The option board provides a 9-pin (F) type D-Sub connector for easily connecting to a standard Profibus style, shielded twisted-pair cable. Each Profibus network supports up to 99 drives. This option supports all of the Profibus data rates from 9.6 Kbps to 12 Mbps. Up to 32 bytes of input data and 32 bytes of output data are provided per message transaction. Sync and Freeze modes are supported for groups. Profibus DP-V1 support (cyclic and acyclic data exchange). Configurable PPO read and write parameters. The option is configured using parameters within the drive, which allows for easy configuration eliminating the use of hardware switches. Status LEDs are viewable through the front cover, and a monitor has been added to allow for improved diagnostics. Option is backwards compatible with the previous generation option cards.

Note: This option requires the V1000 drive to contain 1010 software or later; please consult your Yaskawa representative to ensure proper operation.

Model No. SI-P3/V

Modbus TCP/IP. This option complies with the Modbus TCP/IP protocol specification. This allows for Modbus communication over 10/100 Mbps Ethernet networks. This option has the ability to configure the IP Address from a user-specified IP address, from a DHCP host, or from a BootP host. All parameters, diagnostics and operational commands are accessible via Modbus TCP/IP. This option supports up to 10 simultaneous PLC/PC connections.

Note: This option requires the V1000 drive to contain 1015 software or later; please consult your Yaskawa representative to ensure proper operation.

Mounts at option connector CN5.

Model No. SI-EM3/V

Technical Training

In today's world of global competition, it is impossible for a company to survive without "state-of-the-art" technically trained associates and customers. Yaskawa Electric America Technical Training Service's mission is to provide inverter drives training classes to our customers that are "right on target" with knowledge they need to perform their jobs.

Yaskawa Electric America has three training facilities in the United States. The primary training facility is in Yaskawa Electric America's North American Headquarters in Waukegan, Illinois (45 miles north of Chicago, 50 miles south of Milwaukee). This facility has four training rooms: two lecture halls and two training labs. Two additional facilities are located in Cypress, California, and Plain City, Ohio.

Besides the possibility of attending training classes in Waukegan, Yaskawa Electric America can also bring training to the customer. On-site classes are available in two varieties. The first is to duplicate the official training classes at the customer's location. Full functioning demo units, data projector, computer and documentation can be shipped to recreate the official class on-site. The second variety is road show training. Road show training is a one-day training class that is specifically tailored to the students' needs and questions. Only basic demos are used and the topics covered in class are generated by the students in attendance.

The Yaskawa Virtual Training Room is another training option. All you need is an Internet connection and a telephone. This is a live, interactive training class, which gives you the ability to talk to the instructor as well as other students. The Internet connection allows us to show slides and demonstrate software packages. The telephone is for the audio portion of the training class. Web classes can be found on the Yaskawa formal training schedule and can also be done on-demand, per the time and preference of the customer.

Finally, the eLearning Module (eLM™) is a complement to our adjustable frequency drive training seminars. They are modular in nature, pinpoint specific topics, can be completed on or offline, and each one only takes about 30 minutes to complete.

The eLM is a perfect fit for an experienced engineer who needs to understand a specific topic. The eLM does not allow for some typical training practices such as hands-on exercises or student discussions. Students with limited prior experience, and who require a broader and long-term understanding of our products, are advised to take a traditional factory training class.

This list contains available classes at Yaskawa for the J1000 and V1000. If your training need cannot be met by the current training class schedule, please send an email to the Yaskawa Training Coordinator.

Product	eLearning Modules	Factory Classes	List
J1000	eLM.J1000.01	Not Available	N/A
V1000 V1000-4X	eLM.V1000.01	V1000 Installation and Startup Class Number: TRM015-V1000	\$460
		V1000 Application Programming Class Number: TRM010-V1000	\$690

To enroll, contact Technical Training Services.

Terms and Conditions

YASKAWA AMERICA, INC. ("YAI"), DRIVES & MOTION DIVISION - TERMS AND CONDITIONS OF SALE

1. GENERAL:

(a) All sales of products or services by Yaskawa America, Inc., Drives & Motion Division (hereinafter "D&M"), is governed exclusively by these Terms and Conditions of Sale ("Terms"), which supersede all inconsistent or additional terms on Buyer's purchase order or any other document. These Terms constitute the final, complete and exclusive agreement between the parties as to the subject matter hereof. These Terms may be amended only in writing signed by an authorized representative of D&M.

(b) Orders must be submitted in the form of a written purchase order or letter from Buyer, setting forth all information necessary for D&M to fill the Order, if accepted. All proposals, quotations or similar communications from D&M are considered invitations to submit an Order. A binding sales contract will result only when D&M accepts Buyer's Order, at D&M's office in Waukegan, Illinois or such other place as designated by D&M.

2. PRICES:

(a) D&M's quoted prices are firm for thirty (30) days from the date of D&M's written proposal. Thereafter, the applicable prices are those in effect at the time Buyer's Order is placed with D&M. D&M will notify Buyer of any price changes for incorporation into a revised Order prior to acceptance by D&M. Pricing based on volume discounts is subject to adjustment by D&M if actual shipping volumes do not meet minimum volume requirements of agreement. Clerical errors in any element of a proposal, purchase order, invoice or contract are subject to correction by D&M.

3. TERMS OF PAYMENT:

(a) All payments are due within thirty (30) days from date of D&M's invoice. Payment shall be made at the agreed time, to the place specified, and in the currency indicated on D&M's invoice. D&M reserves the right to require payment in advance, or satisfactory security, for any shipment or sale. D&M reserves the right to seek any other remedy available at law or equity and Buyer shall be liable for all expenses, including attorneys' fees, relating to the collection of past due amounts. Buyer's default constitutes a waiver of Buyer's right to demand D&M's performance under the contract.

(b) When an amount becomes past due according to its payment terms, Buyer shall pay interest on the balance due, at the greater of 1.50% per month (18% per annum) or the maximum permitted by law, until paid in full.

(c) If delivery and/or payment in installments is accepted by D&M, Buyer's failure to pay any installment when due shall give D&M the right to suspend work or delivery until such payment is made. In the event that any such default by Buyer continues for more than fifteen (15) days, D&M may then cancel the contract by written notice to Buyer.

(d) All duties, tariffs, fees, costs and other charges connected with shipment, insurance, exportation and importation of the products are the responsibility of Buyer, and, if paid by D&M, such expenses may be recovered by D&M from Buyer, and Buyer shall indemnify D&M against claims for the same. Buyer is responsible for all taxes applicable or related to this transaction, including all sales, use and excise taxes.

4. SECURITY INTEREST:

To secure any indebtedness due and owing from Buyer from time to time, Buyer hereby grants to D&M, and D&M hereby reserves, a continuing purchase money security interest in all Yaskawa-brand and other products heretofore or hereafter sold and delivered to Buyer by D&M, and all related parts, components and accessories therefor, and all proceeds arising from the sale or other disposition of the foregoing, including, but not limited to, cash, accounts, contract rights, accounts receivable, instruments and chattel paper.

Buyer shall at no time grant any security interest that conflicts with that granted to D&M herein. Buyer shall cooperate with D&M, and hereby appoints D&M as its attorney-in-fact, to execute and file, on Buyer's behalf, any documents necessary to evidence and perfect D&M's security interest. D&M reserves all rights and remedies available to it under the Uniform Commercial Code and other applicable law in the event of Buyer's default.

5. SHIPMENT, FORCE MAJEURE, AND ERROR:

(a) Shipment/delivery dates are approximations only. D&M shall not be liable to pay any penalty or damages, including consequential damages, for any delay in shipment.

(b) All shipments are F.O.B. D&M's (or its suppliers') manufacturing plant or warehouse. D&M will, at Buyer's expense, arrange for the transportation of the products from the manufacturing plant or warehouse designated by D&M. All products shall be packaged for domestic shipment in accordance with D&M's standard specifications. If special packaging is required, it must be clearly requested on Buyer's Order. The price for any special packaging shall be billed to Buyer. Buyer is responsible to timely procure all necessary export and import licenses and all permits required for the consummation of the transaction and to obtain insurance coverage on all shipments of products supplied by D&M. Risk of loss and/or damage to the products shall pass to Buyer upon delivery thereof to Buyer or its representative, or to a carrier for shipment to Buyer or its designated customer, as the case may be, at the FOB point.

(c) D&M shall not be liable for any damages, including consequential damages, caused by delays or non-performance resulting from or related to force majeure or other causes beyond D&M's reasonable control, including, but not limited to, war, blockade, civil disturbances, strikes and lockouts, labor shortages, fire and other casualties, acts of nature, accidents and governmental acts (including regulations concerning export and import licensing and currency exchange). In case of non-delivery, D&M's obligation shall be limited to the refund of any advance payment received from Buyer.

(d) All claims for loss of or damage to products, whether concealed or obvious, must be made, in writing, to the carrier and to D&M by Buyer as soon as possible after receipt of shipment, and in no case beyond 30 days of shipment, or such claims shall be deemed waived. D&M will render reasonable assistance in providing information necessary for Buyer to process such damage claims with the carrier or any insurance company.

(e) Buyer agrees to accept delivery within fifteen (15) days following the anticipated date of delivery. If Buyer refuses to take delivery within the fifteen (15) day period, D&M reserves the right to charge Buyer for storage charges plus interest.

6. RETURNS/CANCELLATION CHARGES:

Buyer shall not return products to D&M without the written consent of, and upon terms agreed to, by D&M. If Buyer refuses to accept delivery, or improperly revokes acceptance of product, Buyer shall be responsible for D&M's cancellation charges and expenses. Before any returns, a Return Merchandise Authorization ("R.M.A.") number must be obtained from D&M. Products returned without an R.M.A. number clearly marked on the outside of the shipping carton will be refused. Except for approved warranty returns, D&M will only accept for return and credit new, unused, undamaged, current stock items, in the original packaging. Buyer shall be responsible for all freight charges, import/export charges, duties, tariffs, taxes, insurance and risk of loss/damage regarding return shipment to D&M.

Terms and Conditions

7. DRAWINGS/MEASUREMENTS:

All ratings, drawings, tables, graphs and the like submitted by D&M or set forth in written materials or on the company's website are approximations only. Weights, measurements, capacities and all other particulars of products or services offered by D&M are approximations only. D&M is not responsible for such approximations, including, in particular, based on data supplied by Buyer.

8. LIMITED WARRANTY:

(a) At the time of shipment, new and unused product sold by D&M shall be free from defects in materials and workmanship. D&M warrants that for a period of one (1) year from the date the product is first used by Buyer, or 18 months from the date of shipment, whichever occurs first, if any product or part is found by D&M to be defective, D&M will, at its sole discretion and as Buyer's exclusive remedy, either repair, replace or return the purchase price paid to D&M; provided that the subject product is used under normal conditions for which it was designed and installed, operated and maintained in accordance with D&M's instructions and in accordance with generally accepted industrial practices. Products repaired or replaced during the warranty period shall be covered by the foregoing warranty for the remainder of the original warranty period or ninety (90) days from date of the repair or shipment of the replacement, whichever is longer. D&M warrants, for a period of ninety (90) days, that services shall be performed in a workmanlike manner. Buyer's sole remedy for a breach of this service warranty is limited to further service or a refund or credit of amounts paid by Buyer, at Seller's option.

(b) D&M's warranty obligation shall be conditioned upon receipt by D&M of written notice of any alleged defects within sixty (60) days after discovery. D&M will not be responsible for unauthorized repairs to any products, even if defective. D&M shall not be responsible for any products which have been altered, abused, misused, or improperly installed or repaired, or for any loss, damage, defect, claim or non-performance resulting from or attributable to Buyer's specifications. D&M does not guarantee production rates or the quality of goods made using D&M's products or services, nor shall any longer warranty periods apply, except as agreed in writing signed by an authorized D&M representative.

(c) Where Buyer orders non-stock products or parts manufactured by a third-party, D&M will, to the extent permitted, pass through to Buyer any warranty of the manufacturer. As to such items, Buyer's sole remedy for breach of warranty shall be the remedy offered by and available from the manufacturer, if any.

(d) **D&M'S WARRANTY HEREIN IS IN LIEU OF AND EXCLUDES ALL OTHER WARRANTIES OF D&M AND ANY PARENT OR AFFILIATED COMPANIES OF D&M. D&M DISCLAIMS ALL OTHER WARRANTIES, WHETHER EXPRESS, IMPLIED OR STATUTORY, INCLUDING, BUT NOT LIMITED TO, ANY IMPLIED WARRANTIES OF MERCHANTABILITY AND/OR FITNESS FOR A PARTICULAR PURPOSE OR USE.**

(e) **UNDER NO CIRCUMSTANCES SHALL D&M, OR ANY PARENT OR AFFILIATED COMPANY OF D&M, BE LIABLE TO BUYER OR ANY ENTITY FOR ANY SPECIAL, INDIRECT OR CONSEQUENTIAL DAMAGES, WHETHER ARISING FROM BREACH OF CONTRACT, TORT, NEGLIGENCE, MISREPRESENTATION, STRICT LIABILITY OR OTHERWISE, INCLUDING FOR LOST PROFITS, IMPAIRMENT OF GOODS, WORK STOPPAGE OR OTHERWISE, IN ANY WAY ARISING OUT OF OR RELATED TO PRODUCTS OR SERVICES SUPPLIED BY D&M OR ANY TRANSACTION TO WHICH THESE STANDARD TERMS APPLY. THE MAXIMUM LIABILITY OF D&M, INCLUDING, BUT NOT LIMITED TO, WITH RESPECT TO THE DESIGN, MANUFACTURE, SALE, DELIVERY, RESALE, INSPECTION, ASSEMBLY, INSTALLATION, TESTING, REPAIR, REPLACEMENT, MAINTENANCE OR USE OF ANY PRODUCT OR THE PERFORMANCE OF ANY SERVICE, SHALL NOT EXCEED THE PURCHASE PRICE PAID TO D&M.**

9. INFRINGEMENT:

The liability of D&M, any parent or affiliated company for patent infringement is limited to D&M's defense of proceeding brought against Buyer based on a claim that products, when employed in the manner intended by D&M, constitutes an infringement of any U.S. patent. If Buyer's use of the products in the manner intended by D&M is finally enjoined in such action, D&M shall, at its option, procure for Buyer the right to continue using the products, replace the same with non-infringing products, modify the products so that they become non-infringing equivalent products, or refund the purchase price (less allowance for use, damage or obsolescence). D&M makes no warranty against patent infringement resulting from portions of the products made to Buyer's specifications or the use of products in combination with any other goods or in the practice of any process, and if a claim is brought against D&M or any parent or affiliate of D&M, Buyer shall defend, indemnify and hold D&M (and its parent/affiliates) harmless from and against any and all claims, losses or damages arising therefrom.

10. GOVERNING LAW, FORUM AND JURY WAIVER:

These Terms and the relationship of the parties are governed by the internal laws of the State of Illinois, U.S.A., without regard to its choice of law rules. For all claims or disputes arising out of or relating to the sale of products or services by D&M and/or the relationship of the parties, Buyer shall file any and all lawsuits or claims exclusively in the state or federal courts located in Cook County, Illinois. Buyer hereby submits to the personal jurisdiction of said courts and waives any claim of improper or inconvenient venue. To the fullest extent permitted by law, Buyer hereby agrees to waive the right to trial by jury for all claims or disputes arising out of or relating to the sale of products or services by D&M and/or the relationship of Buyer and D&M. The parties agree that U.N. Convention of Contracts for the International Sale of Goods shall not apply to their relationship or the sale of products by D&M.

11. EXPORT CONTROL:

Buyer acknowledges that the products and related software and technology may be subject to export controls of the U.S. Government, including the Export Administration Regulations of the U.S. Department of Commerce. Buyer shall comply with all applicable laws, regulations, treaties and agreements regarding the use, import, export or re-export of the products and shall be solely responsible for obtaining all required licenses or approvals. The products are not intended for use in any nuclear, chemical or weapons production or environmental damage or for export, re-export, or distribution to any restricted or embargoed country or to a person or entity whose privilege to participate in exports has been denied or restricted by the U.S. Government. Buyer shall indemnify, hold harmless and defend D&M, its parent and affiliated companies from any violation of this section by Buyer or its employees, consultants, agents and customers.

12. MISCELLANEOUS:

(a) Failure on the part of D&M to enforce any of its rights derived from these Terms shall never be construed as a waiver of any of D&M's rights.

(b) The invalidity of one or more of the clauses herein shall not affect the validity of the other clauses, which for this purpose are considered severable.

(c) Any use by Buyer of any YAI trademark must be approved by YAI in writing.

(d) Buyer may not delegate its performance or assign its rights under these Terms except upon the express written consent of D&M. In any case, these Terms shall be binding upon the successors and legal representatives of Buyer.