

MODEL CTS - AC CURRENT OPERATED SWITCH

- UNIVERSAL OUTPUT
- SELF-POWERED
- EASILY ADJUSTABLE SETPOINT
- FIXED OR SPLIT-CORE CASE



GENERAL DESCRIPTION

CTS Series Transducers are self-powered, solid-state current-operated switches that trigger when the current level sensed through the aperture exceeds the adjusted setpoint. The solid state output contacts can switch AC or DC; this "universal" output makes them well suited for application in automation systems.

CTS Series Current Operated Switches combine a current transformer, signal conditioner and limit alarm into a single package for use in status monitoring or proof of operation applications. Offering an extended setpoint range of 1-150 A and universal, solid-state outputs, the self-powered CTS can be tailored to provide accurate and dependable digital indication of over-current conditions across a broad range of applications. Available in solid-core enclosure styles or in a split-core case to maximize ease of installation.

SAFETY SUMMARY

All safety related regulations, local codes and instructions that appear in the literature or on equipment must be observed to ensure personal safety and to prevent damage to either the instrument or equipment connected to it. If equipment is used in a manner not specified by the manufacturer, the protection provided by the equipment may be impaired.

Do not use this unit to directly command motors, valves, or other actuators not equipped with safeguards. To do so, can be potentially harmful to persons or equipment in the event of a fault to the unit.

SPECIFICATIONS

1. **POWER SUPPLY:** None - self powered
2. **OUTPUT:** Magnetically isolated solid-state switch
3. **OUTPUT RATING:** 0.15A, 240 VAC/VDC
4. **OFF STATE LEAKAGE:** <10 μ A
5. **RESPONSE TIME:** 120 msec
6. **HYSTERESIS:** Approx 5% of Setpoint
7. **OVERLOAD:**

MODEL	RANGE	MAXIMUM		
		Continuous	6 sec	1 sec
CTSF	1-150 A	150 A	400 A	1000 A
CTSS	1.5-150 A	150 A	400 A	1000 A
CTSG	1.5 A	250 A	400 A	1000 A

8. **SET POINT RANGES:** Fixed-Core (CTSF): 1-150 A
 Split-Core (CTSS): 1.5-150 A
 Fixed-Core Go/No Go (CTSG): 1.5
9. **SETPOINT ADJUST:** 4 Turn potentiometer (CTSS)
 15 Turn Potentiometer (CTSF)
10. **FREQUENCY RANGE:** 6-100 Hz
11. **ISOLATION VOLTAGE:** UL Listed to 1,270 VAC. Tested to 5,000 VAC
12. **CASE:** UL 94V-0 Flammability rated thermoplastic
13. **ENVIRONMENTAL:** -58 to 149 °F (-50 to 65 °C)
 0-95% RH, non-condensing
14. **TORQUE RATINGS:** 5 in-lbs
15. **LISTING:** UL 508 Industrial Control Equipment, CSA C22.2 No. 14-M95, and CE Certified.

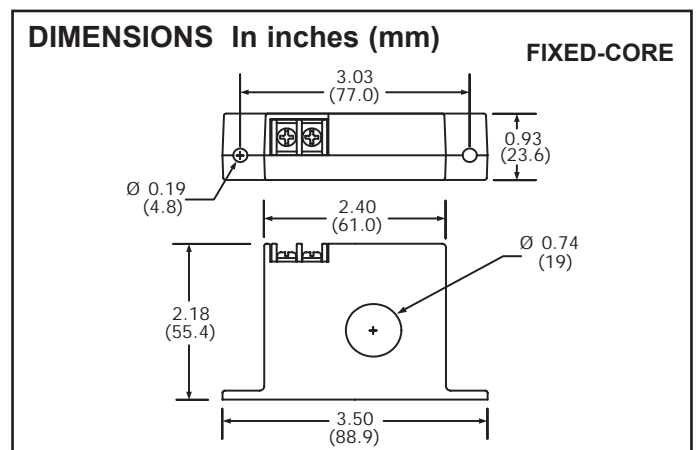
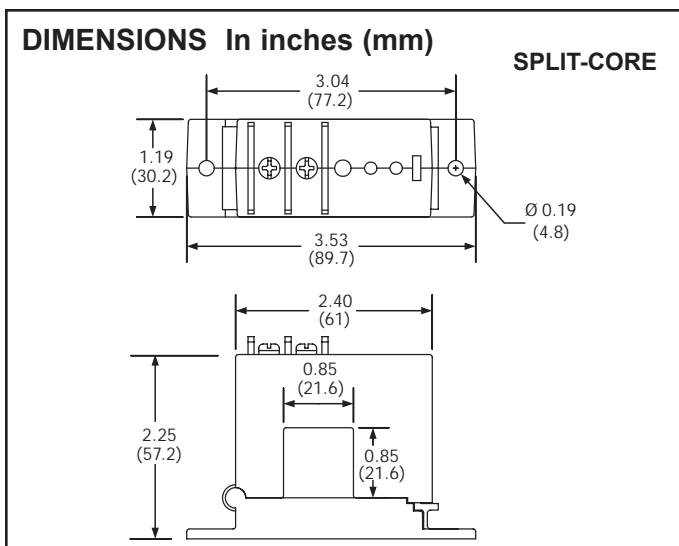
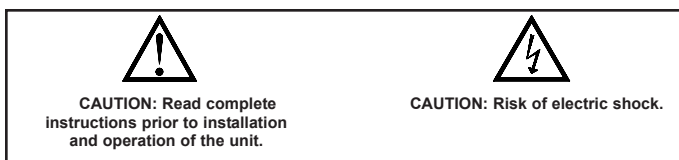

INSTALLATION

Run wire to be monitored through opening in the sensor. The CTS Series transducers work in the same environment as motors, contactors, heaters, pull-boxes, and other electrical enclosures. They can be mounted in any position or hung directly on wires with a wire tie. Just leave at least one inch (25.4 mm) distance between sensor and other magnetic devices.

Split-Core Versions

Press the tab in the direction as shown to open the sensor. After placing the wire in the opening, press the hinged portion firmly downward until a definite click is heard and the tab pops out fully.

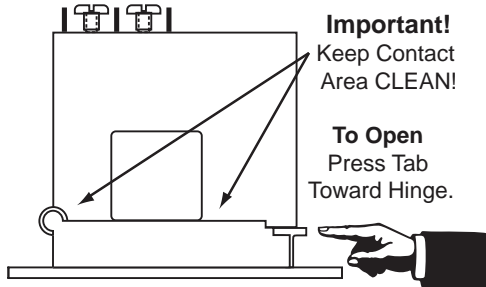

KEEP SPLIT-CORE SENSORS CLEAN.

Silicone grease is factory applied on the mating surfaces to prevent rust and improve performance. Be careful not to allow grit or dirt onto the grease in the contact area. Operation can be impaired if the mating surfaces do not have good contact. Check visually before closing.

OUTPUT WIRING

Connect control or monitoring wires to the sensor. Use up to 14 AWG copper wire and tighten terminals to 5 inch-pounds torque. Be sure the output load does not exceed the switch rating.

CAUTION: Incandescent lamps can have “Cold Filament Inrush” current of up to 10 times their rated amperage. Use caution when switching lamps.

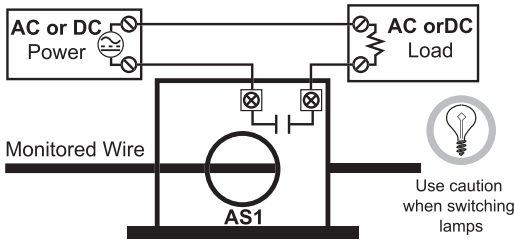

SETPOINT ADJUSTMENT

CTS Series SETPOINT is adjusted with a 4-turn potentiometer (CTSS) or a 15-turn potentiometer (CTSf). The pot is shipped factory set to the lowest setpoint, fully clockwise (CW). Turning the pot counter-clockwise (CCW) will increase the setpoint. The pot has a slip-clutch to prevent damage at either end of its rotation. To determine where the adjustment is, turn the pot all the way CW. This will return it to the minimum setpoint.

Adjustment Notes:

1. Output contacts are solid-state. Check output status by applying voltage to the contacts and reading the voltage drop across the contacts. An Ohmmeter set on “Continuity” will give misleading results.
2. It is recommended that the setpoint be adjusted to allow for voltage variations of 10-15%.

Typical Adjustment

1. Turn the pot to minimum setpoint (4 or 15 turns CW).
2. Have normal operating current running through the sensor. The output should be tripped since the pot is at its minimum setpoint. For units with LED, it should be flashing fast (2 to 3 times per second).
3. Turn the pot CCW until the unit un-trips. This is indicated by the slow flashing of the LED (once every 2 to 3 seconds), or by the changing of the output switch status.
4. Now turn the pot CW slowly until the unit trips again. It is now set at the current level being monitored.
 - A. To Set UNDERLOAD - Turn the pot about 1/8 turn further CW.
 - B. To Set OVERLOAD - Turn the pot about 1/8 turn further CCW.

MONITORED AMPS	OUTPUT	SMART-LED
None or <Min.	OPEN	OFF
Below Trip Level	OPEN	SLOW (2 sec)
Above Trip Level	CLOSED	FAST (0.5 sec)

TROUBLE SHOOTING

1. Sensor Is Always Tripped

- A. The setpoint may be too low. Turn pot CCW to increase setpoint.
- B. Switch has been overloaded and contacts are burned out. Check the output load, remembering to include inrush on inductive loads (coils, motors, ballasts).

2. Sensor Will Not Trip

- A. The setpoint may be too high. Turn pot CW to decrease setpoint.
- B. Split Core models: The core contact area may be dirty. Open the sensor and clean the contact area.
- C. Monitored current is below minimum required. Loop the monitored wire several times through the aperture until the “sensed” current rises above minimum. Sensed Amps = (Actual Amps) x (Number of Loops). Count loops on the inside of the aperture.
- D. Switch has been overloaded and contacts are burned out. Check the output load, remembering to include inrush on inductive loads (coils, motors, ballasts).

ORDERING INFORMATION

MODEL NO.	DESCRIPTION	PART NUMBERS
CTS	1.5-150 A Split-Core Current Switch	CTSS0000
	1-150 A Fixed-Core Current Switch	CTSF0000
	1.5 A Fixed-Core Go-No Go Current Switch	CTSG0000

LIMITED WARRANTY

The Company warrants the products it manufactures against defects in materials and workmanship for a period limited to two years from the date of shipment, provided the products have been stored, handled, installed, and used under proper conditions. The Company's liability under this limited warranty shall extend only to the repair or replacement of a defective product, at The Company's option. The Company disclaims all liability for any affirmation, promise or representation with respect to the products.

The customer agrees to hold Red Lion Controls harmless from, defend, and indemnify RLC against damages, claims, and expenses arising out of subsequent sales of RLC products or products containing components manufactured by RLC and based upon personal injuries, deaths, property damage, lost profits, and other matters which Buyer, its employees, or sub-contractors are or may be to any extent liable, including without limitation penalties imposed by the Consumer Product Safety Act (P.L. 92-573) and liability imposed upon any person pursuant to the Magnuson-Moss Warranty Act (P.L. 93-637), as now in effect or as amended hereafter.

No warranties expressed or implied are created with respect to The Company's products except those expressly contained herein. The Customer acknowledges the disclaimers and limitations contained herein and relies on no other warranties or affirmations.